



PUBLIC WORKS
Engineering

DATE: May 8, 2026

TO: PAUL ZACHARY,
PUBLIC WORKS DEPUTY
DIRECTOR

FROM: H. SOMDECERFF,
PUBLIC WORKS DESIGN
MANAGER

HAS

The Specification Review Committee recommends and asks the Public Works Deputy Director to approve the following:

1. Approve Modification to Standard Detail 409A - Concrete Manhole Collar for Concrete Roads. Summary of change: The original Standard Detail 409 was divided into two Standard Details (409A & 409B) to clarify the different manhole collar shapes and their use in specific road types. The square manhole collar 409A is to be used for Concrete Road types.

Please call LaNay Cosby at (918) 596-9565 if you have any questions.

Thank you,

APPROVED:

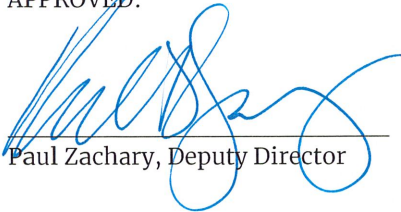
 Paul Zachary, Deputy Director



 Date

1836 * 1898

TUL * USA

Cc: Public Works Engineering Services Specification Review Committee

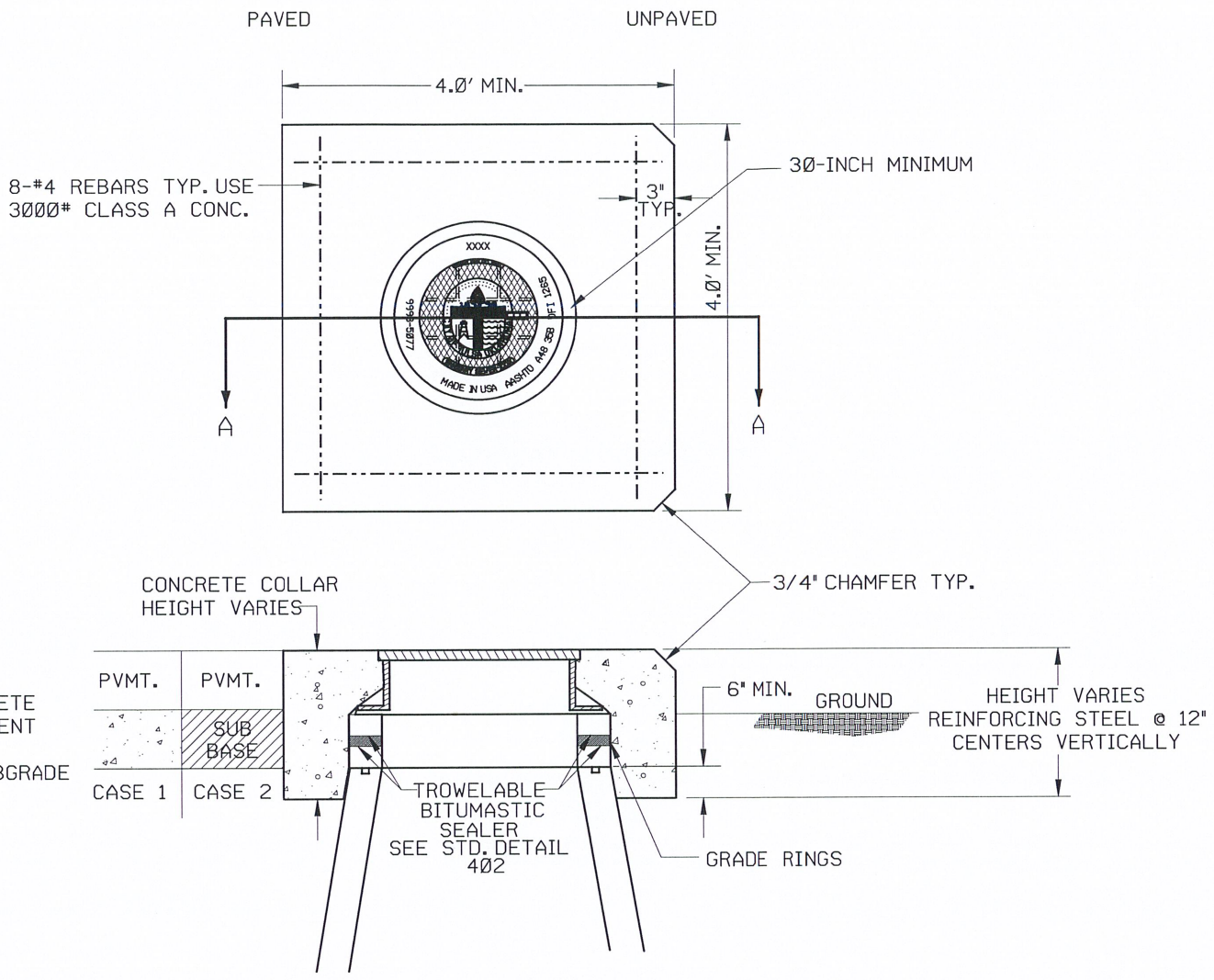
PATH NAME: /E1/PARTS/STD/DGN.STDS/409A-CONC-MH-COLLAR.DGN DJN 04/30/2026



SECTION A-A

CASE 1
 COLLAR SHALL EXTEND TO TOP OF CONCRETE (REBAR REQ.)

CASE 2
 COLLAR SHALL EXTEND 3" BELOW BOTTOM OF LOWEST GRADE RING (REBAR REQ.)

CONCRETE MANHOLE COLLAR DETAIL
RECTANGULAR
 NOT TO SCALE

NOTES: CONCRETE MANHOLE COLLARS ARE REQUIRED FOR ALL NEW AND REHABILITATED MANHOLES LOCATED IN THE PAVED AREAS AND SHALL BE BROUGHT TO FINISH GRADE WITH CONCRETE. COLLARS SHALL NOT BE USED IN UNPAVED AREAS OR FOR RAISED MANHOLES. REFER TO SPECIFICATIONS 416.3.12 FOR MORE DETAILS AND PAYMENT INFORMATION.

CONCRETE MANHOLE COLLAR FOR CONCRETE ROADS	
CITY OF TULSA, OKLAHOMA	
DRAWN BY: D.J.N. CHECKED BY: <i>tjp</i> DATE: MAY 2026	APPROVED <i>TJOK</i>
NOT TO SCALE	STANDARD NO. 409A