

PUBLIC WORKS
Engineering

DATE: May 8, 2026

TO: PAUL ZACHARY,
PUBLIC WORKS DEPUTY
DIRECTOR

FROM: H. SOMDECERFF,
PUBLIC WORKS DESIGN
MANAGER

HAS

The Specification Review Committee recommends and asks the Public Works Deputy Director to approve the following:

1. Approve Modification to Standard Detail 307 - Bore/Open Cut Conduit Detail.
Summary of change: The steel conduit dimension called out was changed from 3/8-inch minimum to 1/2-inch minimum. The word SERIES was spelled out completely under the EPOXY PAINT callout. An asterix was removed from the 24-inch dimension on the callout pointing to the concrete collar.

Please call LaNay Cosby at (918) 596-9565 if you have any questions.

Thank you,

APPROVED:

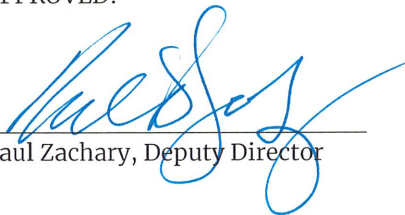

 Paul Zachary, Deputy Director

05-19-26

 Date

Cc: Public Works Engineering Services Specification Review Committee

1836 * 1898

TUL * USA

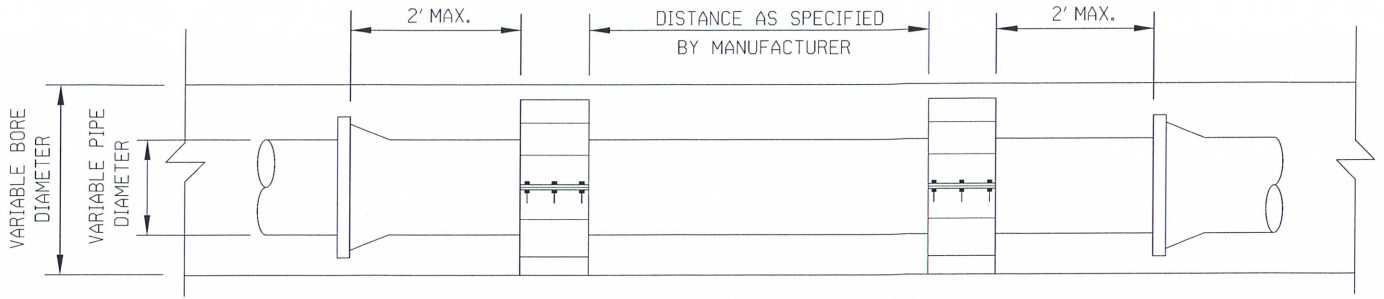

TYPICAL BORE WITH PIPE INSTALLED

LONGITUDINAL VIEW
NOT TO SCALE

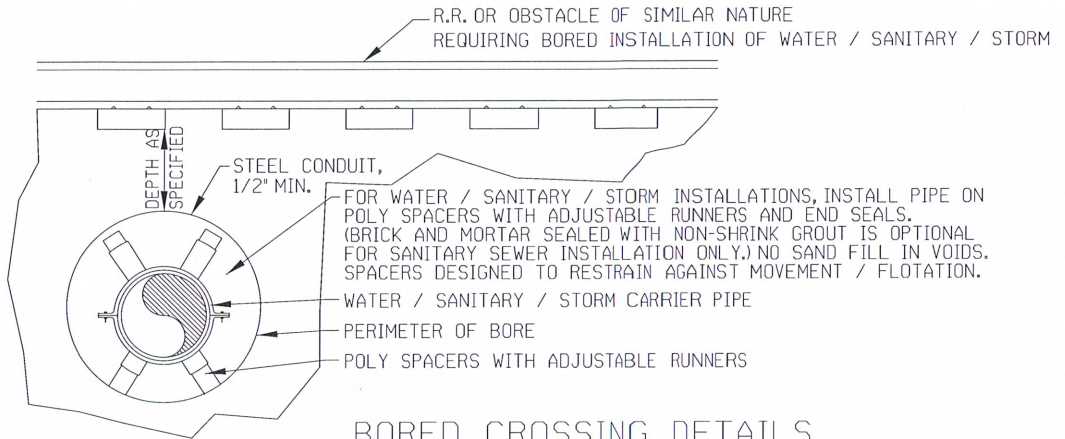

BORED CROSSING DETAILS

NOT TO SCALE

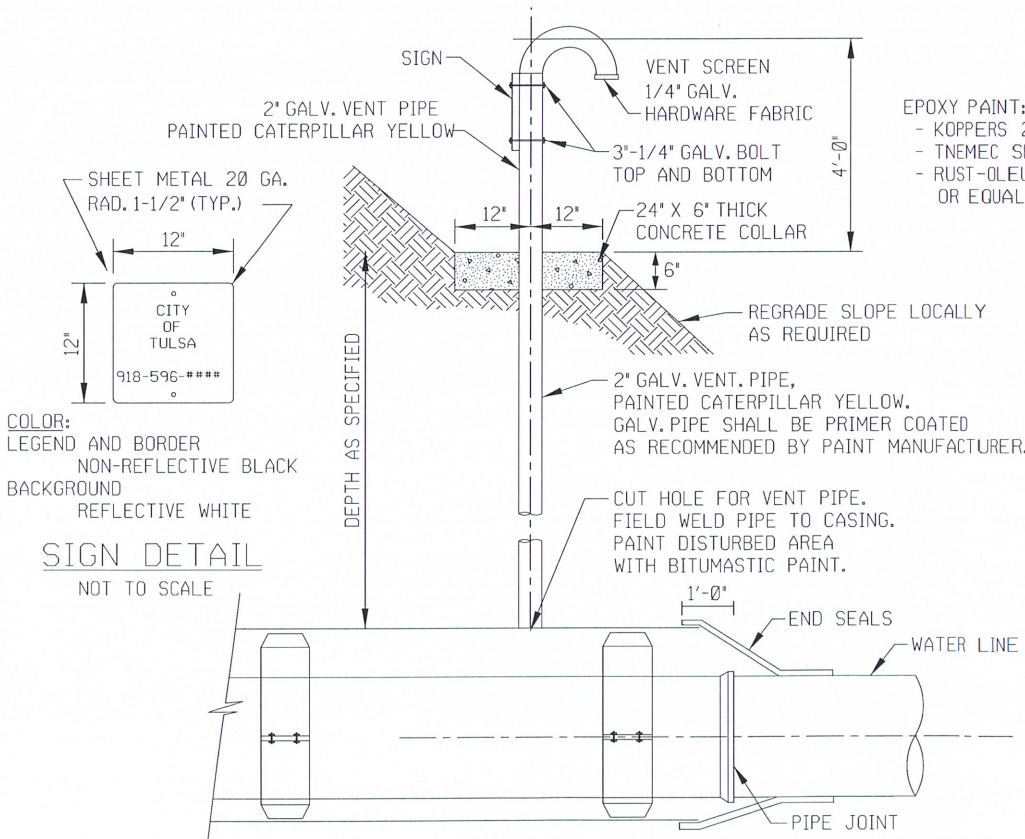

- EPOXY PAINT:**
- KOPPERS 200
 - TNEMEC SERIES 66 EPOXOLINE
 - RUST-OLEUM 9100 HIGH PERFORMANCE EPOXY, OR EQUAL

COLOR:
LEGEND AND BORDER
NON-REFLECTIVE BLACK
BACKGROUND
REFLECTIVE WHITE

SIGN DETAIL

NOT TO SCALE

ALTERNATE VENT PIPES AT CONDUIT ENDS

NOT TO SCALE

BORE/OPEN CUT CONDUIT DETAIL	
CITY OF TULSA, OKLAHOMA ENGINEERING SERVICES DEPARTMENT	
DRAWN BY: D.J.N.	APPROVED
CHECKED BY:	
DATE: MAY 2026	
NOT TO SCALE	STANDARD NO. 307