

PATH NAME: /E1/PARTS/STD/DGN.STDS/409A-CONC-MH-COLLAR.DGN DJN 04/30/2026

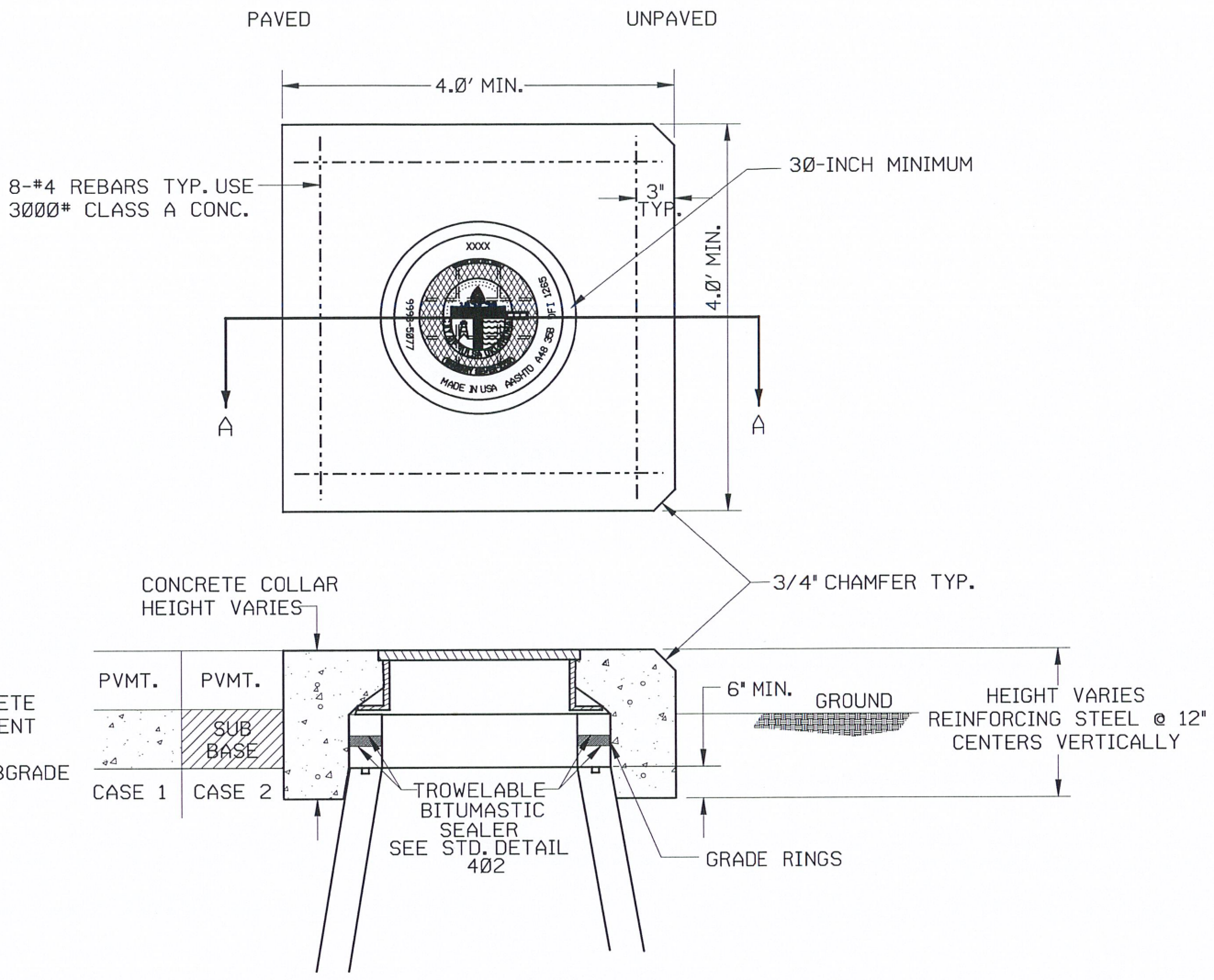

SECTION A-A

CASE 1
 COLLAR SHALL EXTEND TO TOP OF CONCRETE (REBAR REQ.)

CASE 2
 COLLAR SHALL EXTEND 3" BELOW BOTTOM OF LOWEST GRADE RING (REBAR REQ.)

CONCRETE MANHOLE COLLAR DETAIL
RECTANGULAR
 NOT TO SCALE

NOTES: CONCRETE MANHOLE COLLARS ARE REQUIRED FOR ALL NEW AND REHABILITATED MANHOLES LOCATED IN THE PAVED AREAS AND SHALL BE BROUGHT TO FINISH GRADE WITH CONCRETE. COLLARS SHALL NOT BE USED IN UNPAVED AREAS OR FOR RAISED MANHOLES. REFER TO SPECIFICATIONS 416.3.12 FOR MORE DETAILS AND PAYMENT INFORMATION.

CONCRETE MANHOLE COLLAR FOR CONCRETE ROADS	
CITY OF TULSA, OKLAHOMA	
DRAWN BY: D.J.N. CHECKED BY: <i>tjp</i> DATE: MAY 2026	APPROVED <i>TJOK</i>
NOT TO SCALE	STANDARD NO. 409A