

**CONTRACT DOCUMENTS
AND
SPECIFICATIONS
FOR
PROJECT NO. TMUA ES-2025-SOM5
SANITARY SEWER REHAB & REPAIRS**

ATTENDANCE AT PRE-BID CONFERENCE IS MANDATORY



WATER AND SEWER

Eric Lee, Director

Sewer Operations & Maintenance
9319 E 42nd St N
Tulsa, Oklahoma 74115
(918) 586-6952

CONTRACT DOCUMENTS

TULSA METROPOLITAN UTILITY AUTHORITY PROJECT NO. TMUA ES-2025-SOM5 SANITARY SEWER REHAB & REPAIRS

<u>INDEX TO BIDDING DOCUMENTS</u>	<u>PAGE</u>
NOTICE TO BIDDERS	NB-1-2
INSTRUCTIONS TO BIDDERS	IB-1-6
RESOLUTION 18145, PROVIDING FOR THE EMPLOYMENT OF RESIDENTS OF THE METROPLITAN STATISTICAL AREA	R-1-3
RESOLUTION NO. 7404	RAC-1
AFFIDAVIT FOR 50% RESIDENT RESOLUTION	RRA-1
NONCOLLUSION AFFIDAVIT	NA-1
INTEREST AFFIDAVIT	IA-1
BUSINESS RELATIONSHIP AFFIDAVIT	BR-1
PROPOSAL	P-1-3
CERTIFICATE OF SECRETARY	CS-1
CONSENT OF MEMBERS	CM-1
SALES TAX EXEMPTION DOCUMENT	STED-1
EXTENSION OF TIME REQUEST	ETR-1
CONTRACT	C-1-4
PERFORMANCE BOND	PB-1-2
STATUTORY BOND	SB-1-2
MAINTENANCE BOND	MB-1-2
AFFIDAVIT FOR CONTRACT/CLAIM	AC-1
GENERAL CONDITIONS	TMUAGC-1-20
<u>SPECIAL PROVISIONS</u>	
SUPPLEMENTAL CONTRACT REQUIREMENTS	SCR-1-3
<u>PLAN SHEETS</u>	
REHAB SCHEDULE	RS- 1
MANHOLE REHAB SCHEDULE	MHRS-1
PIPE REHAB SCHEDULE	PRS-1
PLANSHEET	1-13
<u>STANDARD SPEC DRAWINGS</u>	
COMPOSITE COVER	
FRAME & COVER FOR FLOOD PLAIN	NO. 359
STANDARD ELEVATED MANHOLE	NO. 368
STANDARD ELEVATED FRP MANHOLE	NO. 369
HYDRAULIC SLIDE MANHOLE	NO. 370
STANDARD DETAIL DROP	NO. 416
DROP DETAIL SLIPLINE 8-INCH	NO. 417
DROP DETAIL SLIPLINE 10-INCH	NO. 418
MANHOLE OUTSIDE DROP CONNECTION	NO. 419
<u>FORMS</u>	
CONTRACTOR WORK ORDER/SERVICE RECONNECTION FORM	
BY-PASS PUMPING NOTIFICATION FORM	

Published in the Tulsa World:
January 31, February 3, 4, 5, 6, 7, 2025

**NOTICE TO BIDDERS
SEALED BIDS FOR
TULSA METROPOLITAN UTILITY AUTHORITY
PROJECT NO. TMUA ES-2025-SOM5**

Notice is hereby given that pursuant to an order by the Tulsa Metropolitan Utility Authority, a Public Trust, sealed bids will be received in Room 260 of the Office of the City Clerk, City of Tulsa, 175 E. 2nd Street, Tulsa, OK 74103 **until 8:30 a.m., on the 14th day of March, 2025**, for furnishing all tools, materials and labor and performing the work necessary to be done in the construction of the following:

**PROJECT NO. TMUA ES-2025-SOM5
SANITARY SEWER REHAB & REPAIRS**

The cost of the improvement shall be paid primarily from Account No. 7503352-531702

A **MANDATORY** Pre-Bid Conference is scheduled for **Tuesday, February 18, 2025, at 10:30 a.m.** by joining Teams Meeting online from your computer, tablet, or smart phone Meeting ID: 221 039 546 077 Passcode: wF99Nm7j. For more information concerning the proposed work, contact Chris Kovac at (918) 586-6952.

Attendance at the Pre-Bid Conference is MANDATORY. Bids will not be received from contractors who did not attend the Pre-Bid Conference.

Bids will be accepted by the City Clerk from the holder of valid pre-qualification certificates from the City of Tulsa in one or more of the following classifications: **A or D.**

Contract documents for the construction of said public improvements of the said project have been adopted by the Tulsa Metropolitan Utility Authority of said City. Copies of same may be obtained at Contract Administration Office 2nd floor, 175 E 2nd St Tulsa, Oklahoma, for a non-refundable fee in the amount of **\$50.00** made payable to the Tulsa Metropolitan Utility Authority by check or money order.

Contract requirements shall include compliance as required by law pertaining to the practice of non-discrimination in employment.

Attention is called to Resolution No. 18145 of August 23, 1988, requiring bidders to commit to the goal of employing on the project at least fifty percent bona fide residents of the City of Tulsa and/or MSA in each employment classification.

The Authority, acting on behalf of the City of Tulsa, is exempt from the payment of any sales or use taxes, and pursuant to Title 68 O.S. Section 1356(10), direct vendors to the Authority are also exempt from those taxes. A bidder may exclude from his bid appropriate sales taxes which he will not have to pay while acting for and on behalf of the Tulsa Metropolitan Utility Authority. See Contract Article IIB.

A Certified or Cashier's Check or Bidder's Surety Bond, in the sum of 5% of the amount of the bid will be required from each bidder to be retained as liquidated damages in the event the successful bidder fails, neglects or refuses to enter into said contract for the construction of said public improvements for said project and furnish the necessary bonds within thirty days from and after the date the award is made.

The bidder to whom a contract is awarded will be required to furnish public liability and workmen's compensation insurance, performance, statutory, and maintenance bonds acceptable to the Authority, in conformity with the requirements of the proposed contract documents. The performance, statutory, and maintenance bonds shall be for one hundred percent (100%) of the contract price.

All bids that have been duly received will be publicly opened and considered by the Bid Committee of said City at a meeting of said Committee to be held in the City Council Room of City Hall in said City at **9:00 a.m.** on the **14th** day of **March, 2025.**

Dated at Tulsa, Oklahoma, this 31ST day of January, 2025.

Rick Hudson, Chairman
Tulsa Metropolitan Utility Authority

INSTRUCTIONS TO BIDDERS

B-1. BIDS

Each bid Proposal shall be completed, signed, and submitted. No alterations, additions, or erasures shall be made on the Proposal. Erroneous entries shall be lined out, initialed by the bidder, and the correct entry inserted. The unit price bid must cover all expense for furnishing the labor, materials, tools, equipment, and apparatus of every description to construct, erect, and furnish all work required by and in conformance with the Drawings and Specifications.

Each bid shall be enclosed in a sealed envelope addressed to the Tulsa Metropolitan Utility Authority, 175 E. 2nd Street, Room 260, City Hall, Tulsa, Oklahoma, identified on the outside with the words:

PROJECT NO. TMUA ES-2025-SOM5 SANITARY SEWER REHAB & REPAIRS

Pre-qualification Certificate Number _____.

And shall be filed with the City Clerk in Room 260, City Hall.

All addenda to the contract documents should be denoted on the last page of the Proposal in the space provided.

B-2. BID SECURITY

Each bid shall be accompanied by a cashier's check, a certified check, or bidder's bond, in the amount of five percent (5%) of the total amount bid.

The bid security shall be made payable, without condition, to the Tulsa Metropolitan Utility Authority, Oklahoma. The bid security may be retained by and shall be forfeited to the Authority as liquidated damages if the bid is accepted, a contract based thereon is awarded, and the bidder fails to enter into a contract in the form prescribed, with legally responsible sureties, within thirty (30) days after such award is made by the Authority.

B-3 RETURN OF BID SECURITY

The bid security of each unsuccessful bidder will be returned when his bid is rejected. The bid security of the bidder to whom the contract is awarded will be returned when he executes a contract and files satisfactory bonds. The bid security of the second lowest responsible bidder may be retained for a period of time not to exceed sixty (60) days pending the execution of the contract and bonds by the successful bidder.

B-4 WITHDRAWAL OF BIDS

No bidder may withdraw his bid for sixty (60) days after the date and hour set for the opening. A bidder may withdraw his bid any time prior to expiration of the period during which bids may be submitted by making a written request signed in the same manner and by the same person who signed the Proposal.

B-5 REJECTION OF BIDS

Bids received more than ninety-six (96) hours before the time set for opening bids, excluding Saturdays, Sundays, and holidays, as well as bids received after the time set for opening bids, will not be considered and will be returned unopened.

The Tulsa Metropolitan Utility Authority reserves the right to reject any and all bids when such rejection is in the best interest of the Tulsa Metropolitan Utility Authority. All bids are received subject to this stipulation and the Authority reserves the right to decide which bidder shall be deemed lowest responsible bidder.

A violation of any of the following provisions by a bidder shall be sufficient reason for rejecting bidder's bid, or shall make any contract between the Tulsa Metropolitan Utility Authority and the Contractor that is based on bidder's bid, null and void: divulging the information in said bid before the bids have been opened; submission of a bid which is incomplete, unbalanced, obscure, incorrect, or which has conditional clauses, additions, or irregularities of any kind not in the original proposal form, or which is not in compliance with the Instruction to Bidders and published Notice to Bidders, or which is made in collusion with another bidder. The Authority shall have the right to waive any immaterial defects or irregularities in any bid received.

B-6 DISQUALIFICATION OF BIDDERS

No contract will be awarded to any person or persons, firm, partnership, company, or corporation which is in arrears to the Authority upon any debt of contract, or in default as surety or otherwise upon any obligation to the Authority.

B-7 SIGNATURE OF BIDDERS

Each bid shall be properly signed with the full name of the company or individual submitting the bid, the bidder's address, and the name and title of all persons signing printed below their signature lines. Bids by partnerships shall be signed with the partnership name followed by the signature and title of one of the partners. Bids by corporations shall be signed with the name of the corporation followed by the signature and title of the president, vice president, chairman, or vice chairman of the Board of Directors with attestation by the corporate secretary or assistant corporate secretary. Bids by joint ventures shall be signed by each participant in the joint venture. Bids by limited liability companies shall be signed with the name of the limited liability company followed by the signature and title of the Manager or Managing Member. Bid by limited partnerships shall

be signed with the name of the limited partnership followed by the signature of the general partner. Note: The signature requirements listed above are for Oklahoma entities; entities organized in other states must follow the law of the state in which they are organized.

A bid by a person who affixes to his signature the word "President", "Manager", "General Partner", "Agent", or other title, without disclosing the name of the company for which he is signing, may be held to be the bid of the individual signing.

B-8 INTERPRETATION OF CONTRACT DOCUMENTS

If any bidder who contemplates submitting a bid is in doubt as to the true meaning of any part of the drawing, specifications, or other proposed contract documents, bidder may submit to Contract Administration and the Engineer a written request for interpretation thereof. The person submitting the request shall be responsible for its prompt delivery. Interpretation of the proposed contract documents will be made only by addendum. The addendum will be posted on the Tulsa Metropolitan Utility Authority website and emailed to all the pre-bid attendees. The Authority will not be responsible for any other explanations or interpretations of the proposed contract documents.

B-9 LOCAL CONDITIONS AFFECTING WORK

Each bidder shall visit the site of the work and shall completely inform himself relative to construction hazards and procedure, labor, and all other conditions and factors, local and otherwise, which would affect prosecution and completion of the work and its cost. Such considerations shall include the arrangement and condition of existing structures and facilities, the procedure necessary for maintenance of uninterrupted operation of existing structures and facilities, the availability and cost for labor, and facilities for transportation, handling, and storage of materials and equipment. All such factors shall be properly investigated and considered in the preparation of the bid. There will be no subsequent financial adjustment for lack of such prior information.

B-10 TIME OF COMPLETION

The time of completion is an essential part of the contract and it will be necessary for each bidder to satisfy the Authority of his ability to complete the work within the allowable time set forth in the Bid Form. In this connection, attention is directed to the provisions of the General Conditions and Special Conditions relative to delays, extension of time, and liquidated damages.

B-11 QUALIFICATION OF BIDDERS

No bid will be received and filed by the City Clerk of the Tulsa Metropolitan Utility Authority unless the person submitting the bid has been pre-qualified as provided by ordinance, and is the holder of a current certificate of Pre-qualification in force and effect on the date such bid is to be submitted and filed.

B-12 TAXES AND PERMITS

Attention is directed to the requirements of the General Conditions regarding payment of taxes and obtaining permits. Contractor shall comply with all zoning ordinances of the City, as provided in the Tulsa Zoning Code, Title 42 Tulsa Revised Ordinances and conform with all zoning requirements established by the Tulsa Metropolitan Area Planning Commission and the Board of Adjustment. Contractor can call the Indian Nations Council of Governments (INCOG) at (918) 584-7526, to determine if any zoning requirements must be met.

B-13 OKLAHOMA LEGAL REQUIREMENTS

The Contractor must comply with the Oklahoma Scaffolding Law, 40 Oklahoma Statutes, Sections 174 - 177, which cover erection and use of scaffolds, hoists, cranes, stays, ladders, supports, or other mechanical contrivances.

In accordance with Oklahoma Statutes, Title 68, Section 1701-1707, before commencing any work pursuant to this contract, any nonresident contractor shall give written notice by certified mail, return receipt requested, to the Oklahoma Tax Commission, the Oklahoma Employment Security Commission, the Workers Compensation Court, and the county assessor of each county in which work will be performed. The notices shall comply with the requirements set forth in said statute.

B-14 BONDS

The bidder to whom a contract is awarded will be required to furnish bonds as follows:

- a. Performance Bond – A Performance Bond to the Authority in an amount equal to one hundred percent (100%) of the Contract price.
- b. Statutory Bond – A Statutory Bond to the State of Oklahoma in an amount equal to one hundred percent (100%) of the contract price.
- c. Maintenance Bond – A Maintenance Bond to the Authority in an amount equal to one hundred percent (100%) of the contract price.

The bonds shall be executed on the forms included in the contract documents by a surety company authorized to do business in the State of Oklahoma and acceptable as Surety to the Tulsa Metropolitan Utility Authority.

Accompanying the bonds shall be a "Power-of-Attorney" authorizing the attorney-in-fact to bind the Surety Company and certified to include the dates of the bonds.

B-15 BOUND COPY OF CONTRACT DOCUMENTS

Bound contract documents are no longer required.

B-16 EQUAL EMPLOYMENT OPPORTUNITY REQUIREMENTS

Each bidder agrees to comply with the terms of Title 5, Chapter 1, Section 111, of the Tulsa Revised Ordinances relating to Non-Discrimination.

B-17 BASIS FOR AWARD OF CONTRACT

The basis for award of a contract shall be the total base bid submitted by the lowest responsible bidder unless otherwise directed in the form of proposal. The Tulsa Metropolitan Utility Authority reserves the right to withhold the awarding of a contract for a reasonable period of time from the date of opening of bids. The awarding of a contract upon a successful bid shall give the bidder no right or action or claim against the Tulsa Metropolitan Utility Authority upon such contract until the same shall have been reduced to writing and duly signed by the contracting parties. The award of a contract will not be completed until the contract is duly executed and the necessary bonds and insurance approved.

B-18 TIME FOR AWARDING OF CONTRACT

The awarding of a contract to the lowest responsible bidder will be made within thirty (30) days after the opening of bids unless the Tulsa Metropolitan Utility Authority by formal recorded action and for good cause shown, provides for a reasonable extension to that period, which extension period shall not in any event exceed fifteen (15) days where only state or local funds are involved, or not to exceed ninety (90) days on any award of contract for the construction of public improvements where funds are utilized which are furnished by an agency of the federal government.

B-19 SAFETY AND HEALTH REGULATIONS

Bidders should note that they are subject to "Safety and Health Regulations for Construction", Chapter XVII of Title 29, CFR, Part 1926 and that compliance, review and enforcement are the responsibility of the U.S. Department of Labor.

The Contractor is fully responsible for the safety of the work site and is expected to train their employees in all applicable safety issues. This should include but not be limited to: trench safety, confined space entry, head protection, etc. In accordance with construction contracts with the City, Authority, Board, or Commission, all applicable Labor and OSHA safety regulations must be followed.

Work sites must be monitored by the Contractor and safety provisions enforced. Contractors are asked to ensure that all employees are properly informed and trained in construction, work site safety.

B-20 VENDORS AND SUBCONTRACTOR IDENTIFICATION

Where Vendor and Subcontractor Identification Questionnaires are included in the bid documents, each bidder shall submit the Questionnaire directly to the Engineer no later than 5:00 p.m. on the first working day following the bid

11.15.24

opening. Failure to submit the questionnaire may render the bid unresponsive and not eligible for award. The award of the Contract will be subject to the acceptability of the vendors and subcontractors listed. If an award is made, the vendors and subcontractors listed on the questionnaire shall be used on the project. No changes in the vendor and subcontractor list will be permitted unless prior consent is obtained from the Engineer.

B-21 U.S. ENVIRONMENTAL PROTECTION AGENCY NPDES REQUIREMENTS FOR STORMWATER DISCHARGES

The bidder's attention is directed to U.S. Environmental Protection Agency (EPA) NPDES requirements for stormwater discharges. The Contractor shall be responsible for filing a Notice of Intent and development and implementation of a Stormwater Pollution Prevention Plan (PPP).

B-22 AMERICANS WITH DISABILITIES ACT

The Contractor shall take the necessary actions to ensure its facilities are in compliance with the requirements of the Americans with Disabilities Act (ADA). It is understood that the program of the Contractor is not a program or activity of the Tulsa Metropolitan Utility Authority. The Contractor agrees that its program or activity will comply with the requirements of the ADA. Any costs of such compliance will be the responsibility of the Contractor. Under no circumstances will the Contractor conduct any activity, which it deems non-compliant with the ADA.

RESOLUTION NO. 18145

A RESOLUTION REQUIRING THE INCLUSION IN PLANS AND SPECIFICATIONS FOR PUBLIC IMPROVEMENT CONTRACTS OF PROVISIONS PROVIDING FOR THE EMPLOYMENT OF BONA FIDE RESIDENTS OF THE CITY OF TULSA; AND/OR THE MSA; ALSO PROVIDING THAT AT LEAST OF FIFTY PERCENT (50%) OF EACH CLASS OF EMPLOYEES USED ON A PROJECT BE BONA FIDE RESIDENTS OF THE CITY OF TULSA AND/OR THE MSA; THAT THE DIRECTOR OF THE DEPARTMENT OF HUMAN RIGHTS IS CHARGED WITH ENSURING THAT ALL BIDS FOR PUBLIC CONSTRUCTION CONTRACTS COMPLY WITH THIS RESOLUTION; AND DECLARING AN EMERGENCY.

WHEREAS, City of Tulsa, Oklahoma, desires to achieve a goal of full employment.

WHEREAS, it is necessary for the protection of the health, safety and welfare of all residents of the City of Tulsa, Oklahoma, to accomplish this goal.

NOW, THEREFORE, BE IT RESOLVED BY THE BOARD OF COMMISSIONERS OF THE CITY OF TULSA, OKLAHOMA:

SECTION 1. The City of Tulsa is committed to the policy of achieving full employment of its citizens by encouraging the employment of bona fide Tulsa and MSA residents in public improvement contracts.

SECTION 2. Definitions. The definitions of certain terms used in this resolution are as follows:

a. "Bidding Documents" or "Bid" means the bid notice, plans and specifications, bidding form, bidding instructions, special provisions and all other written instruments prepared by or on behalf of an awarding public agency for use by prospective bidders on a public construction contract.

b. (i) "Bona Fide Residents" shall include only those persons who are either registered to vote in the City of Tulsa or who have resided within the city limits for at least six months, or who have purchased a permanent residence within the city limits or who have leased a residence for at least a six month term. Residency may be further determined by a valid Oklahoma driver's license, a current Oklahoma license tag, and a valid Oklahoma automobile inspection sticker. (ii) Bona fide residents of MSA shall include only those persons who are registered to vote in outlying MSA areas or who have resided within the outlying MSA area for at least six months, or who have purchased a permanent residence within the outlying MSA areas or who have leased a residence for at least a six month term. Residency may be further determined by a valid Oklahoma driver's license, a current Oklahoma license tag, and a valid Oklahoma automobile inspection sticker.

c. "Public Construction Contract" or "Contract" means any contract exceeding Seven Thousand Five Hundred Dollars (\$7,500.00) in amount, awarded by the City of Tulsa for the purpose of making any public improvements or constructing any public building or making repairs to the same.

d. "Public Improvement" means any beneficial or valuable change or addition, betterment, enhancement or amelioration of or upon any real property, or interest therein, belonging to the City of Tulsa, intended to enhance its value, beauty or utility or to adapt it to new or further purposes. The term does not include the direct purchase of materials, equipment or supplies by the City of Tulsa.

CITY OF TULSA
FILED

AUG 23 1988

Office Of City Auditor

e. "MSA". All of the land areas composed of Creek County, Osage County, Rogers County, Tulsa County and Wagoner County.

SECTION 3. Residency Requirements of Contractor's Employees. Every employee and/or agent of the City of Tulsa, Oklahoma, charged or involved with the preparation of plans and specifications for any public improvement funded in whole or in part with funds of the City of Tulsa, is hereby charged to include in said plans and specifications the following provisions which shall be binding upon the successful bidders:

- a. Each bid shall be accompanied by a sworn statement that the bidder is committed to the goal of employing at least 50% bona fide residents of the City of Tulsa and/or the MSA in each classification as determined by the Oklahoma Commissioner of Labor.
- b. The successful bidder will be responsible for having like requirements placed upon any subcontractor.
- c. The successful bidder will submit to the Director or his designated representative of the Department of Human Rights any compliance reports involving the bidder and its subcontractors required by Title 31, Chapter 1, Section 9, of the Tulsa Revised Ordinances. The reports shall include information about the residence of each employee in each laboring and trade class applicable to any City project.

SECTION 4. Unresponsive Bids. The failure to submit the documents required by Section 3 shall render a bid unresponsive. Said documents must be submitted prior to the opening of the bids. The Director of the Department of Human Rights Section of City Development is charged with ensuring that all bids comply with Section 3 prior to the bid opening date.

SECTION 5. Duty of Employees and/or Agents of the City of Tulsa. Any employee and/or agent of the City of Tulsa who fails to include the goals for residency requirements found in Section 3 in the plans and specifications for any public improvement may be subject to disciplinary action, including dismissal.

SECTION 6. Severability. The invalidity of any section, subsection, provision or clause or portion of this chapter, or the invalidity of the application thereof to any person or circumstance shall not affect the validity of the remainder of this chapter or the validity of its application to other persons or circumstances.

SECTION 7. Effect Date. This resolution shall take effect as of July 1, 1988.

SECTION 8. Emergency Clause. That an emergency exists for the preservation of the public peace, health and safety, by reason whereof this resolution shall take effect immediately upon its passage, approval and publication.

PASSED, with the emergency clause ruled upon separately and approved this 23rd day of August, 1988.

APPROVED, this 23rd day of August, 1988.

Rodger Randle



Mayor

ATTEST: Philip W. Wood



City Auditor

APPROVED: Neal E. McNeil

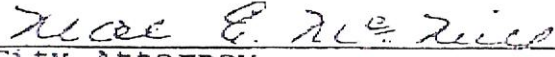

City Attorney

PASSED, with the emergency clause ruled upon separately and approved this 23 day of August, 1988.

- APPROVED, this 23 day of August, 1988.



Mayor

ATTEST:

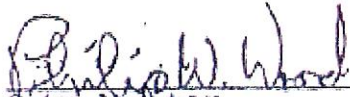

City Auditor

APPROVED:



City Attorney

CITY OF MOBILE
FILED

AUG 23 1988

OFFICE OF CITY AUDITOR

(Must be submitted at time of Bid)
CITY OF TULSA
RESOLUTION NO. 7404
AFFIDAVIT OF COMPLIANCE

_____, of lawful age, being first duly sworn, states that s(he) is the authorized agent of the Company set forth below.

Affiant further states that the Company, in compliance with City of Tulsa Resolution No. 7404, shall not hire or knowingly allow any of its subcontractors or lower tier subcontractors to hire anyone who is not a United States citizen or legal immigrant or anyone who does not have legal status as a temporary worker to perform work on any project which is the subject of a contract between the Company and the City of Tulsa.

Affiant further states that the Company shall not fail to comply with and shall not knowingly allow any of its subcontractors or lower tier subcontractors to fail to comply with all applicable laws including, but not limited to, labor, employment and taxation laws, in the performance of any work on any project which is the subject of a contract between the Company and the City of Tulsa.

Affiant further states that the Company shall make available to the City of Tulsa, at the City's request, sufficient information and/or affirmations to allow the City to confirm Company's compliance with Resolution No. 7404 relating to the performance of any contract between the Company and the City of Tulsa.

Company: _____

Signed: _____

Title

SUBSCRIBED and SWORN to before me, this _____ day of _____, 20__.

NOTARY PUBLIC

MY COMMISSION EXPIRES:

COMMISSION NO.:

(Must be submitted at time of Bid)
CITY OF TULSA
50% RESIDENT RESOLUTION
AFFIDAVIT FOR BID

STATE OF _____)
) ss:
COUNTY OF _____)

_____, of lawful age, being first duly sworn, states that s(he) is the agent authorized by the bidder to submit the attached bid. Affiant further states that the bidder, in compliance with City of Tulsa Resolution No. 18145, is committed to the goal of employing at least 50% bona fide residents of the City of Tulsa and/or the Metropolitan Statistical Area (composed of Creek, Okmulgee, Osage, Pawnee, Rogers, Tulsa, and Wagoner counties).

Affiant further states that bidder is responsible for having like requirements placed upon any of its subcontractors.

BIDDER (Company Name)

SIGNED

Title

SUBSCRIBED and SWORN to before me this ____ day of _____, 20__.

NOTARY PUBLIC

MY COMMISSION EXPIRES:

COMMISSION NO.:

(Must be submitted at time of bid)
NON-COLLUSION AFFIDAVIT

STATE OF _____)
) ss:
COUNTY OF _____)

_____, of lawful age, being first duly sworn, says that:

1. I am the duly authorized agent of the bidder submitting the competitive bid associated with this sworn statement for the purpose of certifying facts pertaining to the existence of collusion among bidders and between bidders and municipal officers or employees, as well as facts pertaining to the giving or offering of things of value to governmental personnel in return for special consideration in the letting of any contract pursuant to the bid;
2. I am fully aware of the facts and circumstances surrounding the making of the bid and have been personally and directly involved in the proceedings leading to the submission of such bid;
3. Neither the bidder nor anyone subject to the bidder's direction or control has been a party:
 - a. to any collusion among bidders in restraint of freedom of competition by agreement to bid at a fixed price or to refrain from bidding;
 - b. to any collusion with any municipal official or employee as to quantity, quality or price in the prospective contract, or as to any other terms of such prospective contract; nor
 - c. in any discussions between bidders and any municipal official concerning exchange of money or other things of value for special consideration in the letting of a contract.
4. If awarded the contract, neither the bidder nor anyone subject to the bidder's direction or control has paid, given or donated or agreed to pay, give or donate to any officer or employee of the City of Tulsa or of any public trust where the City of Tulsa is a beneficiary, any money or other thing of value, either directly or indirectly, in procuring the contract for which the bid is submitted.

BIDDER (Company Name)

Signed

Title

SUBSCRIBED and SWORN to before me this _____ day of _____, 20__.

NOTARY PUBLIC

MY COMMISSION EXPIRES: _____

COMMISSION NO.: _____

INTEREST AFFIDAVIT

STATE OF _____)
)ss.
COUNTY OF _____)

I, _____, of lawful age, being first duly sworn, state that I am the agent authorized by Contractor, Engineer, Architect or provider of professional service ["Services Provider"] to submit the attached Agreement. Affiant further states that no officer or employee of the City of Tulsa either directly or indirectly owns a five percent (5%) interest or more in the Services Provider's business or such a percentage that constitutes a controlling interest. Affiant further states that the following officers and/or employees of the City of Tulsa own an interest in the Services Provider's business which is less than a controlling interest, either direct or indirect.

By _____
Signature

Title _____

Subscribed and sworn to before me this _____ day of _____, 20__.

Notary Public

My Commission Expires: _____

Notary Commission Number: _____

County & State Where Notarized: _____

The Affidavit must be signed by an authorized agent and notarized.

(Must be submitted at time of bid)
BUSINESS RELATIONSHIP AFFIDAVIT

STATE OF)
) ss:
COUNTY OF)

_____, of lawful age, being first duly sworn, says that s(he) is the agent authorized by the bidder to submit the attached bid. Affiant further states that the nature of any partnership, joint venture or other business relationship presently in effect or which existed within one (1) year prior to the date of this statement with the architect, engineer, or other party to the project is as follows:

Affiant further states that any such business relationship presently in effect or which existed within one (1) year prior to the date of this statement between any officer or director of the bidding company and any officer or director of the architectural or engineering firm or other party to the project is as follows:

Affiant further states that the names of all persons having any such business relationships and the positions they hold with their respective companies or firms are as follows:

(If none of the business relationships herein above mentioned exist, affiant should so state.)

Signed: _____

BIDDER (Company Name)

Title:

SUBSCRIBED and SWORN to before me this _____ day of _____, 20__.

NOTARY PUBLIC

MY COMMISSION EXPIRES:
_____, _____

COMMISSION NO.:

PROPOSAL
PROJECT NO: ES-2025-SOM5

TO: TULSA METROPOLITAN UTILITY AUTHORITY
CITY OF TULSA, OKLAHOMA

THE UNDERSIGNED BIDDER, having carefully examined the drawings, specifications, and other Contract Documents of the above project presently on file in the City Clerk, City of Tulsa Oklahoma:

CERTIFIES THAT he has inspected the site of the proposed work and has full knowledge of the extent and character of the work involved, construction difficulties that may be encountered, and materials necessary for construction, class and type of excavation, and all other factors affecting or which may be affected by the specified work; and

CERTIFIES THAT he has not entered into collusion with any other bidder or prospective bidder relative to the project and/or bid: and

HEREBY PROPOSES: to enter into a contract to provide all necessary labor, materials, equipment and tools to completely construct and finish all the work required by the Contract Documents hereto attached and other documents referred to therein: to complete said work within 365 calendar days after the work order is issued; and to accept in full payment therefore the amount set forth below for all work actually performed as computed by the Engineer as set forth in the Contract.

Basis of Award

IT SHOULD BE NOTED THAT THE LOWEST RESPONSIBLE BID SHALL BE DETERMINED BY THE TOTAL BASE BID. CONTRACT AWARD AT THE SOLE DISCRETION OF THE CITY OF TULSA.

Note: - Item numbers omitted are not a part of the Contract.

**ESTIMATE OF QUANTITIES
PROJECT NO. ES-2025-SOM5**

BID ITEM	SPEC NO.	DESCRIPTION	UNIT	QTY	UNIT PRICE	AMOUNT
1	400	Mobilization/Demobilization Per Spec. No 400 (One each per contract)	EA	1		
2	400, SP-5	Digital photographic documentation Per Spec. No 400 (One lump sum per contract)	LS	1		
3	415	Video Pre and Post Inspection (For each linear foot)	LF	3,450		
4	416	4' Diameter Manhole Replacement	EA	11		
5	416	4' Diameter Manhole Additional Vertical Foot over 6 foot depth	VF	10		
6	417, SP-9	Lamphole Replacement Per Spec. No 417	EA	1		
7	409	Slipline 8" Diameter Host Pipe w/PE pipe (per linear foot)	LF	225		
8	409, SP-10	Service Reconnection (For each service reconnected during Slipline)	EA	8		
9	408, SP-11	Pipeburst 8" Diameter Host Pipe w/ PE pipe (per linear foot)	LF	2780		
10	SP-10	Service Reconnection (For each service reconnected during Pipeburst)	EA	33		
11	405, SP-12	Opencut 8" Diameter Host Pipe (per linear foot) SDR 26	LF	440		
12	405	Service Reconnection (For each service reconnected during Opencut)	EA	7		
13	SP-13	Excessive depth on repair (Per vertical foot exceeding 15 feet)	VF	2		
14	423, SP-14	Obstruction Removal per Spec. No 423	EA	5		
15	SP-15	Dewatering operation (per pump per day)	EA	5		
16	SP-16	External Drop	EA	3		
17	SP-18	Specialty Work Allowance	Allow	1	\$10,000.00	\$10,000.00
Base Bid Total						\$10,000.00

BASE BID

\$0.00

Enclosed is a () Bidder's Surety Bond, () Certified Check, () Cashier's Check for

_____ Dollars (\$ _____) Figures

which the City of Tulsa may retain or recover as liquidated damages in the event that the undersigned fails to enter into contract for the work covered by this proposal., provided the Contract is awarded to the undersigned within thirty (30) days, or within ninety (90) days if Federal funds are utilized, from the date fixed for opening of bids and the undersigned fails to execute said Contract and furnish the required bonds and other requirements as called for in these Contract Documents within thirty (30) days after award of Contract.

Dated at Tulsa, Oklahoma, this _____ day of _____, 20__.

Respectfully submitted,

(Complete legal name of company)

(State of Organization)

By:

ATTEST:

Title:

Title: Corporate Secretary

Printed Name:

Printed Name:

(SEAL)

Address: _____

Telephone Number: _____

Fax Number: _____

By signing above the bidder acknowledges receipt of the following Addenda (give number and date of each):

Revised 10/06/09)

This form is made available for example purposes only and is not intended to be legal advice nor intended to be relied upon in lieu of consultation with an attorney.

Certificate of Secretary

The undersigned _____ (Assistant) Secretary of _____, a _____ corporation, (the "Corporation") hereby certifies that the following is a true and correct copy of a Resolution duly adopted by the Board of Directors of the Corporation on the _____ day of _____, 20____.

RESOLVED, that _____ is authorized to execute an enter into bids, contracts, bonds, affidavits and any ancillary documents, on behalf of the Corporation.

The undersigned further certifies that this Resolution is in full force and effect as of the date of this Certificate and has not been amended, modified, revoked or rescinded.

IN WITNESS WHERE OF, I have executed this Certificate this _____ day of _____, 20____.

(Signature)

(Printed Name)

(Assistant) Secretary

SAMPLE

[SAMPLE CONSENT OF MEMBERS]

[NAME OF COMPANY], LLC

Consent of Members

The undersigned, being all of the Members of [Name of Company], LLC, an Oklahoma Limited Liability Company, hereby authorize, consent to, approve and ratify the execution by _____ on behalf of [Name of Company], LLC of bid proposals, contracts, affidavits and related documents in connection with [Name of Project] of the City of Tulsa.

DATED, this _____ day of _____, 20____

Name printed: _____

[ADD ADDITIONAL LINES FOR ADDITIONAL MEMBERS]

Disclaimer Statement: This form is made available for example purposes only and is not intended to be legal advice nor intended to be relied upon in lieu of consultation with an attorney.

CM-1

TULSA METROPOLITAN UTILITY AUTHORITY

9319 E. 42nd Street North

Tulsa, Oklahoma 74115

RE; TULSA METROPOLITAN UTILITY AUTHORITY CONTRACT PROJECT

To Whom It May Concern:

The vendor of materials and supplies under the above referenced contract is hereby authorized to invoice the Tulsa Metropolitan Utility Authority (TMUA), 9319 E. 42nd Street North, Tulsa, OK, 74115, for all materials and supplies purchased under the above contract, noting any contract discount and omitting all sales taxes. All invoices shall include the contract number and the name of the contractor ordering the materials or supplies.

Upon receipt the Tulsa Metropolitan Utility Authority will pay the invoice, in accordance with its terms and conditions, as money is due the Contractor.

This letter of authorization expires.

CITY OF TULSA

Shawn Glen, Division Manager
Water and Sewer Department
Sewer Operations & Maintenance

SG:jkm

EXTENSION OF TIME REQUEST

(to be submitted with each partial payment application)

DATE: _____

CONTRACTOR: _____

ADDRESS: _____

DESCRIPTION OF CONTRACT: _____

EXTENSION OF CONTRACT TIME REQUIRED: YES ___ NO ___

TOTAL OF EXTENSION TIME REQUIRED: _____

IF YES, GIVE REASON: _____

SIGNATURE-CONTRACTOR

CONSULTING ENGINEER OR
DEPARTMENT OF PUBLIC WORKS STAFF RECOMMENDATION

APPROVED: _____ REJECTED: _____

REASON: _____

SIGNATURE

DATE

Action will be taken within 30 days from receipt of Request. A formal Change Order to the Tulsa Metropolitan Utility Authority will be required to consummate the Extension of Time Request.

**CONTRACT FOR CONSTRUCTION OF PUBLIC IMPROVEMENTS
UNDERGROUND COLLECTION SYSTEMS
TULSA, OKLAHOMA**

THIS CONTRACT made and entered into this ____ day of _____, 20____, by and between _____ hereinafter called the "CONTRACTOR", and the TULSA METROPOLITAN UTILITY AUTHORITY, Tulsa, Oklahoma, a Public Trust, herein called the "Authority".

WITNESSETH:

WHEREAS, the Authority has caused to be prepared the necessary Drawings, Specifications, and other Contract Documents for the public improvements herein described, and has invited bids for the construction thereof in accordance with the terms of the Contract, all of which is hereby designated as:

PROJECT NO TMUA ES-2025-SOM5 SANITARY SEWER REHAB & REPAIRS

WHEREAS, the Contractor, in response to the Advertisement, has submitted to the Authority, in the manner and at the time specified, a sealed bid in accordance with the terms of this Contract; and,

WHEREAS, the Authority, in the manner prescribed by law, has publicly opened, examined, and canvassed the bids submitted, and has determined the above-named Contractor to be the lowest responsible bidder for the work and has duly awarded to the said Contractor therefore, for the sum or sums named in the Contractor's bid, a copy of the Bid Form being attached to and made a part of this Contract;

NOW, THEREFORE, in consideration of the compensation to be paid to the Contractor and of the mutual agreements and covenants herein contained, the parties to this Contract have agreed and hereby agree, as follows:

ARTICLE I. That the contractor shall (a) furnish all tools, equipment, supplies, supervision, transportation, and other accessories, services, and facilities; (b) provide and perform all necessary labor; and (c) in a good, substantial, and workmanlike manner and in accordance with the requirements, stipulations, provisions, and conditions of the Contract Documents as defined in the attached General Conditions, said documents forming the Contract and being as fully a part thereof as if repeated verbatim herein, perform, execute, construct, and complete all work included in and covered by the Authority's official award of this Contract to the said Contractor, such award being based on the acceptance by the Authority of the Contractor's bid, or part thereof, as follows:

ARTICLE IIA. That the Authority shall pay to the Contractor for performance of the work embraced in this Contract, and the Contractor will accept as full compensation therefore, the sum (subject to adjustment as provided by the Contract) of _____ for all work covered by and included in the Contract award and designated in the foregoing Article I; payments therefore to be made in cash or its equivalent, in the manner provided in the General Conditions.

ARTICLE III. That the Contractor shall start work within ten (10) days following the date stipulated in a written order from the Authority to proceed with the work to be performed hereunder and shall complete the work within the number of consecutive calendar days after the authorized starting date, as stipulated below: If additional time is necessary, Authority has the option to grant it.

All Work Completed: 365 calendar days

ARTICLE IV. The sworn, notarized statement below shall be signed and notarized before this Contract will become effective.

ARTICLE V. Prior to submitting a final payment request, the Contractor shall furnish a lien waiver certifying that all subcontractors and suppliers have been paid.

IN WITNESS WHEREOF, the Authority and the Contractor hereto have set their hands and seals, respectively, this ____ day of _____, 20__.

APPROVED AS TO SUBSTANCE:

_____ Date: _____
Eric Lee
Water & Sewer Director

TULSA METROPOLITAN UTILITY AUTHORITY, a Public Trust

By:

_____ Date: _____
Chairman

ATTEST:

_____ Date: _____
Secretary

APPROVED AS TO FORM:

_____ Date: _____
Attorney for the Trust

CONTRACTOR

By: _____ Date _____ Title _____ Date: _____

ATTEST:

Corporate Secretary

(SEAL)

AFFIDAVIT

STATE OF _____)
) ss
COUNTY OF _____)

_____, of lawful age, being first duly sworn, on oath that (s)he is the agent authorized by the Contractor to submit the above Contract to the Tulsa Metropolitan Utility Authority, Tulsa, Oklahoma. Affiant further states that the Contractor has not paid, given, or donated or agreed to pay, give, or donate to any officer or employee of the Tulsa Metropolitan Utility Authority, Tulsa, Oklahoma, any money or other thing of value, either directly or indirectly, in the procuring of the contract.

Signature

SUBSCRIBED AND SWORN to before me this _____ day of _____, 20__

NOTARY PUBLIC

My Commission Expires:
_____, _____.

PERFORMANCE BOND

KNOW ALL MEN BY THESE PRESENTS: That we, the undersigned, _____ (hereinafter called the "Contractor"), duly authorized by law to do business as a construction contractor in the State of Oklahoma, and _____ (hereinafter called the "Surety"), a corporation organized under the laws of the State of _____, and authorized to transact business in the State of Oklahoma, as Surety, are hereby held and firmly bound unto the Tulsa Metropolitan Utility Authority, Tulsa, Oklahoma, (hereinafter called the "Authority"), in the penal sum of _____ (full amount of the Contract), lawful money of the United State, for the payment of which, well and truly to be made unto the said Authority, we bind ourselves, our heirs, executors, engineers, successors, and assigns, jointly and severally, firmly by these presents, as follows:

THE CONDITION OF THE FOREGOING OBLIGATION IS SUCH THAT, WHEREAS, the Contractor has on the ____ day of _____ 20__, entered into a written contract with the Tulsa Metropolitan Utility Authority, Tulsa, Oklahoma, for furnishing all materials, labor, tools, equipment, and transportation necessary for:

PROJECT NO TMUA ES-2025-SOM5 SANITARY SEWER REHAB & REPAIRS

NOW, THEREFORE, if said Contractor shall well and truly perform and complete said project in accordance with said Contract, Advertisement for Bids, General Conditions, Instructions to Bidders, Bid Form, Plans and Specifications, and related documents, shall comply with all the requirements of the laws of the State of Oklahoma; shall pay as they become due all just claims for work or labor performed and materials furnished in connection with said contract, and shall defend, indemnify and save harmless said Authority against any and all liens, encumbrances, damages, claims, demands, expenses, costs and charges of every kind, including patent infringement claims except as otherwise provided in said specifications and other contract documents, arising out of or in relation to the performance of said work and the provisions of said Contract, then these presents shall be void; otherwise, they shall remain in full force and effect.

This obligation is made for the use of said Authority and also for the use and benefit of all persons who may perform work or labor or furnish any material in the execution of said Contract, and may be sued on thereby in the name of the Authority.

The Surety, for value received, hereby stipulates and agrees that no change, extension of time, alteration or addition to the terms of the Contract, or to the work to be performed thereunder, or the specifications accompanying same, shall in any way affect its obligation on this bond; and it does hereby waive notice of any such change, extension of time, alteration or addition of the terms of the Contract, or to the work or to the specifications.

IN WITNESS WHEREOF, the said Principal has caused these presents to be executed in its name and its corporate seal to be hereunto affixed by its duly authorized officers, and the said Surety has caused these presents to be executed in its name and its corporate seal to be hereunto affixed by its attorney-in-fact, duly authorized so to do, the day and year first above written.

CONTRACTOR (Principal)

BY:

ATTEST: (S E A L)

Date: _____ Date: _____

Title: _____

Title: Corp. Sec

Date: _____ Date: _____

Attorney-In-Fact

Surety (S E A L)

** This date shall match the date of the notarized certificate on the Power of Attorney
(Accompany this Bond with Power-Of-Attorney)

APPROVED AS TO FORM:

Date: _____
Attorney for the Tulsa Metropolitan
Utility Authority

APPROVED AS TO FORM:

Date: _____
City Attorney

Date: _____
City Clerk

STATUTORY BOND

WHEREAS, the undersigned _____ has entered into a certain contract dated the ___ day of _____, 20__ designated and shown as TMUA ES-2025-SOM5 for the construction of certain public improvements consisting of SANITARY SEWER REHAB & REPAIRS, to be situated and constructed on and through the property described in said Contract, including all of the work mentioned and described in said Contract, and to be performed by the undersigned strictly and punctually in accordance with the terms, conditions, drawings and specifications thereof, on file in the office of the Tulsa Metropolitan Utility Authority.

NOW, THEREFORE, KNOW ALL MEN BY THESE PRESENTS: That _____ as Principal, and _____, a Corporation organized under the laws of the State of _____ and authorized to transact business in the State of Oklahoma, as Surety, are held and firmly bound unto the Tulsa Metropolitan Utility Authority and the State of Oklahoma in the penal sum of (Full Amount of Contract) lawful money of the United States, for the payment of which sum well and truly to be made, we bind ourselves, our successors, and assigns, jointly and severally firmly by these presents.

NOW, THEREFORE, if the said Principal shall fail or neglect to pay all indebtedness incurred by Principal or sub-contractors of said principal who perform work in the performance of such contract, for labor and materials and repairs to and parts for equipment used and consumed in the performance of said contract within thirty (30) days after the same becomes due and payable, the person, firm or corporation entitled thereto may sue and recover on this bond the amount so due and unpaid.

The Surety, for value received, hereby stipulates and agrees that no charge, extension of time, alteration, or addition to the terms of the contract or to the work to be performed thereunder, or the specifications accompanying the same, shall in any way affect its obligation on this bond, and it does hereby waive notice of any such change, extension of time, alteration, or addition to the terms of the contract or to the specifications.

IN WITNESS WHEREOF, the said Principal has caused these presents to be executed in its name and its corporate seal to be hereunto affixed by its duly authorized officers, and the said Surety has caused these presents to be executed in its name and its corporate seal to be hereunto affixed by its attorney-in-fact, duly authorized so to do, the day and year first above written.

CONTRACTOR (Principal)

BY: _____ ATTEST: (SEAL)
_____ Date: _____ _____ Date: _____

Title: _____ Title: Corp. Sec.

_____ Date: _____ _____ Date: _____
Attorney-In-Fact Surety (SEAL)

** This date shall match the date of the notarized certificate on the Power of Attorney
(Accompany this Bond with Power-Of-Attorney)

APPROVED AS TO FORM:

Attorney for the Tulsa Metropolitan
Utility Authority Date: _____

APPROVED AS TO FORM:

City Attorney Date

City Clerk Date

MAINTENANCE BOND

KNOW ALL MEN BY THESE PRESENTS:

That _____, as Principal, and _____, a corporation organized under the laws of the State of _____ and authorized to transact business in the State of Oklahoma, as Surety, are held and firmly bound unto the Tulsa Metropolitan Utility Authority, in the Penal sum of _____ (Full Amount of Contract) in lawful money of the United State of America for the payment of which, well and truly to be made, we bind ourselves and each of us, our heirs executors, egnieers, trustees, successors, and assigns, jointly and severally, firmly by these presents.

The condition of this obligation is such that:

WHEREAS, said Principal entered into a written contract with the Tulsa Metropolitan Utility Authority dated this _____ day of _____, 20____, for

PROJECT NO TMUA ES-2025-SOM5 SANITARY SEWER REHAB & REPAIRS

all in compliance with the drawings and specifications therefore, made a part of said Contract and on file in the office of the Authority, Tulsa, Oklahoma.

NOW, THEREFORE, if said Principal shall pay or cause to be paid to the Tulsa Metropolitan Utility Authority, all damage, loss, and expense which may result by reason of defective materials and/or workmanship in connection with said work, occurring within a period of one (1) year for all projects, from and after acceptance of said project by the Tulsa Metropolitan Utility Authority and if Principal shall pay or cause to be paid all labor and materials, including the prime contractor and all subcontractors; and if principal shall save and hold the Tulsa Metropolitan Utility Authority harmless from all damages, loss, and expense occasioned by or resulting from any failure whatsoever of said Principal, then this obligation shall be null and void, otherwise to be and remain in full force and effect.

It is further expressly agreed and understood by the parties hereto that no changes or alterations in said Contract and no deviations from the plan or mode of procedure herein fixed shall have the effect of releasing the sureties, or any of them, from the obligation of this Bond.

IN WITNESS WHEREOF, the said Principal has caused these presents to be executed in its name and its corporate seal to be hereunto affixed by its duly authorized officers, and the said Surety has caused these presents to be executed in its name and its corporate seal to be hereunto affixed by its attorney-in-fact, duly authorized so to do, the day and year first above written.

CONTRACTOR (Principal)

BY: _____ ATTEST: (SEAL)

Date: _____ Date: _____
Title: _____ Title: Corp. Sec.

Date: _____ Date: _____
Attorney-In-Fact ** Surety (SEAL)

** This date shall match the date of the notarized certificate on the Power of Attorney

(Accompany this Bond with Power-Of-Attorney)

APPROVED AS TO FORM:

Attorney for the Tulsa Metropolitan
Utility Authority
Date: _____

APPROVED AS TO FORM:

City Attorney
Date

City Clerk
Date

AFFIDAVIT OF CLAIMANT

STATE OF _____)
)SS.
COUNTY OF _____)

CONTRACT # _____

The undersigned person, of lawful age, being first duly sworn on oath, says that all invoices to be submitted pursuant to this agreement with the Tulsa Metropolitan Utility Authority will be true and correct. Affiant further states that the work, services or material furnished will be completed or supplied in accordance with the plans, specifications, orders, requests or contract furnished or executed by the affiant. Affiant further states that (s)he has made no payment directly or indirectly to any elected official, officer or employee of the City of Tulsa or of any public trust where the City of Tulsa is a beneficiary, of money or any other thing of value to obtain payment of the invoice or procure the contract or purchase order pursuant to which an invoice is submitted. Affiant further certifies that (s)he has complied with all applicable laws regarding equal employment opportunity.

Company: _____

TIN: _____

Remit to Address: _____

City, State, Zip: _____

Phone: _____

Signature: _____

Title: _____

Subscribed and sworn to before me this _____ day of _____

Notary Public

My commission expires:

Commission Number:

General Conditions

GENERAL CONDITIONS OF CONTRACT
TABLE OF CONTENTS

Section	Title
GC-1	Scope
GC-2	Contract Documents
GC-3	Definitions
GC-4	Modifications and Alterations
GC-5	Drawings To Be Furnished By the Contractor
GC-6	Contractor's Business Address
GC-7	Contractor's Risk and Responsibility
GC-8	Assignment and Subletting of Contract
GC-9	Contractor's Representatives
GC-10	Contractor and his Employees
GC-11	Contractor's Right of Protest
GC-12	Insurance and Bonds
GC-13	Time for Completion
GC-14	Extensions of Time
GC-15	Authority's Representative's Powers and Duties
GC-16	Authority's Right of Inspection
GC-17	Suspension of Work on Notice
GC-18	Quality of Workmanship
GC-19	Saturday, Sunday, Holiday, and Night Work
GC-20	Laws and Ordinances
GC-21	Taxes and Permits
GC-22	Protection of Property
GC-23	Patent Rights
GC-24	Defense of Suits
GC-25	Removal of Condemned Materials and Structures
GC-26	Extra Work
GC-27	Payment for Contractor's Plant and Miscellaneous Temporary Work
GC-28	Basis of Payment for Items of Work
GC-29	Payments
GC-30	Contractor Reimbursement for Surety Bond
GC-31	Release of Liability and Acceptance
GC-32	Right of Authority to Terminate Contract
GC-33	Administrative Cost and Fees
GC-34	Payment or Acceptance not a Waiver by Authority
GC-35	Contractor's Obligation after Acceptance
GC-36	Notices
GC-37	Relation to other Contractors
GC-38	Partial Occupancy and Use

GENERAL CONDITIONS OF CONTRACT

GC-1. SCOPE:

The Contract stipulations which follow are general in scope and may refer to conditions which will not be encountered in the performance of the work included in this Contract, and which are not applicable thereto. Any requirements, provisions, or other stipulations of these General Conditions which pertain to a nonexistent condition, and are not applicable to the work to be performed hereunder, shall have no meaning in the Contract.

The specifications and drawings are intended to supplement, but not necessarily duplicate each other. Together they constitute one (1) complete set of specifications and drawings, so that any work exhibited in the one and not in the other shall be executed just as if it had been set forth in both, in order that the work shall be completed according to the complete design or designs as decided and determined by the Engineer.

Should anything be omitted from the specifications and drawings which is necessary to a clear understanding of the work, or should it appear various instructions are in conflict, then the Contractor shall request written clarification from the Engineer before proceeding with the construction affected by such omissions or discrepancies.

GC-2. CONTRACT DOCUMENTS:

It is understood and agreed that the Notice to Bidders, Instructions to Bidders, Proposal, Contract, Statutory Bond, Performance Bond, Maintenance Bond, Power of Attorney, Certificates of Insurance, General Conditions, Specifications, Drawings, Addenda and duly authorized Change Orders, together with any and all supplementary drawings furnished by the Engineer as and when required to make clear and to define in greater detail the intent of the contract, drawings, and specifications, other drawings, specifications, and engineering data furnished by the Contractor (when accepted by the Engineer), and instructions furnished by manufacturers of equipment for the installation thereof, are each and all included in this Contract, and the work shall be done in full compliance and accord therewith.

GC-3. DEFINITIONS:

Any word, phrase, or other expression defined in this paragraph and used in these Contract Documents shall have the meaning herein given:

1. "Contract" or "Contract Documents" shall include all of the documents and drawings mentioned in Paragraph GC-2.
2. "Authority" shall mean the Tulsa Metropolitan Utility Authority, Tulsa County, Oklahoma, a Public Trust.

3. "Contractor" shall mean the entity named and designated in the Contract who has entered into this Contract to perform the work covered thereby, and its, his, or their duly authorized agents and other legal representatives.

4. "Engineer" shall mean the Superintendent of Water Plant or Sewer Plant, or the Architect or Engineers who have been designated, appointed, or employed by the Authority and Superintendent of Water Plant or Sewer Plant for this project, or their duly authorized agents; such agents acting within the scope of the particular duties entrusted to them in each case.

5. "Inspector" shall mean the engineering or technical inspector or inspectors duly authorized by the Engineer, limited in each case to the particular duties entrusted to him or them.

6. "Surety" shall mean any entity that executes, as surety, the Contractor's performance bond, maintenance bond, and statutory bond securing the performance of this Contract.

7. "Drawings" shall mean and include all drawings prepared by the Authority as a basis for proposals; all drawings submitted by the successful bidder with his proposal and by the Contractor to the Authority, when and as accepted by the Engineer, and all drawings submitted by the Authority to the Contractor during the progress of the work as provided herein.

8. "Subcontractor" shall mean a person, firm or corporation to whom any portion of this work has been sublet by the Contractor.

9. "Work" shall mean the task to be performed, necessary for the fulfillment of this Contract.

10. "Unit Price" shall mean the cost per specified unit of measurement of work and/or material.

11. "Lump Sum" shall mean the price of an item of work including all things necessary to complete the item as shown on the drawings and specifications. Such an item is not measured in units but is defined by description.

GC-4. MODIFICATIONS AND ALTERATIONS:

In executing the Contract, the Contractor agrees that the Authority shall have the right to make such modifications, changes, and alterations as the Authority may see fit, in the extent or plan of the Work agreed to be done or any part thereof, or in the materials to be used therein, either before or after the beginning of construction thereof, without affecting the validity of the Contract or the liability of the Sureties upon the performance of this Contract or the Statutory Bond.

Where any modification, change, or alteration increases the quantity of Work to be performed, and is within the scope of a fair interpretation thereof, such increase shall be paid for according to the quantity of work actually done, either at Unit Prices included in the Contract, or in the absence of such unit, as extra Work. Modifications and alterations which reduce the quantity of Work to be done shall not constitute a claim for damages or for anticipated profits on Work involved in such reduction.

The Engineer shall determine, on an equitable basis, the amount of credit due the Authority for Work not performed as a result of modifications or alterations authorized hereunder; where the value of the omitted Work is not fixed by Unit Prices in the Contract; allowance to the Contractor for any actual loss incurred in connection with the purchase, delivery, and subsequent disposal of materials and equipment required for use on the Work as actually built; and any other adjustment of the Contract amount where the method to be used in making such adjustment is not clearly defined in the Contract Documents. In this respect, such determination shall be final and binding only when approved by the Superintendent of Water Plant or Sewer Plant.

GC-5. DRAWINGS TO BE FURNISHED BY CONTRACTOR:

The Contractor shall furnish all shop, fabrication, assembly, foundation, and other drawings required by the specifications; drawings of equipment and devices, offered by the Contractor for review by the Engineer shall be in sufficient detail to show adequately the construction and operation thereof; drawings of essential details of any change in design or construction proposed for consideration of the Engineer, by the Contractor in lieu of the design or arrangement required by the Contract or any item of extra work thereunder. The Contractor shall submit to the Engineer, the required number of each copy of such drawing for the Engineer's review. After review by the Engineer, all such drawings shall become a part of the Contract Documents and the work or equipment shown thereby shall be in conformity therewith unless otherwise required by the Authority.

The Engineer's check and acceptance of drawings submitted by the Contractor will be for, and will cover, only general conformity to the plans and specifications and will not constitute a blanket acceptance of all dimensions, quantities, and details of the material or equipment shown; nor shall such acceptance relieve the Contractor of his responsibility for errors contained in such drawings.

GC-6. CONTRACTOR'S BUSINESS ADDRESS:

The business address of the Contractor given in the bid or proposal upon which this Contract is founded is hereby designated as the place to which all notices, letters, and other communications to the Contractor may be mailed or delivered. The delivery at the above named address, or depositing in any mailbox regularly maintained by the Post Office, of any notice, letter, or other communication to the Contractor, shall be deemed sufficient service thereof upon the Contractor and the date of said service shall be the date of such delivery or mailing. Such address may be changed at any time by a written instrument, executed by the Contractor and delivered to the Engineer. Nothing contained herein shall be deemed to preclude or render inoperative the service of any notice, letter, or communication upon the Contractor personally.

GC-7. CONTRACTOR'S RISK AND RESPONSIBILITY:

The performance of the Contract and the Work is at the risk of the Contractor until the final acceptance thereof and payment therefor. The Contractor shall take all responsibility of the Work, and shall bear all losses resulting because of the amount or character of the Work, or because the nature of the land in or on which the Work is done is different from what is assumed or expected, or on account of the weather, floods, fire, windstorm, or other actions of the elements, or any cause or causes, whatsoever, for which the Authority is not responsible. If the Work or any part or parts thereof is destroyed or damaged from any of the aforesaid causes, the Contractor, at his own cost or expense, shall restore the same or remedy the damage.

The Contractor shall, in a good and workmanlike manner, perform all Work and furnish all supplies and materials, machinery, equipment, facilities, and means, except as otherwise expressly specified, necessary or proper to perform and complete all Work required by the Contract within the time herein specified, in accordance with the provisions of these Contract Documents and Drawings of the Work covered by this Contract, and any and all supplemental Drawings. The Contractor shall observe, comply with, and be subject to all terms, conditions, requirements and limitations of the Contract, and shall complete the entire Work to the satisfaction of the Engineer and of the Authority.

GC-8. ASSIGNMENT AND SUBLETTING OF CONTRACT:

The Contractor shall give his personal attention to the fulfillment of this Contract, and shall not let, assign or transfer it or his right, title, or interest in any part thereof, by attorney or otherwise, or sublet any part of the Work to any other person without the prior consent of the Authority in writing.

Should any Subcontractor fail to perform his Work in a satisfactory manner, his subcontract shall be immediately terminated by the Contractor upon notice from the Authority. The Contractor shall be fully responsible to the Authority for the acts and omissions of his Subcontractor and of persons either directly or indirectly employed by his Subcontractor. Nothing contained in these Contract Documents shall create any contractual relation between any Subcontractor and the Authority.

GC-9. CONTRACTOR'S REPRESENTATIVES:

The Contractor shall designate a person on the Work to represent him when absent from the Work site.

GC-10. CONTRACTOR AND HIS EMPLOYEES:

The Contractor shall employ competent foremen, experienced mechanics, and others skilled in the several parts of the Work in this Contract and shall promptly discharge any and all incompetent or otherwise unsatisfactory employees. Contractor's employees directly employed to perform the Work shall not be paid less than the prevailing minimum wage scale.

Necessary sanitary conveniences for the use of employees on the job site, properly secluded from public observation, shall be provided and maintained by the Contractor. The construction and location of the facility and disposal of the contents shall comply with all laws of the City and State, relating to health and sanitation regulations.

GC-11. CONTRACTOR'S RIGHT OF PROTEST:

If the Contractor considers any work demanded of him to be outside the requirements of the Contract, or considers any record or ruling of the Engineers to be unfair, he shall, immediately upon such Work being demanded or such record or ruling being made, ask for written instructions or decisions, whereupon he shall proceed without delay to perform the Work or to conform to the record or ruling, and within ten (10) days after the date of receipt of written instructions or decision, he shall file a written protest with the Engineer, stating clearly and in detail the basis of his objections. Except for such protests and objections made of record in the manner herein specified and within the time stated, the records, rulings, or decisions of the Engineer shall be final and conclusive.

GC-12. INSURANCE AND BONDS:

The Contractor (and any subcontractors) shall carry and keep in force during this Contract, policies of insurance issued by an insurer authorized to transact business in Oklahoma in minimum amounts as set forth below or as required by the laws of the State of Oklahoma. The Contractor shall also furnish an Owner's Protective Policy in the same amounts naming the Tulsa Metropolitan Utility Authority as the assured, issued by the same insurance company as the Contractor's liability coverage and indemnifying the Authority against any and all actions, claims, judgments or demands arising from injuries of any kind and character sustained by any person or persons because of work performed by the Contractor.

General Liability Insurance with a bodily injury and property damage combined single limit of not less than \$1,000,000.00 for each occurrence.

Employer's Liability and Workmen's Compensation in the amounts as required by law.

The Contractor shall provide proof of such coverage:

- (a) By providing Certificate(s) of Insurance prior to the execution of this contract; and
- (b) By submitting updated Certificate(s) of Insurance with each and every subsequent request for payment. The Certificate(s) should show that the policies are current and should be dated within 30 days of the payment request.

The Contractor shall not cause any required insurance policy to be cancelled or permit it to lapse. If the Contractor cancels, allows to lapse, fails to renew or in any way fails to keep any required insurance policy in effect, the Authority will suspend all progress

and/or final payments for the project until the required insurance is obtained. Further, a Contractor who fails to keep required insurance policies in effect may be deemed by the Authority to be in breach of contract, ineligible to bid on future projects, and/or ineligible to engage in any new contracts.

The Contractor shall execute and furnish a Statutory Bond for the protection of laborers, mechanics, and material men in a sum equal to one hundred percent (100%) of the contract price.

The Contractor shall execute and furnish a Performance Bond in a sum equal to one hundred percent (100%) of the contract price.

The Contractor shall execute and furnish a Maintenance Bond in a sum equal to one hundred percent (100%) of the contract price.

Prior to doing blasting, the Contractor shall furnish a Certificate of Insurance, which shall certify that any damage caused by blasting is within the coverage of the Contractor's liability insurance to the full limits thereof.

All bonds and insurance must be executed by a company licensed to do business in the State of Oklahoma, and must be acceptable to the Authority.

GC-13. TIME FOR COMPLETION:

The Work shall commence within ten (10) days from and after the date of a written order from the Authority. The Contractor agrees that the Work shall be performed regularly, diligently, and uninterruptedly at a uniform rate of progress so as to insure completion within the number of days after the day on which the work order is issued. If the Contractor fails to complete all Work within the time specified, then the Contractor agrees to pay the Authority, not as a penalty, but as liquidated damages for such breach of contract, the sum of **Two Thousand Five Hundred Dollars (\$2,500.00)** for each and every calendar day beyond the date on which the work was to be completed. The said amount is fixed and agreed upon because of the impracticability and extreme difficulty of fixing and ascertaining the actual damages the Authority would sustain in such event. It is expressly understood and agreed that the said time for the completion of the Work described herein is a reasonable time for the completion of the same.

The Contractor shall commence work within twenty-four (24) hours of traffic control devices being established at the project location. If the Contractor fails to commence work within twenty-four (24) hours of traffic control devices being established at the project location, then the Contractor agrees to pay the Authority, not as a penalty, but as liquidated damages the sum of **One Thousand Dollars (\$1000.00)** per lane for each day of failure to commence work after the specified time set forth. The amount is fixed and agreed upon because of the impracticability and extreme difficulty of fixing and ascertaining the actual damage the Authority would sustain in such event.

Within 14 days after Bid Opening and prior to Award of Bid the successful Contractor

will be required to furnish the Engineer with a progress schedule, in a format approved by the Engineer, setting forth in detail the procedure he proposes to follow, and giving the dates on which he expects to start and to complete separate portions of the Work. If at any time, in the opinion of the Engineer, proper progress is not being maintained, such changes shall be made in the schedule of operations, which will satisfy the Engineer that the Work will be completed within the period stated in the proposal. Monthly progress meetings will be conducted to maintain coordination between all project entities.

The Contractor will be required to provide a full-time, onsite English speaking superintendent for this Work for direct contact with Authority and coordination of Subcontractors. A working foreman is not acceptable as a work superintendent. The superintendent shall be required to be present at the Work site whenever the Contractor or Subcontractors are performing Work. The superintendent shall be a representative of the Contractor with the authority to make decisions. If the Contractor fails to provide a non-working superintendent on a day when Work is being performed the Contractor agrees to pay the Authority, not as a penalty, but as liquidated damages for such breach of contract, the sum of **One Thousand Dollars (\$1000.00)** for each and every calendar day it fails to provide a non-working superintendent at the Work site. This amount is fixed and agreed upon because of the impracticability and extreme difficulty of fixing and ascertaining the actual damages the Authority would sustain in such event.

It is further agreed that time is of the essence as to each and every portion of this Contract and the specifications wherein a definite and certain time is fixed for the performance of any act whatsoever; and where under the Contract an allowance of additional time for completion of any Work is made, the new time fixed by such extension shall be of the essence of this Contract.

Failure to complete the Work within the specified time, as set forth in the Contract, may be grounds for disqualification for future consideration for contracts with the Authority.

Final acceptance of the Work is defined as the completion of the Work and the Contractor moving off the project site. No defined or additional Work is needed.

Contract Evaluation forms will be compiled by Authority staff upon completion of Work to provide a record of the Contractor's performance for use in subsequent projects.

GC-14. EXTENSIONS OF TIME:

Should the Contractor be delayed in the final completion of the Work by any act or neglect of the Authority or Engineer, or any employee of either, or strikes, injunctions, fire, or other causes outside of and beyond the control of the Contractor and which, in the opinion of the Engineer, could have been neither anticipated nor avoided, then an extension of time sufficient to compensate for the delay, as determined by the Engineer, shall be granted by the Authority, provided, however, that the Contractor shall give the Authority and the Engineer notice in writing of the cause of each delay on the "Extension of Time Request" form enclosed in these documents, and agrees that any such claim shall be fully compensated for by an extension of time to complete

performance of the Work.

The Contractor shall submit the "Extension of Time Request" form with each partial payment application. Failure to submit the Extension of Time Request with a partial payment application shall constitute a complete waiver of any claim for time extension for the period covered by the partial payment.

Extensions of time will not be granted for delays caused by unsuitable ground conditions, inadequate construction force, or the failure of the Contractor to place orders for equipment or materials a sufficient time in advance to insure delivery when needed. Any extension of time granted by the Authority shall not release the Contractor and Surety herein from the payment of liquidated damages as provided in the General Conditions of this Contract, for a period of time not included in the original Contract or the time extension, as herein provided.

In no event shall the Authority be liable or responsible to the Contractor, Surety, or any person for or on account of any stoppage or delay of Work herein provided for by injunction or any other kind of legal, equitable proceedings, or from or by or on account of any delay from any other cause whatsoever.

GC-15. ENGINEER'S POWERS AND DUTIES:

The Engineer will provide general administration of the Contract, including performance of the functions hereinafter described.

The Engineer will be the Authority's representative during construction and until final payment. The Engineer will have authority to act on behalf of the Authority to the extent provided herein unless otherwise modified by written instrument, which will be shown to the Contractor. The Engineer will advise and consult with the Authority, and all of the Authority's instructions to the Contractor shall be issued through the Engineer. Nothing contained in the Contract documents shall create any contractual relationship between the Engineer and the Contractor.

The Engineer shall at all times have access to the Work as provided elsewhere herein. The Engineer will make periodic visits to the Work site to familiarize himself generally with the progress and quality of the Work and to determine in general whether the Work is proceeding in accordance with the Contract. On the basis of his on-site observations as Engineer, he will keep the Authority informed of the progress of the Work and will endeavor to guard the Authority against defects and deficiencies in the Work caused by the Contractor. The Engineer will not be responsible for construction means, methods, techniques, sequences or procedures, or for safety precautions and programs in connection with the Work, and will not be responsible for the Contractor's failure to carry out the Work in accordance with the Contract. Based on such observations and the Contractor's applications for payment, the Engineer will determine the amounts owing to the Contractor and will issue certificates for payment in amounts as provided elsewhere herein.

The Engineer may provide one or more full-time project representatives to assist the

Engineer in carrying out his responsibilities at the Work site. The duties, responsibilities and limitations of authority of the Engineer as the Authority's representative during construction as set forth herein will not be modified or extended without written consent of the Authority, the Contractor and the Engineer.

The Engineer will not be responsible for the acts or omissions of the Contractor, any Subcontractors, or any of their agents or employees, or any other persons performing any of the Work.

The Engineer shall decide the meaning and intent of any portion of the specifications, and of any plans or Drawings, where the same are found to be obscure or be in dispute; he shall have the right to correct any errors or omissions therein when such corrections are necessary to further the intent of said specifications, plans or Drawings; the action of such correction shall be effective from the date that the Engineer gives due notice thereof.

Any differences or conflicts which may arise between the Contractor and other contractors with the Authority in regard to their work shall be adjusted as determined by the Engineer.

Neither the Engineer's authority to act under this article or elsewhere in the Contract nor any decision made by the Engineer in good faith either to exercise or not to exercise such authority shall give rise to any duty or responsibility of the Engineer to the Contractor, any Subcontractor, any manufacturer, fabricator, supplier or distributor, or any of their agents or employees or any other person performing any of the Work.

Whenever in the Contract the terms "as ordered", "as directed", "as required", "as allowed", or terms of like effect or import are used, or the adjectives "reasonable", "suitable", "acceptable", "proper", or "satisfactory" or adjectives of like effect or import are used, to describe requirements, direction, review or judgement of the Engineer as to the Work, it is intended that such requirement, direction, review, or judgement will be solely to evaluate the Work for compliance with the Contract (unless there is a specific statement indicating otherwise). The use of any such term or adjective never indicates that the Engineer shall have authority to supervise or direct performance of the Work or authority to undertake responsibility contrary to the provisions of this General Condition.

GC-16. AUTHORITY'S RIGHT OF INSPECTION:

The Authority shall appoint or employ such engineers or inspectors as the Authority may deem proper to inspect the materials furnished and the work performed, and to determine whether said materials are furnished and work is performed in accordance with the Drawings and specifications therefor. The Contractor shall furnish all reasonable aid and assistance required by the Engineer, or by the Inspectors, for the proper inspection and examination of the Work and all parts thereof, even to the extent of uncovering or taking out portions of finished Work. Should the Work thus exposed or examined prove satisfactory, the uncovering or removing and the replacing of the covering or the making good of the parts removed shall be paid for by the Authority; however should the Work exposed or examined prove unsatisfactory, the uncovering,

taking out, replacing, and making good shall be at the expense of the Contractor.

Such inspection shall not relieve the Contractor of any obligation to perform said Work strictly in accordance with the Drawings and specifications or any modifications thereto as herein provided, and the Work not so constructed shall be removed and made good by the Contractor at his own expense, and free of all expense to the Authority, whenever so ordered by the Engineer, without reference to any previous oversight or error in inspection.

GC-17. SUSPENSION OF WORK ON NOTICE:

The Contractor shall delay or suspend the progress of the Work or any part thereof whenever he shall be so required by written order of the Authority or Engineer, and for such period of time as it or he shall require. Any such order of the Authority or Engineer shall not modify or invalidate in any way the provisions of this Contract.

GC-18. QUALITY OF WORKMANSHIP:

All workmanship shall be the best possible, both as to material and labor, that could be demanded by these Contract Documents, or if no specific description is given, it is understood that the best quality is required.

GC-19. SATURDAY, SUNDAY, HOLIDAY, AND NIGHT WORK:

No work shall be done between the hours of 7:00 p.m. and 7:00 a.m., or on Saturday, Sunday, or legal holidays without the written approval or permission of the Engineer in each case, except such work as may be necessary for the proper care, maintenance, and protection of work already done, or of equipment, or in the case of an emergency. Allowable working times within secured facilities may be adjusted by Engineer as necessary to facilitate established operational shift schedules.

GC-20. LAWS AND ORDINANCES:

The Contractor shall keep himself fully informed of all existing and current regulations of the City, county, state and national laws which in any way limit or control the actions or operations of those engaged upon the Work, or affecting the materials supplied to or by them. The Contractor shall at all times observe and comply with all applicable ordinances, laws, and regulations, and shall protect and indemnify the Authority and the Authority's employees officers and agents against any claims or liability arising from or based on any violations of the same.

The contractor certifies that it and all of its Subcontractors to be used in the performance of the Contract are in compliance with 25 O.S. Sec. 1313 and participate in the Status Verification System. The Status Verification System is defined in 25 O. S. Sec. 1312 and includes but is not limited to the free Employee Verification Program (E-Verify) available at www.dhs.gov/E-Verify.

The Contractor shall take the necessary actions to ensure its facilities are in compliance with the requirements of the Americans With Disabilities Act (ADA). It is understood that the program of the Contractor is not a program or activity of the City of Tulsa. The Contractor agrees that its program or activity will comply with the requirements of the

ADA. Any costs of such compliance will be the responsibility of the Contractor. Under no circumstances will Contractor conduct any activity, which it deems to not be in compliance with the ADA.

GC-21. TAXES AND PERMITS:

Unless otherwise specified in these Contract Documents, the Contractor shall pay all sales, use, and other taxes that are lawfully assessed against the Authority or Contractor in connection with the Work included in this Contract and shall obtain all licenses, permits, and inspections required for the Work. Contractor shall comply with all zoning ordinances of the City, as provided in the Tulsa Zoning Code, Title 42 Tulsa Revised Ordinances and conform with all zoning requirements established by the Tulsa Metropolitan Area Planning Commission and the Board of Adjustment. Contractor can call the Indian Nations Council of Governments (INCOG) at (918) 584-7526, to determine if any zoning requirements must be met.

GC-22. PROTECTION OF PROPERTY:

The protection of City, state, and government monuments, street signs, and other City property is of prime importance, and if the same be damaged, destroyed, or removed, they shall be repaired, replaced, or paid for by the Contractor.

Work occurring within secured facilities will require the Contractor to obtain City of Tulsa issued ID badges for all employees and subcontractors requiring facility gate access. The Contractor will be responsible for all coordination with City Security as necessary to process background checks and issue badges. The City of Tulsa has the right to deny access to any individual based on evaluation of background check.

GC-23. PATENT RIGHTS:

All fees for any patented invention, article, or arrangement that is based upon, or in any manner connected with the construction, erection, or maintenance of the Work or any part thereof embraced in the Contract and these specifications, shall be included in the price stipulated in the Contract for said Work. The Contractor shall protect and hold harmless the Tulsa Metropolitan Utility Authority, against any and all demands of such fees or claims.

GC-24. DEFENSE OF SUITS:

In case any action at law or suit in equity is brought against the Authority or any employee, officer or agent thereof, for or on account of the failure, omission or neglect of the Contractor to do and perform any of the covenants, acts, matters, or things required by this Contract to be done or performed, or for injury or damage caused by negligence or willful act of the Contractor or his Subcontractors or his or their agents, or in connection with any claim or claims based on the lawful demands of Subcontractors, workmen, materialmen, or suppliers of machinery and parts thereof, equipment, power tools, and supplies incurred in the fulfillment of this Contract, the Contractor shall indemnify and save harmless the Authority and its employees, officers and agents, and the Engineer and any employees, officers and agents thereof, of and from all losses, damages, costs, expenses, judgements, or decrees whatsoever arising out of such action or suit that may be brought, without requiring said parties to give any notice

thereof.

The Authority may suspend payments of any sum due or to become due for work done on this Contract until such claims, suits, actions, or proceedings are final and liability has been determined. The amount of such damages or liability shall be deducted from sums due or to become due on this Contract. The sums mentioned above will be retained by the Authority until the Contractor furnishes evidence that satisfactory settlement has been made. Any action taken by the Authority shall not excuse the Contractor for failure to perform this Contract or bar the Authority from legal action to recover from the Contractor the amount of damages or liability suffered in excess of the amount retained.

The Contractor shall furnish the Authority with satisfactory evidence, upon demand, that all persons who have done work on the Contract or furnished materials for the Contract have been paid in full. If such evidence is not furnished, the amount necessary to pay the lawful claims may be retained until such evidence is furnished, or if such evidence is not furnished, the Authority may apply any sums retained to valid claims and charge the amounts disbursed, including the costs of any action that may be necessary to prove or disprove the claims against the Contractor.

GC-25. REMOVAL OF CONDEMNED MATERIALS AND STRUCTURES:

The Contractor shall remove from the site of the Work, without delay, all rejected and condemned materials or structures of any kind brought to or incorporated in the Work, and upon his failure to do so, or to make satisfactory progress in so doing, within forty-eight (48) hours after the service of a written notice from the Engineer ordering such removal, the condemned material or structures may be removed by the Authority and the cost of such removal be taken out of the money that may be due or may become due the Contractor by virtue of this Contract. No such rejected or condemned material shall again be offered for use by the Contractor under this or any other Contract under this project.

GC-26. EXTRA WORK:

If a modification increases the amount of the Work, and the added Work or any part thereof is of a type and character which can properly and fairly be classified under one or more Unit Price items of the Bid Form, then the added Work or part thereof shall be paid for according to the amount actually done and at the applicable Unit Price. Otherwise, such work shall be paid for as hereafter provided.

Claims for extra work will not be paid unless the Work covered by such claims was authorized in writing by the Authority. The Contractor shall not have the right to take action in court to recover for extra work unless the claim is based upon a written order from the Authority. Payments for extra Work will be based on agreed lump sums or on agreed Unit Prices whenever the Authority and the Contractor agree upon such prices before the extra Work is started.

For the purpose of determining whether proposed extra work will be authorized, or for determining the payment method for extra work, the Contractor shall submit to the

Engineer, upon request, a detailed cost estimate for proposed extra work. The estimate shall show itemized quantities and charges for all elements of direct cost.

The cost shall include only those extra costs for labor and materials expended in direct performance of the extra work and may include:

- (a) **Labor.** For all labor and foremen in direct charge of the specific operations, the Contractor shall receive the rate of wage (or scale) agreed upon in writing before beginning work for each and every hour that said labor and foremen are actually engaged in such work. An amount equal to fifteen (15) percent of the sum of the above items will also be paid the Contractor.
- (b) **Bond, Insurance, and Tax.** For property damage, liability, and workmen's compensation insurance premiums, unemployment insurance contributions and social security taxes on the force account work, the Contractor shall receive the actual cost, to which cost no percentage will be added. The Contractor shall furnish satisfactory evidence of the rate or rates paid for such bond, insurance, and tax.
- (c) **Materials.** For materials accepted by the Engineer and used, the Contractor shall receive the actual cost of such materials delivered on the Work site, including transportation charges paid by him (exclusive of machinery rentals as hereinafter set forth), to which cost ten (10) percent will be added.
- (d) **Equipment.** For any machinery or special equipment (other than small tools) including fuel, lubricants and transportation costs, the use of which has been authorized by the Engineer, the Contractor shall receive the rental rates agreed upon in writing before such work is begun for the actual time that such equipment is in operations on the Work, as provided in Subsection 109.01(a), to which rental sum no percentage will be added.
- (e) **Miscellaneous.** No additional allowance will be made for general superintendence, the use of small tools, or other costs for which no specific allowance is herein provided.

The form on which field cost records are kept, the construction methods and the type and quantity of equipment used shall be submitted to the Engineer for approval.

Construction equipment which the Contractor has on the Work site and which is of a type and size suitable for use in performing the extra Work shall be used. The hourly rental charges for equipment, including all insurance, taxes, fuel, and operating costs, shall not exceed twelve (12) percent of the latest applicable Associated Equipment Distributors published monthly rental rates and shall apply to only the actual time the equipment is used in performing the extra Work.

When extra Work requires the use of equipment, which the Contractor does not have on the work site, the Contractor shall obtain the approval of the Engineer before renting or

otherwise acquiring additional equipment. The rental charges for the additional equipment shall not exceed the latest applicable Associated Equipment Distributors published rental rates.

The Contractor shall file with the Engineer, certified lists in duplicate, of any equipment and the schedule of pay rates for common and semi-skilled labor and operators of various classes which are intended to be used in performing the Work covered by this Contract. These rates shall be subject to the review of the Engineer. This information will be used by the Engineer for computation of extra work as mentioned above, however, if the Contractor fails to file these lists with the Engineer prior to starting any Work covered by this Contract, then the Engineer's computation shall be based on average wages and rates paid on Authority work.

GC-27. PAYMENT FOR CONTRACTOR'S PLANT AND MISCELLANEOUS TEMPORARY WORK:

For providing plant, tools, and equipment, and for furnishing, erecting, maintaining, and removing scaffolding and construction plant, construction roads, camps, sanitary conveniences, temporary water supply, trestles, dewatering and other temporary works, the Contractor shall receive no direct payment, but compensation for them shall be considered as having been included in the prices stipulated for the appropriate items.

GC-28. BASIS OF PAYMENT FOR ITEMS OF WORK:

The Contractor shall be paid for all Work performed under the Contract based on the Engineer's computations of as-built quantities and the Contractor's Unit Price or Lump Sum bid per item. This payment shall be full compensation for furnishing all supplies, materials, tools, equipment, transportation, and labor required to do the Work; for all loss or damage, because of the nature of the work, the action of the elements or any unforeseen obstruction or difficulty which may be encountered in the performance of the Work, and for which payment is not specifically provided; for all expense incurred by or because of any suspension or discontinuance of all or any part of the Work; and for faithfully completing the Contract according to the Drawings and specifications and requirements of the Engineer.

GC-29. PAYMENTS: (1) Partial:

If the work is progressing in good and workmanlike manner and if the Contractor is faithfully carrying out the terms of this Contract, approximate estimates of the work done shall be made by the Engineers between the first and fifteenth of each calendar month, including labor actually performed and supplies or materials actually used or incorporated in the Work, and an allowance will be made for acceptable materials satisfactorily delivered, stored and secured on the site of the Work in such amount as can be incorporated in the Work within a reasonable time. The Authority shall have a lien as owner on any materials stored on the site of the Work.

Each partial estimate for payment shall contain or have attached an affidavit in the form found in this book of specifications, as required by law.

The Contractor shall submit with each partial pay estimate a complete list of vendors

and suppliers with itemized purchases and invoices from each vendor. Each list shall contain the name of the Contractor or Subcontractor ordering the materials or supplies, and the specific use or placement of each of the materials purchased by the Tulsa Metropolitan Utility Authority for this project in accordance with Article IIB of the Contract. At the direction of the Contractor, the Tulsa Metropolitan Utility Authority will withhold retainage in the amount of 5% on materials and supplies to be purchased under the terms of this Contract. If fuels are purchased, they shall be limited to dyed diesel fuel and/or kerosene for non-highway use. No unleaded gasoline will be permitted.

Each month that work is performed for which payment is due, the Contractor shall submit to the Engineer an application for such payment, provided said payment is not less than \$1,000.00, and, if required, receipts or other vouchers from Subcontractors showing his payments to them shall be submitted.

Each estimate shall be of the approximate value of all work performed and materials in place or delivered to the Work site, determined as aforesaid from the beginning of this contract to the date fixed for the current estimate, from which shall be deducted five percent (5%), or a lesser amount approved by the Authority, and, in addition thereto, all previous payments and all other sums withheld under the foregoing provisions of this Contract, the remainder to become due and payable; after the estimate has been reviewed and signed by the Engineer and the Authority, shall pay the estimate in the regular manner in the amount determined as due unless it shall be known by the Authority that there is good reason under the terms of this Contract for withholding same.

The Contractor may withdraw any part or the whole of the amount which has been retained from partial payment to the Contractor pursuant to the terms of Contract, upon depositing with or delivery to the City:

- (1) United States Treasury Bonds, United States Treasury Notes, United States Treasury bills, or
- (2) General Obligation Bonds of the State of Oklahoma, or
- (3) Certificates of Deposit from a state or national bank having its principal office in the State of Oklahoma.

No retained amount shall be withdrawn which would represent an amount in excess of the market value of the securities at the time of deposit or of the par value of such securities, whichever is lower.

All partial estimates are subject to correction in the final estimate.

(2) Final Payment:

When this contract, in the opinion of the Engineer, shall be completely performed on the part of the Contractor, the Engineer shall proceed with all reasonable diligence to

measure up the Work and shall make out the final estimate for the same, and shall, except for cause herein specified, give to the Contractor, within thirty (30) days after receiving said certificate, an order on the Authority for the balance found to be due, excepting therefrom such sum or sums as may be lawfully retained under any of the provisions of the Contract; PROVIDED, that nothing herein contained shall be construed to affect the rights of the Authority hereby reserved to reject the whole or any portion of the aforesaid Work should the said estimate and certificate be found or known to be inconsistent with the terms of this Contract or otherwise improperly given; PROVIDED, that if after the work hereunder has been accepted and final payment made, it shall be discovered that any part of the Contract has not been fully performed or has been done in an improper or faulty manner, the Contractor shall immediately remedy such defect, or, in case of neglect to do so within a reasonable time after notice thereof, shall be liable for and shall pay to the Authority the cost of remedying such defect or a sum equal to the damages sustained thereby, as the Authority shall elect and the acceptance of and final payment for the Work shall be no bar to suit on any bond against any principal or principals, or Surety or Sureties, or both, given for the due performance of the Contract, or for the recovery of such cost or the equivalent of such damage.

The Authority will pay to the Contractor interest at the rate of three-fourths percent (3/4%) per month on the final payment due the Contractor. For lump sum contracts, the interest shall commence thirty (30) days after the Work under the Contract has been completed and accepted and all required material certifications and other documentation required by the Contract have been furnished the Authority by the Contractor, and shall run until the date when the final payment or estimate is tendered to the Contractor. For contracts bid by Unit Prices, the interest will commence sixty (60) days after the above conditions are satisfied. When contract quantities or the final payment amount is in dispute, the interest-bearing period will be suspended until the conclusion and settlement of the dispute.

GC-30. CONTRACTOR REIMBURSEMENT FOR SURETY BOND:

For contracts of \$1,000,000.00 or more, the Contractor may receive reimbursement for the cost of the surety bonds after issuance of a work order. To receive reimbursement, the Contractor shall submit a standard partial payment form and affidavit, and a copy of the surety bond invoice. The final partial pay estimate will be reduced by the amount paid for surety bond reimbursement.

GC-31. RELEASE OF LIABILITY AND ACCEPTANCE:

The acceptance by the Contractor of the final payment shall operate as, and shall be a release to the Authority and every employee, officers and agents thereof, from all claims and liability to the Contractor for anything done or furnished for or relating to the Work, or for any act or neglect of the Authority or of any person relating to or affecting the Work, and, following such acceptance, no person, firm, or corporation other than the signer of this Contract as Contractor, will have any interest hereunder, and no claim shall be made or be valid, and neither the Authority nor any employees or agent thereof shall be liable or be held to pay any money, except as herein provided.

It shall be the duty of the Engineer to determine when the Work is completed and the Contract fulfilled, and to recommend its acceptance by the Authority. The Work herein specified to be performed shall not be considered finally accepted until all the Work has been accepted by the Authority.

GC-32. RIGHT OF AUTHORITY TO TERMINATE CONTRACT:

If the Work to be done under this Contract shall be abandoned by the Contractor, or if this Contract shall be assigned by him otherwise than as herein provided, or if the Contractor should be adjudged bankrupt, or if a general assignment of his assets be made for the benefit of his creditors, or if a receiver should be appointed for the Contractor or any of his property; or if at any time the Engineer shall certify in writing to the Authority that the performance of the Work under this Contract is being unnecessarily delayed, or that the Contractor is executing the same in bad faith or otherwise not in accordance with the terms of the Contract; or if the work be not substantially completed within the time named for its completion, or within the time to which such completion date may be extended; then the Authority may serve written notice upon the Contractor and his Surety of Authority's intention to terminate this Contract, and unless, within five (5) days after service of such notice upon the Contractor, a satisfactory arrangement is made for the continuance of the Contract, this Contract shall cease and terminate. In the event of such termination, the Authority shall immediately serve notice upon the Surety and Contractor, and the Surety shall have the right to take over and complete the Work, provided, however, that if the Surety does not commence performance thereof within fifteen (15) days from the date of said notice of termination, the Authority may take over the Work and perform same to completion, by Contract or otherwise, for the account and at the expense of the Contractor, and the Contractor, and his Surety, shall be liable to the Authority for any and all excess cost sustained by the Authority by reason of such performance and completion. In such event the Authority may take possession of and utilize in completing the Work, all such materials, equipment, tools, and plant as may be on the site of the Work and necessary therefor. The Contractor shall not receive any other payment under the Contract until said Work is wholly finished, at which time, if the unpaid balance of the amount to be paid under the Contract shall exceed the expense incurred by the Authority in finishing the Work as aforesaid, the amount of the excess shall be paid to the Contractor, but if such expense shall exceed the unpaid balance, the Contractor shall pay the difference to the Authority.

GC-33. ADMINISTRATIVE COSTS AND FEES:

Cash Improvements - In the event the improvements are to be paid for in cash: the costs and fees for publication, engineering, filing, recording, abstracting, acquisition of easements, flushings, and pipe testing, shall be paid by the Authority unless otherwise provided for in these Contract Documents.

Assessment Improvements: In the event the improvements are to be paid for by the issuance of special assessment bonds, the costs and fees for publication, engineering, filing, recording, abstracting, acquisition of easements, flushing, pipe testing, and other authorized costs shall be added to the contract price and paid for in the same manner as the other Work included in this Contract. The Contractor shall pay the Authority the

amount of said charges before the execution and delivery of the special assessment bonds or other payments. If the Contractor fails, neglects, or refuses to pay said charges within thirty (30) days after the bonds are ready for delivery, he shall pay the Authority interest at the rate of seven percent (7%) per annum and shall be liable for same in a civil suit. The Contractor shall pay the pipe testing fees directly to the testing laboratory.

GC-34. PAYMENT OR ACCEPTANCE NOT A WAIVER BY AUTHORITY:

Neither acceptance by the Authority or the Engineer or any employee of either nor any order by Authority for the payment of money, or the payment thereof, nor any taking of possession by Authority, nor the granting of any extension of time, shall operate as a waiver of any rights or powers of the Authority hereunder, and in the event that after the Work hereunder has been accepted and final payment made, it should be discovered that any part of this Contract has not been fully performed, or has been done in a faulty or improper manner, the Contractor shall immediately remedy such defect, or in the event of neglect to do so within a reasonable time after notice thereof, shall be liable for and shall pay to Authority the cost of remedying such defect, or a sum equal to the damage caused thereby, as Authority may elect. The acceptance of the Work or final payment therefor shall be no bar to suit against the Contractor or Surety, or both.

GC-35. CONTRACTOR'S OBLIGATION AFTER ACCEPTANCE:

Contractor further agrees, without cost other than is specially provided for in this Contract, at any and all times during one (1) year next following the completion and final acceptance of the Work embraced in this Contract, without notice from Authority, to refill all trenches or ditches that may sink or settle; and to repair all breaks and failures that may occur in the construction work due to defective material or workmanship; and to indemnify, save harmless and defend the Authority from any and all suits and actions of every description brought against Authority for, or on account of injuries or damages alleged to have been received or sustained by any party or parties by reasons of, or arising out of the failure of Contractor to refill all trenches and ditches and to repair all breaks or failures of said construction work, which said injuries or damages are alleged to have been received or incurred within one (1) year from the final acceptance of the Work hereunder, and to pay any and all judgements that might be rendered against Authority in any suits and actions, together with such expenses or attorney's fees expended or incurred by Authority in the defense thereof, and Contractor hereby expressly waives any notice that might by law be required to be given to them by Authority of any defect, break, settling, or failure or of any other condition that might be the cause of injury or damage to any person on account of which a claim or suit might be made or filed against Authority, or a judgement taken for damages against Authority. It is expressly agreed that the acceptance of the Work by Authority shall constitute no bar against any person injured or damaged by the failure of the Contractor to perform all of his covenants and agreements hereunder from maintaining an action against the Contractor, or against Authority from enforcing its rights against the Contractor hereunder.

GC-36. NOTICES:

Any notices or other communications hereunder may be given to Contractor at the

address listed in the Proposal, to the Surety at the office of the Attorney-in-Fact signing the bond or at Surety's home office address on file with the Insurance Commissioner of the State of Oklahoma, and to Authority in care of the City of Tulsa's Director of Public Works, or at such other place as may be designated in writing. The delivery at such address, or depositing in any mailbox regularly maintained by the Post Office, of any notice, letter, or other communication to the Contractor, shall be deemed sufficient service thereof, and the date of said service shall be the date of such delivery or mailing.

GC-37. RELATION TO OTHER CONTRACTORS:

Nothing herein contained and nothing marked upon the Drawings shall be interpreted as giving the Contractor exclusive occupancy of the territory or right-of-way provided. The Authority and its employees, officers, and agents for any just purpose, and other contractors of the Authority for any purpose required by their respective contracts, may enter upon or cross this territory or occupy portions of it or take materials therefrom as directed or permitted. When two or more contracts are being executed at one time on the same or adjacent land in such manner that the work on one contract may interfere with the work on another, the Engineers shall decide which contractor shall cease work and which shall continue, or whether the work on both contracts shall progress at the same time and in what manner. When the territory of one contract is the necessary or convenient means of access for the transportation or movement of men, machines, or appliances for the execution of another contract, such privilege of access or any other reasonable privilege may be granted by the Engineers to the contractor desiring it, to the extent, amount, in the manner and at the time permitted. Any decision regarding the method or time of conducting the work or the use of the territory shall not be made the basis of claims for delay or damage except as otherwise stipulated. The Contractor shall not cause any unnecessary hindrance or delay to any other contractors on the premises, and shall bear all damages done to the work of such other contractors by him or by his employees.

GC-38. PARTIAL OCCUPANCY AND USE:

The Authority, upon advance written notification to the Contractor, shall have the right to occupy and use any completed or partially completed portions of the Work site when such occupancy and use are in the Authority's best interest, notwithstanding completion of the entire project.

Such partial occupancy and use shall be upon the following terms:

- a. The Engineer shall make an inspection of the portion or portions of the Work concerned, and report to the Authority his findings as to the acceptability and completeness of the Work. The Engineer's report shall include a list of items to be completed or corrected before final payment.
- b. The Authority, upon acceptance of the Engineer's report, shall give written notice to the Contractor of the Authority's intention to occupy

and use said portions of the Work site. The Authority's notice shall include a copy of the Engineer's report, shall clearly identify the portions of the Work site to be occupied and used, and shall establish the date of said occupancy and use.

- c. From the date thus established, the Authority shall assume all responsibilities for operation, maintenance, and the furnishing of water, gas, and electrical power for the portions of the Work site thus occupied and used. The Authority shall have the right to exclude the Contractor from those portions of the Work site but shall provide the Contractor reasonable access to complete or correct necessary items of Work.
- d. The one year guarantee required by the General Conditions shall not begin until completion and final acceptance of the entire project. If, before final acceptance, the Contractor completes any mechanical or electrical equipment such as pumps, blowers, process equipment, instrumentation, controls, metering equipment, heating, and ventilation equipment and similar items having movable or operable components, the Contractor may then request partial acceptance of each completed equipment system. In response, the Engineer will perform a final inspection of each system and determine if all specifications are satisfied, including but not limited to start-up conditions, performance criteria, control systems, training, and final operation manuals (O & M's). Once found to be complete, ready for operation, and isolated from all remaining work, the Engineer will provide Contractor with written notice of partial acceptance and the start date for the one year guarantee required by the General Conditions.
- e. Occupancy or use of any space in the Work site shall not constitute acceptance of Work not performed in accordance with the Contract, nor relieve the Contractor of liability to perform any Work required by the Contract but not completed at the time of said occupancy and use.
- f. The Contractor shall not be held responsible for normal wear and tear or damage resulting from said occupancy, except to the extent that such damage is covered by the one-year guarantee.
- g. The partial occupancy and use of any portions of the Work site by the Authority shall not constitute grounds for claims by the Contractor for release of any amounts retained from payments under the provisions of the Contract. The retained amounts will not be due until completion of the entire project for final acceptance and final payment, as set forth in the General Conditions.

SPECIAL
PROVISIONS

SPECIAL PROVISION
SUPPLEMENTAL CONTRACT REQUIREMENTS
PROJECT NO. TMUA ES-2025-SOM5
SANITARY SEWER REHAB & REPAIRS

1. SCOPE: Contractor shall provide all labor, tools, equipment, and materials to perform the work necessary to complete the Sanitary Sewer Rehab & Repairs as designated on the Plan Sheet Index. Any deviation from the methods described on the Plan Sheet Index shall be approved in advance by the Authority. All work on the project must be completed within 365 days.
2. Successful Contractor shall return fully executed contract documents (including bonds and insurance) to the City of Tulsa, Contract Administration Section, 9319 E. 42 St. N. within two weeks after the bid award is approved.
3. The contractor shall submit a yearly and monthly work schedule showing the order in which the work shall be accomplished. This schedule shall be the basis for obtaining permission for individual homeowners and for the Authority's representative to assist, if needed, and for progress projections. A weekly email needs to be sent notifying the Authority's representative of the contractor's work location.
4. The contractor will notify all homeowners and businesses in the area at least 48 hours prior to commencing any operations using a written door hanger notice with the project number and Sewer Operations and Maintenance 24-hour number 918-586-6984. The door hanger notices must be submitted with the submittals for approval.
5. Contractor shall complete SOM Sanitary Repair Summary for each repair performed.
6. The Contractor shall use matching pipe for point repair unless otherwise designated on the Plan Sheet Index.
7. Bid item 2 Digital Photographic Documentation - Contractor must take a minimum of six (6) digital photos before work begins at the jobsite and a minimum of six (6) digital photos after the job is completed.
8. Bid items 4 Manhole Replacement - Contractor shall use new 30" GMI composite manhole lid and castings and shall be constructed with a 30" opening. Contractor shall use Cretex Pro-Ring round manhole adjustment rings instead of concrete raising rings on any manhole adjustments or installations. The Pro-Rings shall be sealed to the concrete section of the manhole and to the manhole casting with Cretex M-1 Adhesive. If multiple Pro-Rings are used, Contractor shall seal between each ring as well. Angled rings shall be used to match the incline of the surrounding area. Any deviation using Cretex Pro-Ring adjustment rings must be approved in advance by the Authority's Representative.

9. Bid item 6 Lamphole Replacement Per Spec. No. 417 - The replacement lamphole material shall be PVC pipe or DIP pipe, as directed by the engineer, with the following exception: when the lamphole connects to pipe that is being Sliplined or Pipeburst with Polyethylene pipe, the hole shall also be made of Polyethylene pipe and fused to the Slipline or Pipeburst PE pipe.
10. Bid items 8 & 10 Service connections on Slipline and Pipeburst - All service connections on Polyethylene (P.E.) pipe will be connected utilizing electrofusion saddles. Electrofusion couplings will be utilized to connect joints of Polyethylene pipe to replace the host pipe. Internal fusion beads must be removed from Polyethylene pipe during installation.
11. Bid items 9 Pipeburst - The contractor shall utilize Polyethylene (P.E.) pipe to replace the host pipe.
12. Bid Item 11 Open-cut - Contractor shall utilize SDR-26 PVC pipe to replace the host pipe.
13. Bid item 13 Excessive depth - A unit price which shall cover the entire cost of each additional foot of vertical depth of repair job that exceeds 15 feet.
14. Bid item 14 is Obstruction Removal - Obstruction removal before Pipeburst or Slipline shall only apply to obstructions that prevent the Pipeburst or Slipline operation and removal of sags designated by the Authority.
15. Bid item 15 Dewatering - Contractor may be paid for dewatering operations per dewatering pump used in well-point situations as approved in advance by Authority's representative. The bid item will not be paid for sump pump or trash pump usage.
16. Bid item 16 External Drop Replacement - External Drop Replacement on Open-cut repairs shall be performed in accordance with standard specification. External Drop Replacement on Slipline and Pipeburst repairs must be excavated and replaced with new pipe. On Slipline and Pipeburst repairs performed using HDPE pipe, Contractor shall electro-fuse a 90-degree bend, a fused "tee" and HDPE pipe for the drop replacement. All materials shall be made of the same ID (inside diameter) HDPE pipe as used for the repair. On Slipline and Pipeburst repairs performed using D.I.P. pipe, the external drop shall be replaced with a D.I.P. drop. Per standard detail No. 416, 417, 418 and 419.
17. Internal Drop Installation - Internal Drops may only be installed by special approval of Authority in accordance with approved standard and will be from Specialty Work Allowance.
18. Bid item 17 Specialty Work Allowance - Allowance in the amount of \$10,000 for specialty work that may be required by the Engineer. Contractor shall provide cost estimate for Engineer approval prior to performing specialty work. This will be for unforeseen items including but not limited to installing piers or otherwise supporting a structure during excavation; specialty landscaping items; specialty decking protection or restoration; or any other non-standard items during a sewer repair. Contractor to furnish a schedule of costs for these items on sites requiring such items.

19. Contractors with "C" certification from the City of Tulsa may choose to perform pavement restoration instead of utilizing the paving cut process. For pavement restoration following sewer work, contractor shall utilize flowable fill for backfill 2' (two feet) below the pavement. Contractors without "C" certification shall be required to obtain a paving cut permit and pay for both paving cut permit and the paving cut. The cost of the paving cut permit, and restoration is considered incidental and should be included in the cost of the repair.
20. The contractor shall complete a repair work order for each location on the City designated form that details the work performed, materials used and specific service line reconnection information. The repair work order shall be submitted immediately after the repair is complete.
21. All water, sanitary sewer and storm sewer manhole castings, lids, frames, curb hoods, grates, hydrants, valves and any other fittings removed as part of any construction project are the property of the City of Tulsa. Contractor will not take ownership.

All sanitary and storm sewer manhole castings and lids that are in the street and are disturbed by the Contractor shall be delivered to the Sewer Operations Maintenance base at 9319 E. 42nd St. North and placed in the metal recycle bin in the stockroom area between the hours of 7:30 a.m. and 3:00 p.m., Monday through Friday. Phone: 918-586-6994

All hydrants, valves and other fittings from abandoned water mains shall be salvaged and delivered by the Contractor to the south yard at 2317 South Jackson Ave. Contractor will coordinate the return of such items with the south yard personnel at 918-596-9401.

MASTER REHAB SCHEDULE
ES2025SOM5

Sheet	Area	Page	UP MH	DN MH	Address	Special Instructions - Method of repair may change based on site conditions	Pipe Size	Depth	Pipe Type	Est. Repair Footage	Drop	Taps
1	7	281	33	32	3753 N Lansing Pl	Pipeburst	8	5'-6"	VCP	263	Y	4
1	7	281	33		3753 N Lansing Pl	Complete MH Replacement		5'				
2	7	281	83	82	411 E 40 Pl N	Opencut	8	4'-5"	VCP	301	N	4
2	7	281	83		411 E 40 Pl N	Complete MH Replacement		5'				
2	7	281	82		433 E 40 Pl N	Complete MH Replacement		4'				
3	7	281	92	91	575 E 40 St N	Opencut	8	5'-11"	VCP	73	Y	1
3	7	281	92		575 E 40 St N	Change LH to MH		5'				
3	7	281	92		578 E 40 Pl N	Complete MH Replacement w/drop		11'				
4	7	218	134	133	3362 N Garrison Ave	Pipeburst	8	5'-7"	VCP	360	N	7
5	10	432	135	134	4976 N Trenton Ave	Pipeburst	8	6'-7"	VCP	300	N	11
5	10	432	136	135	4675 N St Louis Ave	Silipine	8	6'-7"	VCP	65	N	2
5	10	432	136		4675 N St Louis Ave	Change LH to MH		7'				
6	10	432	157	154	1619 E 49 St N	Pipeburst	8	4'-10"	VCP	269	N	2
6	10	432	157		1619 E 49 St N	Complete MH Replacement		4'				
6	10	432	158	157	4916 N Trenton Ave	Pipeburst	8	4'-9"	VCP	320	N	4
7	10	432	164	163	1574 E 51 St N	Silipine	8	5'-6"	VCP	70	N	2
7	10	432	164		1574 E 51 St N	Change LH to MH		5'				
6	10	432	166	157	4929 N Trenton Ave	Pipeburst	8	4'-6"	VCP	358	N	5
8	10	432	195	194	1537 E 48 St N	Pipeburst	8	6'-7"	VCP	140	N	0
8	10	432	196	195	1570 E 48 Pl N	Silipine	8	6'-8"	VCP	90	N	4
8	10	432	196		1570 E 48 Pl N	Change LH to MH		8'				
9	22	715	132	133	6396 N Cheyenne Ave	Opencut	8	5'-8"	VCP	65	N	2
9	22	715	132		6396 N Cheyenne Ave	Change LH to MH		5'				
10	67	138	13	12	3814 S Wheeling Ave	Pipeburst	8	6'-7"	VCP	232	N	5
11	89	174	41	40	10700 E Independence St	Pipeburst	8	7'-16"	VCP	240	N	0
12	90	12	776	347	1204 S Gary Pl	Pipeburst	8	8'-10"	VCP	125	Y	0
12	90	12	776		1204 S Gary Pl	Complete MH Replacement		8'				
13	93	28	309	308	4746 E 7 St	Pipeburst	8	14'-15'	VCP	165	N	0

MANHOLE REHAB SCHEDULE
 ES2025SOM5

Sheet	Area	Page	MH	Depth	Add Vert	MH Replacement 4' I.D.	Standard 4' Diameter Manhole	Abandon Manhole	Notes
1	7	281	33	5'		X			
2	7	281	83	5'		X			
2	7	281	82	4'		X			
3	7	281	92	5'		X			
3	7	281	91	11'	5	X			
5	10	432	136	7'	1	X			
6	10	432	157	4'		X			
7	10	432	164	5'		X			
8	10	432	196	8'	2	X			
9	22	715	132	5'		X			
12	90	12	776	8'	2	X			

PIPE REHAB SCHEDULE
 ES2025SOM5

Sheet	Area	Page	UP MH	DN MH	Pipe Size	Depth	Pipe Type	8" Slipline	8" Pipeburst	8" Open Cut	8" Opencut Installation	Abandon 8" Dia Sanitary Sewer Pipe	External Drop	Service Reconnection	Pre & Post Inspection
1	7	281	33	32	8	5'-6"	VCP		X				Y	4	263
2	7	281	83	82	8	4'-5"	VCP			X			N	4	301
3	7	281	92	91	8	5'-11"	VCP			X			Y	1	73
4	7	218	134	133	8	5'-7"	VCP		X				N	7	360
5	10	432	135	134	8	6'-7"	VCP		X				N	11	300
5	10	432	136	135	8	6'-7"	VCP	X					N	2	65
6	10	432	157	154	8	4'-10"	VCP		X				N	2	269
6	10	432	158	157	8	4'-9"	VCP		X				N	4	320
7	10	432	164	163	8	5'-6"	VCP	X					N	2	70
6	10	432	166	157	8	4'-6"	VCP		X				N	5	358
8	10	432	195	194	8	6'-7"	VCP		X				N	0	140
8	10	432	196	195	8	6'-8"	VCP	X					N	4	90
9	22	715	132	133	8	5'-8"	VCP			X			N	2	65
10	67	138	13	12	8	6'-7"	VCP		X				N	0	232
11	89	174	41	40	8	7'-16"	VCP		X				N	0	240
12	90	12	776	347	8	8'-10"	VCP		X				Y	0	125
13	93	28	309	308	8	14'-15"	VCP		X				N	0	165



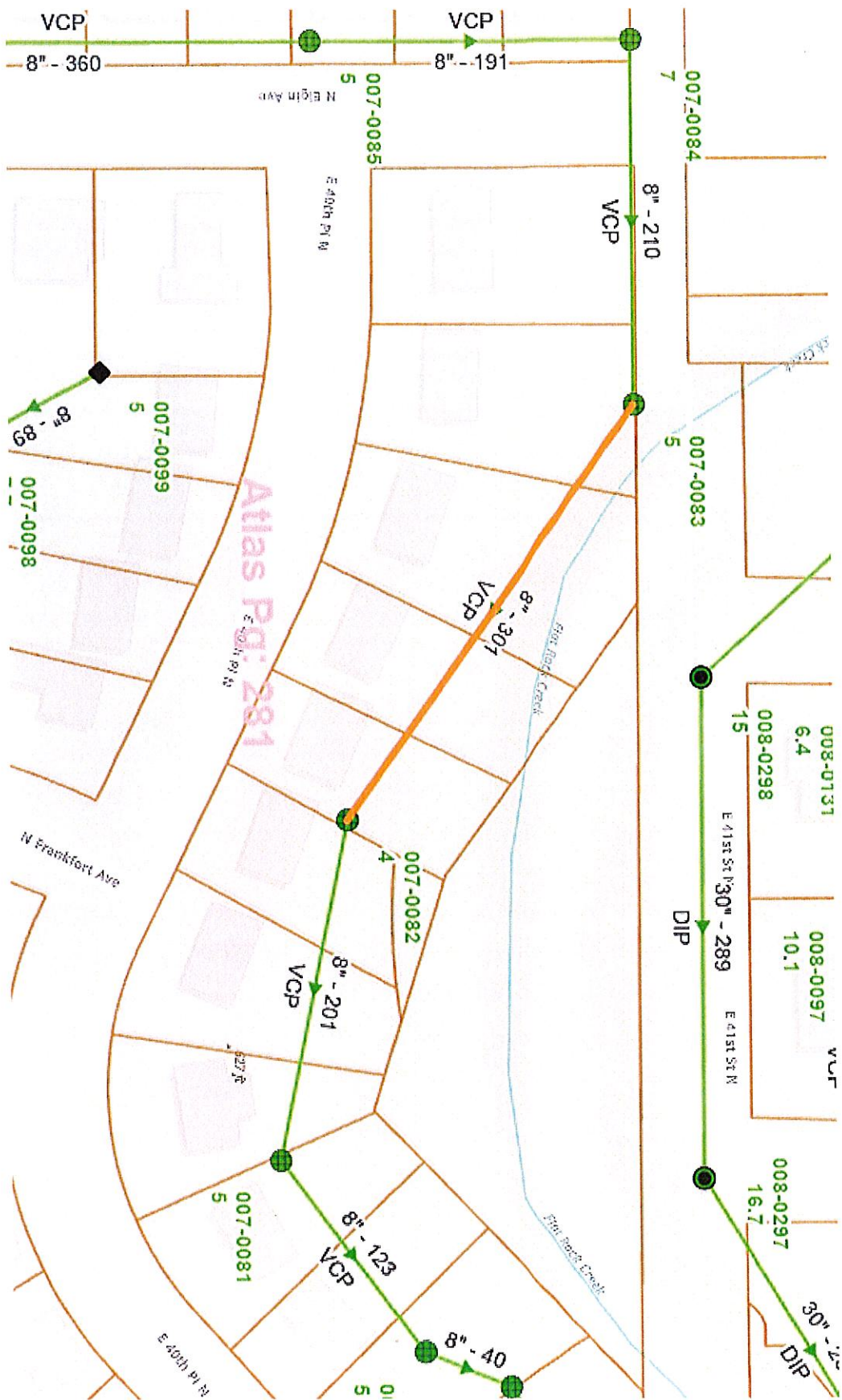

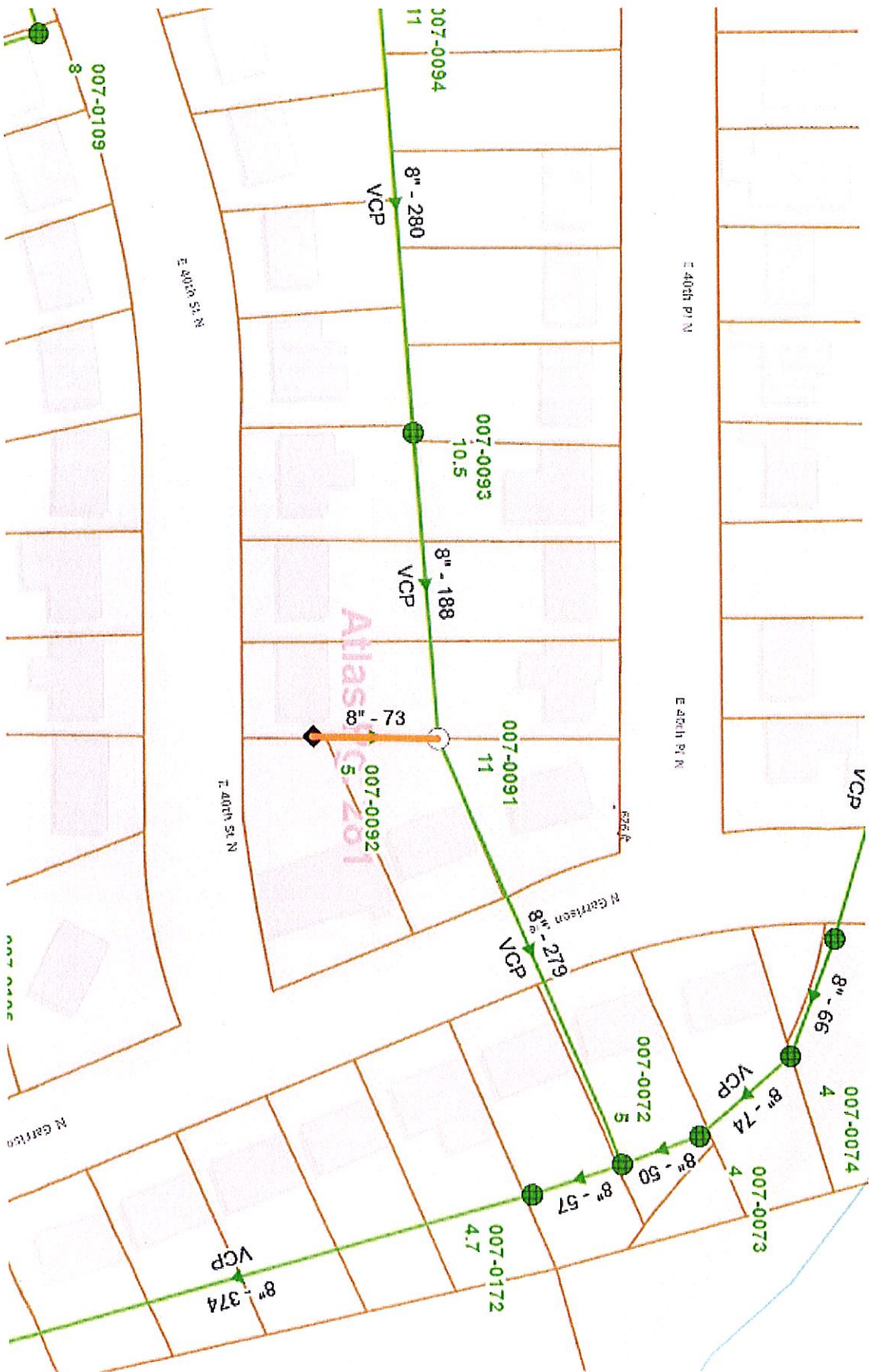

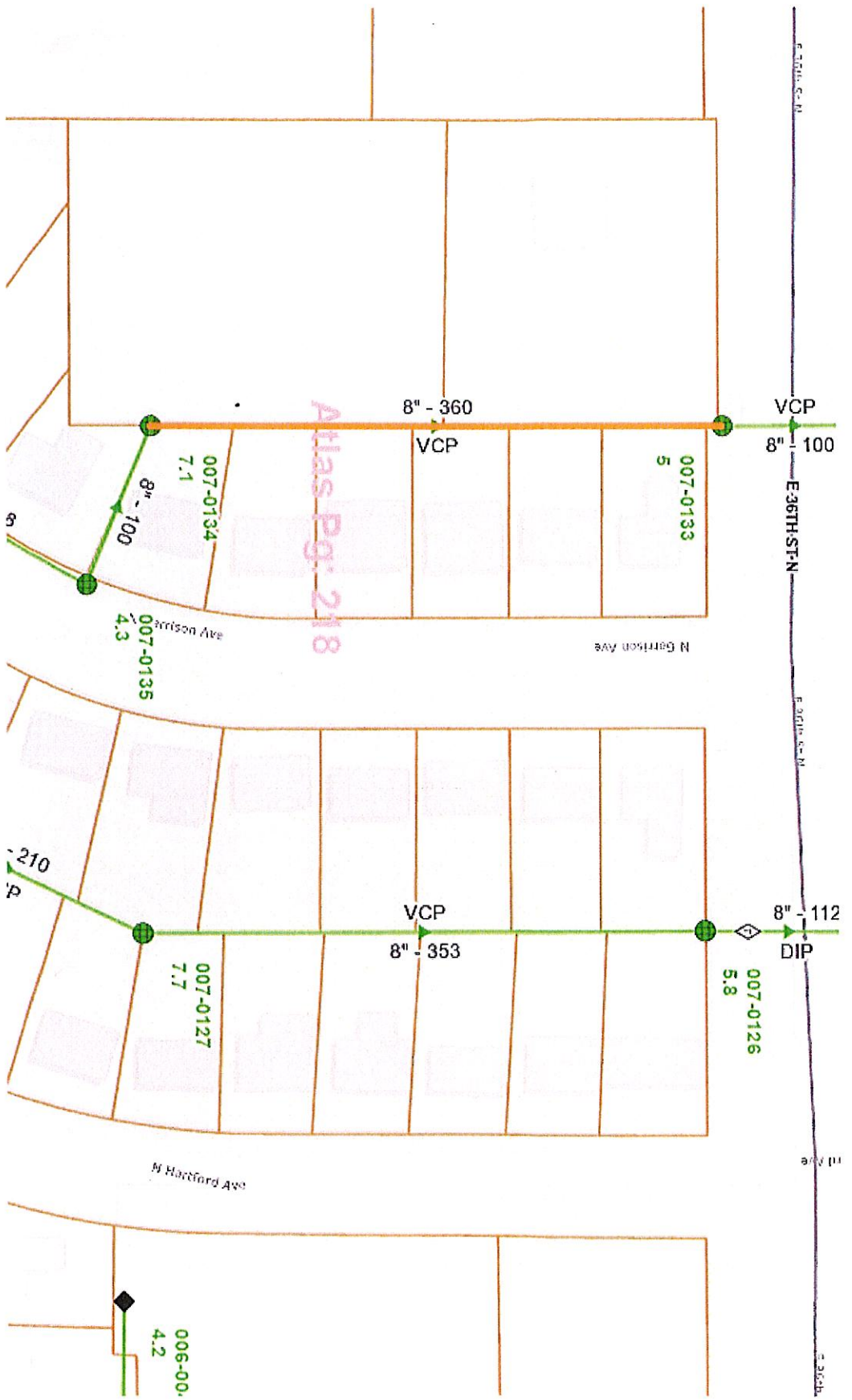



Atlas Pg: 432

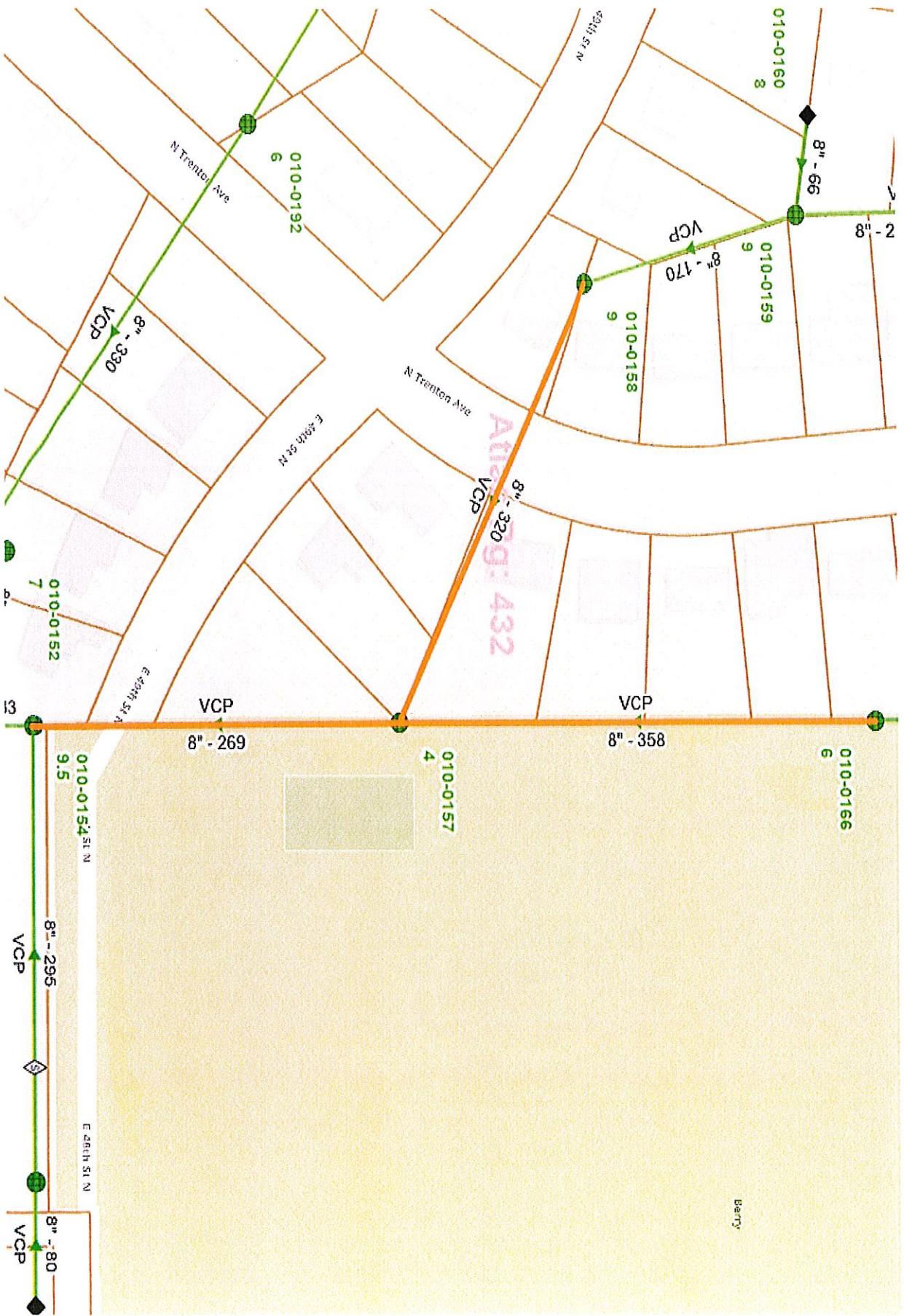

Attachment: 432

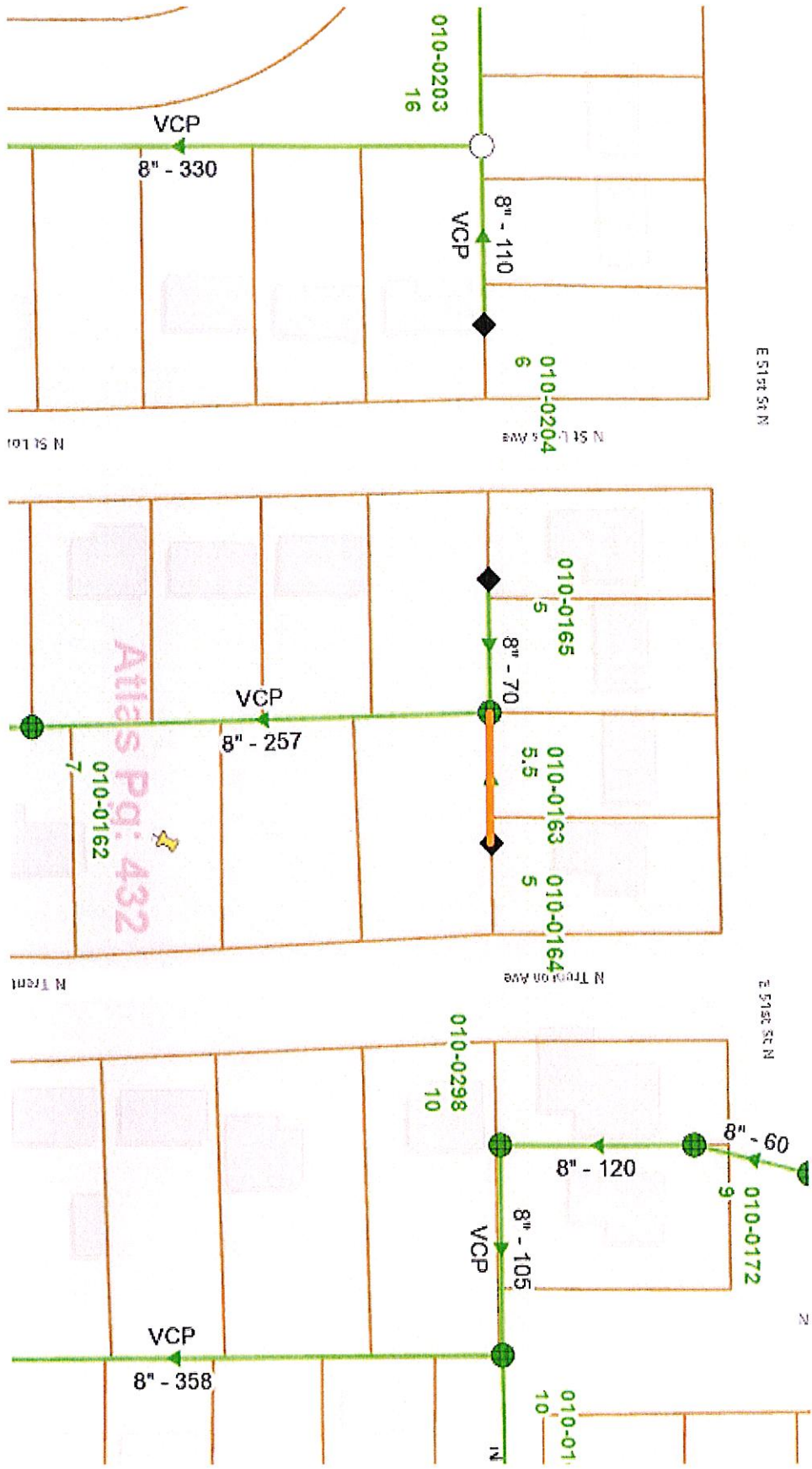



Atlas
432



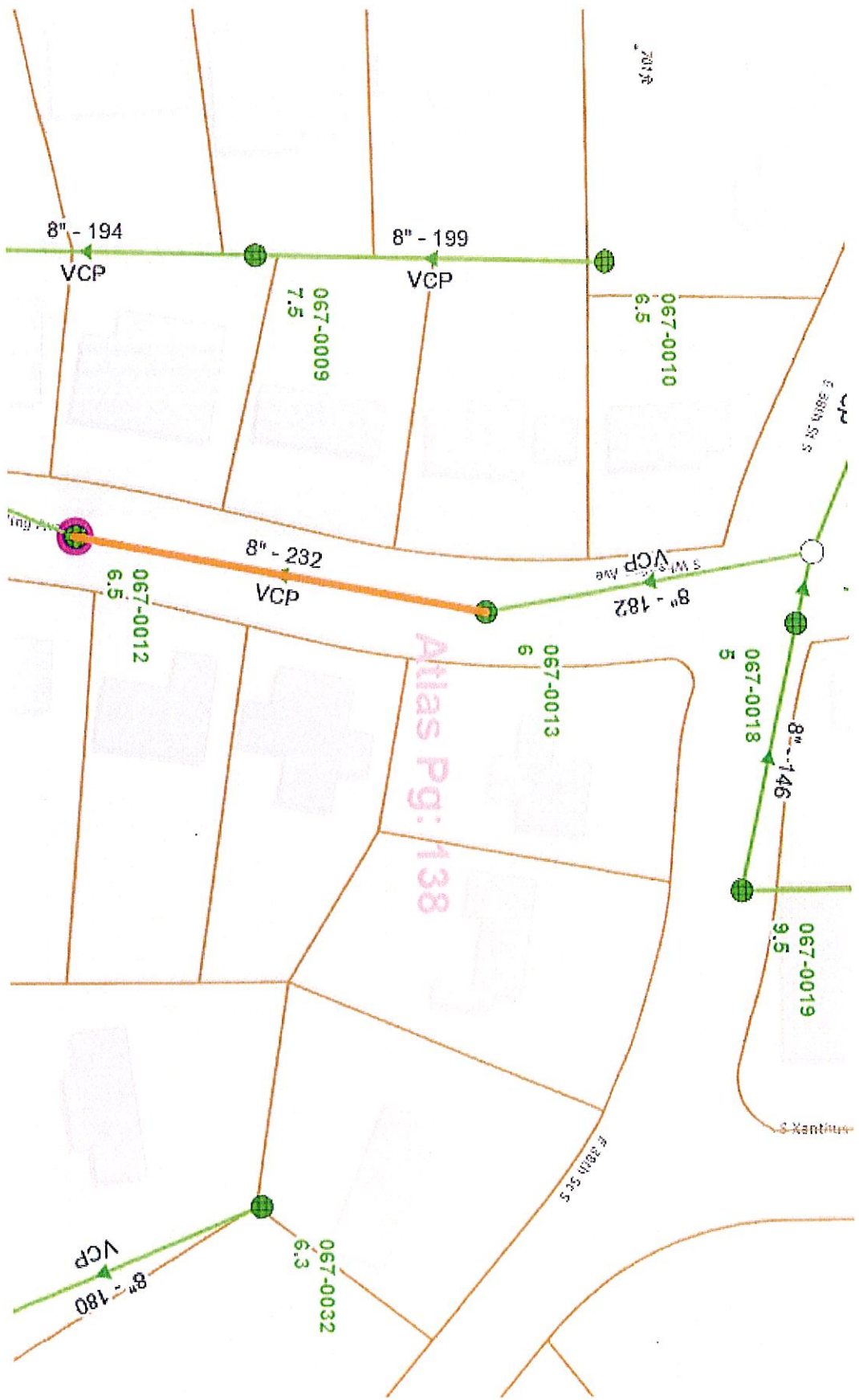

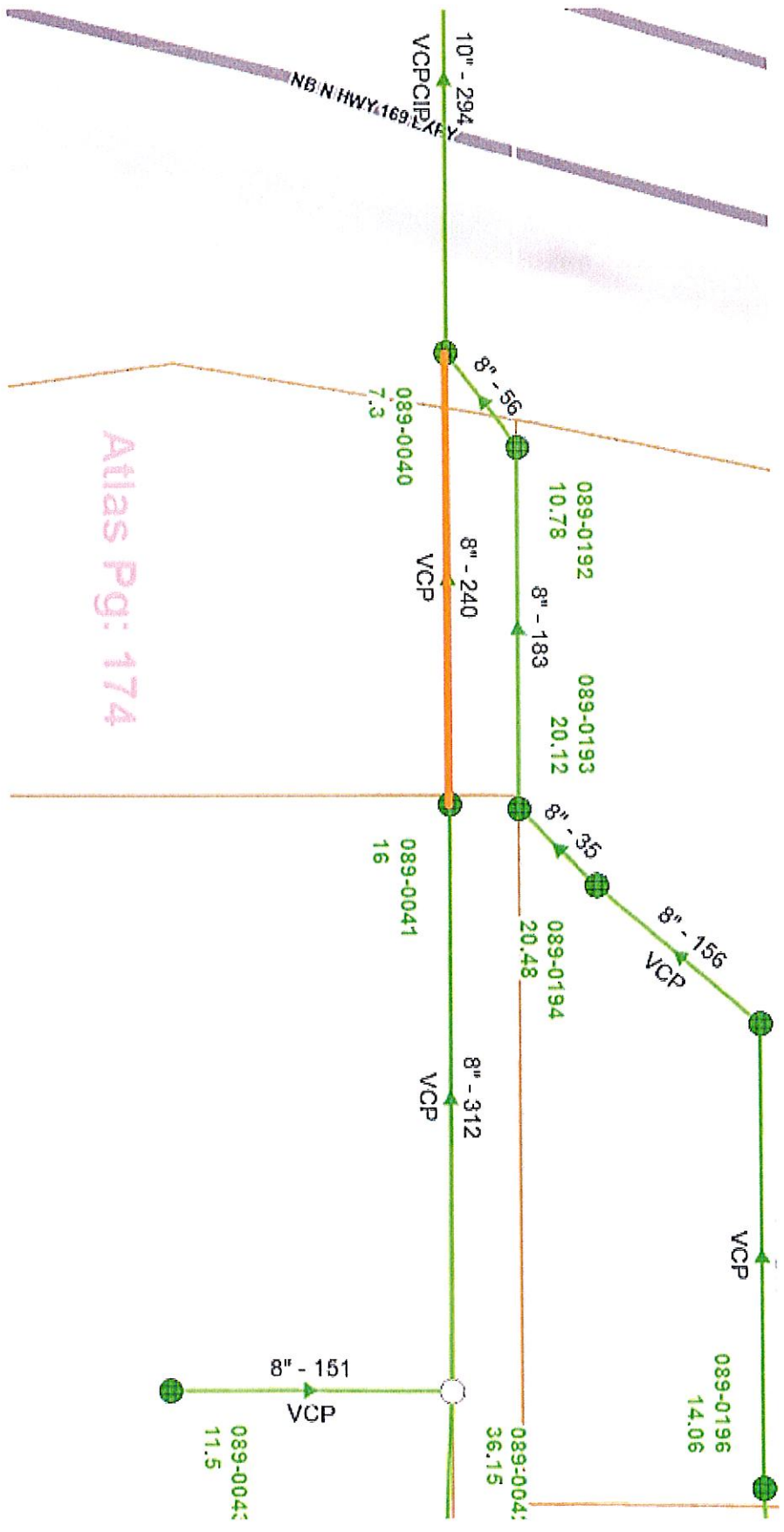

Atlas Pg: 174

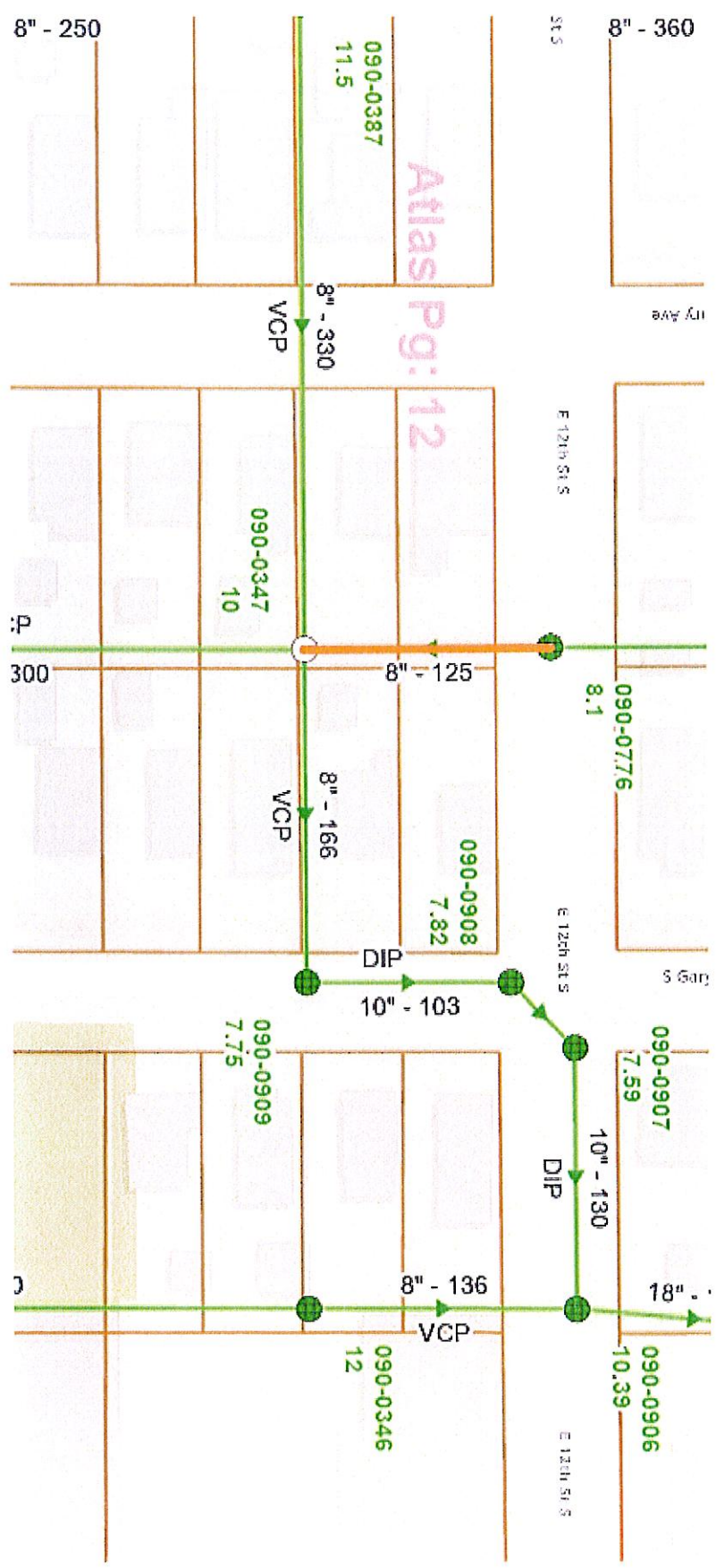



: 28

At

3200 Series Composite Utility Access Cover with Quarter Turn Paddle Locks



COMPOSITES INC.

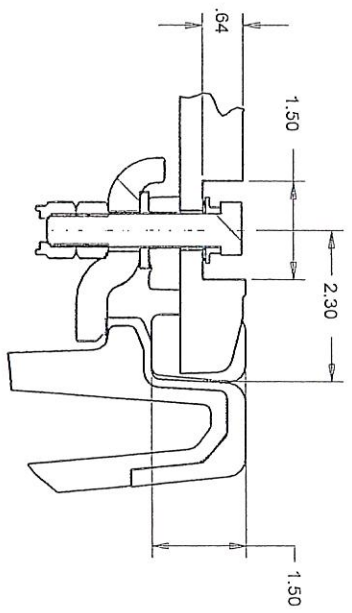
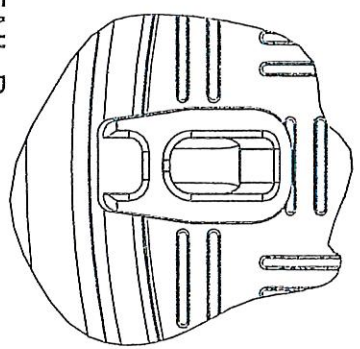
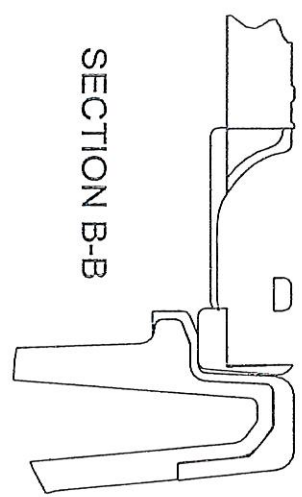
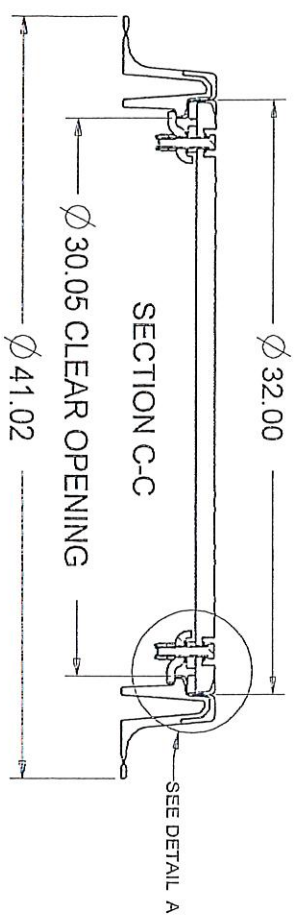
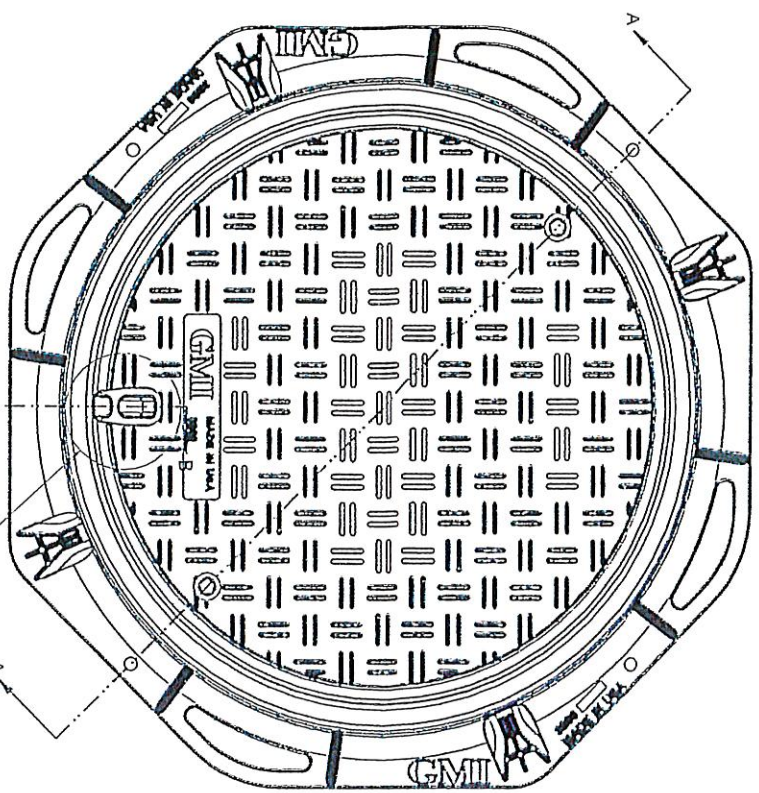

Product/ Drawing Number

3200AAE100

Product Attributes

Materials:

Fiber Reinforced Polymer

Load Rating:

AASHTO M306-05
H-20 & H25
EN/24 D400

Weight

Cover = 50lbs
Frame = 42lbs

Lock Option:

2 Quarter Turn Paddle Locks

MADE IN USA

This drawing is the property of GMI Composites, INC. and includes confidential information, trade secret information, and/or know how that is the property of GMI Composites, INC. Copyright 2010 GMI Composites, INC.

PATH: /e1/parts/sd/DGN_std/359-Flood Plain and Cover Detail.dgn DRB 9/19/2023

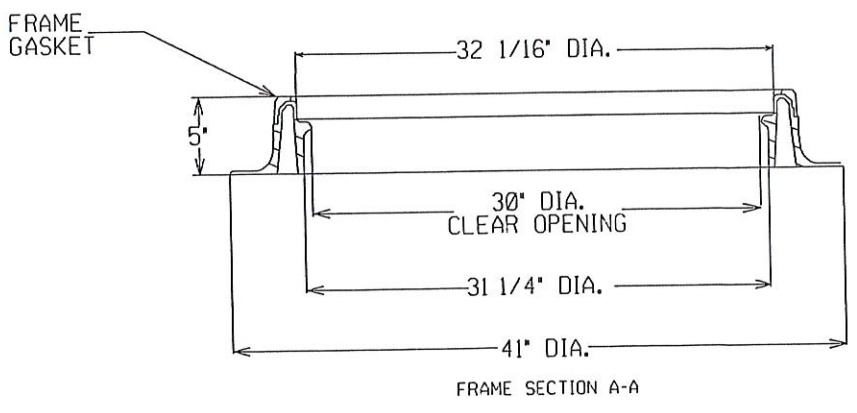
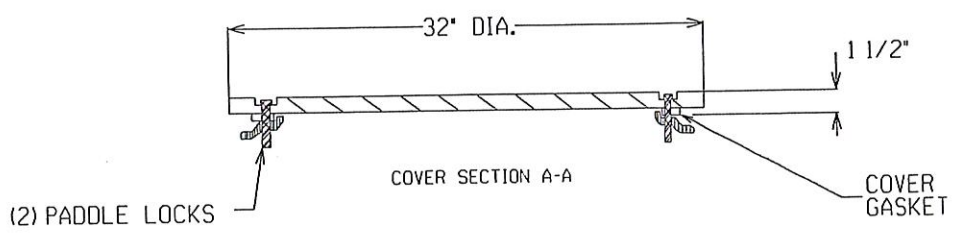
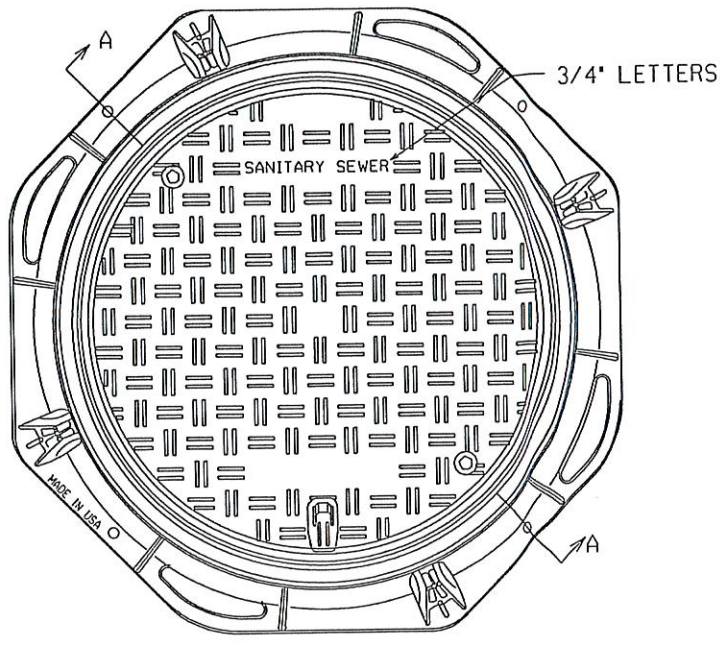

NOTE:

1. FRAME AND COVER TO BE 3200 SERIES COMPOSITE UTILITY ACCESS COVER WITH QUARTER TURN PADDLE LOCKS MANUFACTURED BY EJ GROUP, INC. OR ENGINEER APPROVED EQUAL.
2. FRAME AND COVER TO MEET AASHTO M306 AND BE MANUFACTURED IN THE USA.

FRAME AND COVER FOR FLOOD PLAIN APPLICATION	
CITY OF TULSA, OKLAHOMA PUBLIC WORKS DEPARTMENT	
DRAWN BY: D.R.B. CHECKED BY: DATE: SEPT. 2023	APPROVED 
NOT TO SCALE	STANDARD NO. 359

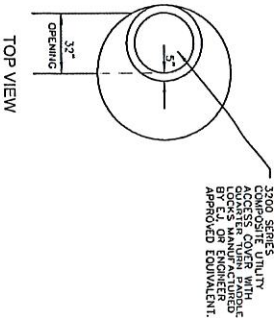
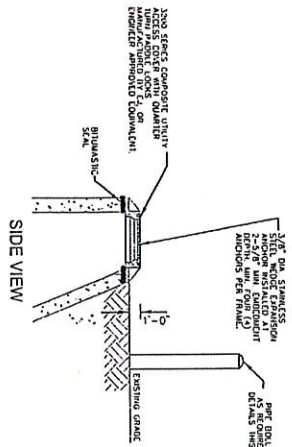

ELEVATED DETAIL FOR ECCENTRIC MANHOLES

- NOTES:
1. ALL MANHOLE COVERS SHOWN ON THIS SHEET SHALL BE FURNISHED WITH WATER RESISTANT CASKETS.
 2. ALL OTHER COMPONENTS OF PRECAST CONCRETE MANHOLES SHALL BE PER CITY OF TULSA STANDARD DETAIL NO. 331, 336, 337, AND 338 AS APPLICABLE.

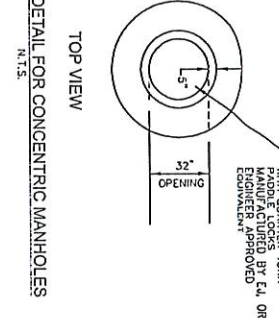
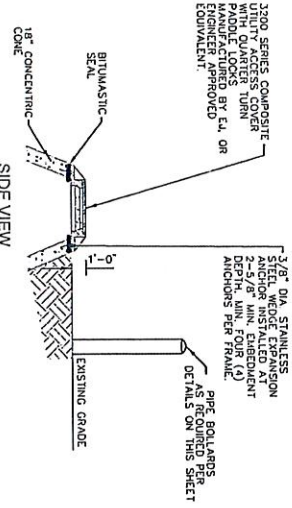

ELEVATED DETAIL FOR CONCENTRIC MANHOLES

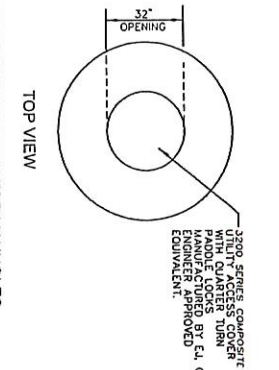
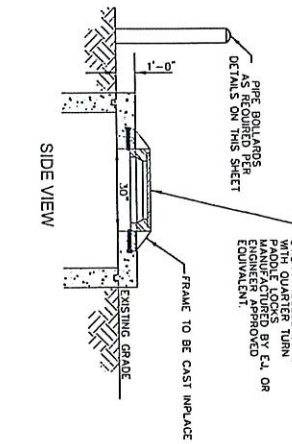
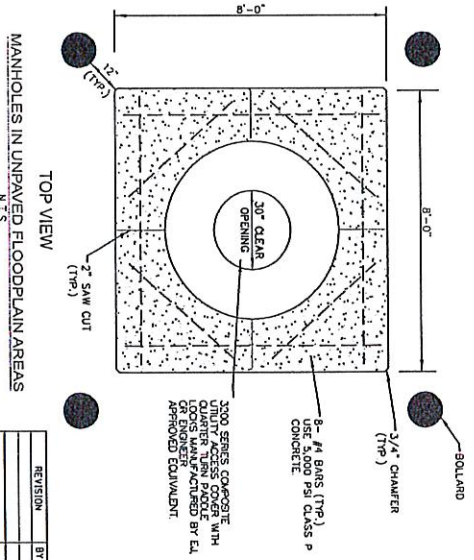
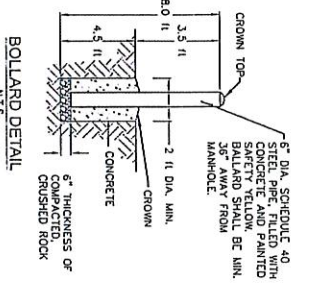

ELEVATED DETAIL FOR FLAT TOP MANHOLES

REVISION	BY	DATE

JASON W. JOHNSON
 PROFESSIONAL ENGINEER
 NO. 10000
 STATE OF OKLAHOMA

CITY OF TULSA, OKLAHOMA
 PUBLIC WORKS DEPARTMENT
 STANDARD ELEVATED MANHOLE
 DETAILS FOR FLOODPLAIN
 CONSTRUCTION
 510.366

DATE: MARCH 2023

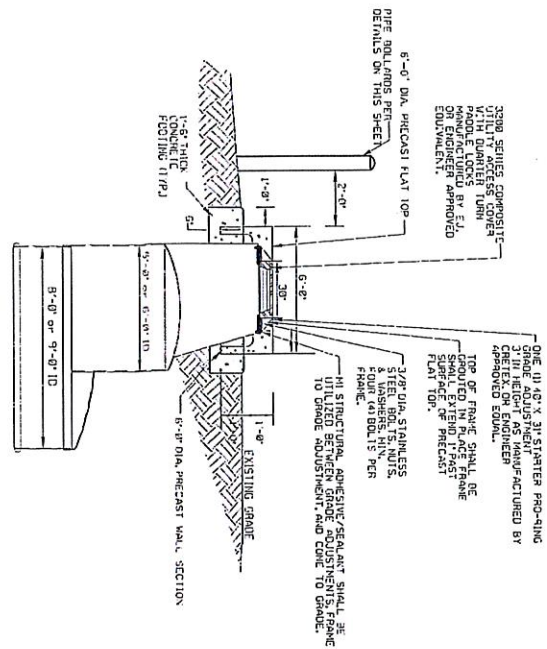

8' or 9'-ID FRP MANHOLE WITH 6'-ID PRECAST WALL SECTION AND FLAT TOP
N.T.S.

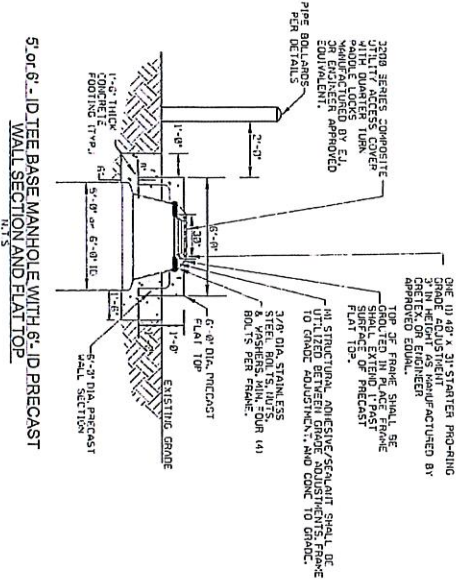

5' or 6'-ID TEE BASE MANHOLE WITH 6'-ID PRECAST WALL SECTION AND FLAT TOP
N.T.S.

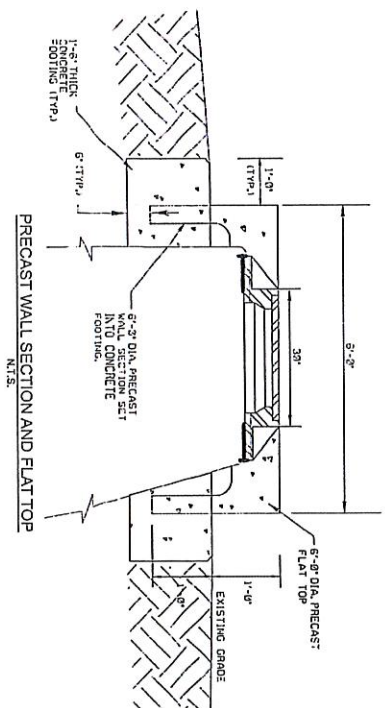

PRECAST WALL SECTION AND FLAT TOP
N.T.S.

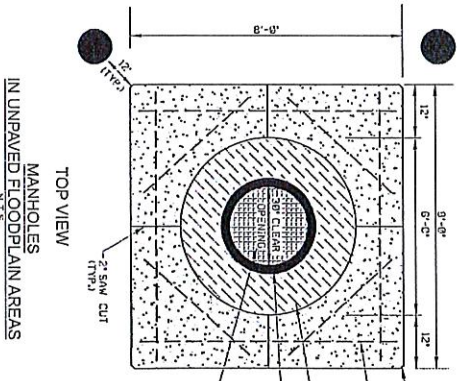

TOP VIEW
MANHOLES
IN UNPAVED FLOODPLAIN AREAS
N.T.S.

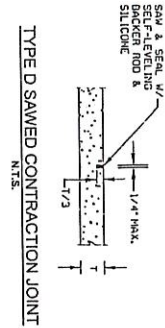

TYPE D SAWED CONTRACTION JOINT
N.T.S.

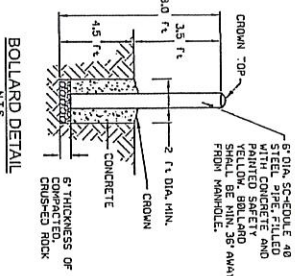

BOLLARD DETAIL
N.T.S.

NOTE:
1. PIPE BOLLARDS SHALL BE POLYMER CASTED SAFETY YELLOW.

REVISION	BY	DATE

CITY OF TULSA, OKLAHOMA PUBLIC WORKS DEPARTMENT STANDARD ELEVATED FRP MANHOLE DETAILS	DATE: AUGUST 2023 STD. 248
--	-------------------------------

PATH NAME: /E1/PARTS/STD/DGN/STD/370-HYDRAULIC SLIDE MANHOLE DETAIL.DGN DJN 09/19/2023

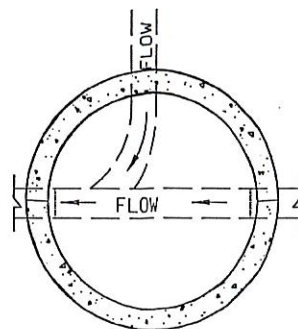
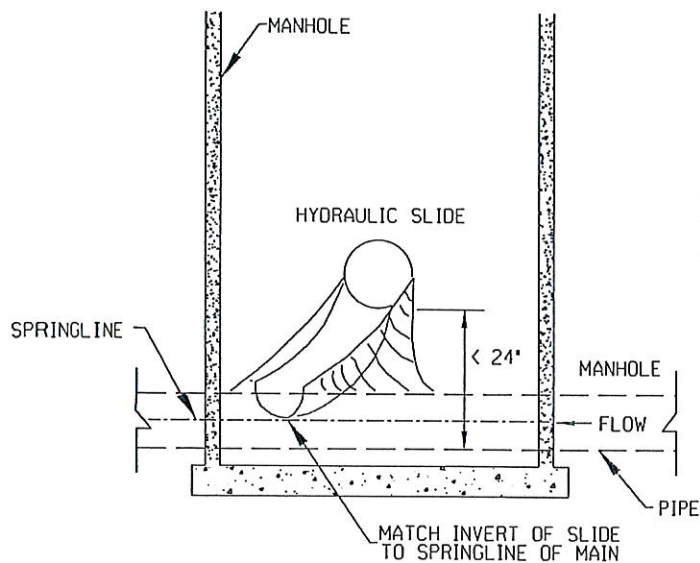

WHEN INSTALLING HYDRAULIC SLIDE THAT INTERCEPTS AN EXISTING SEWER AT A RIGHT ANGLE, THE CONNECTING INVERT OF THE HYDRAULIC SLIDE IS TO INTERCEPT THE EXISTING SEWER SLIGHTLY ABOVE THE SPRINGLINE AS SHOWN. DISTANCE MEASURED FROM INVERT TO INVERT.

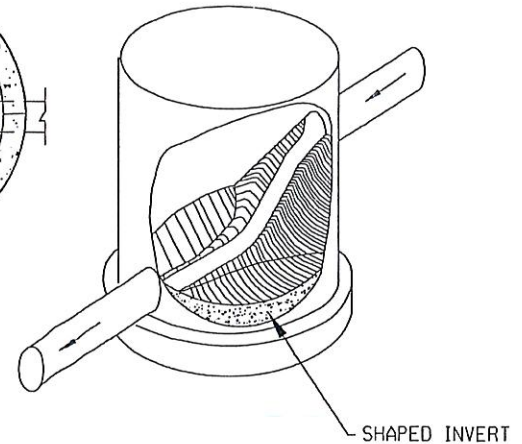
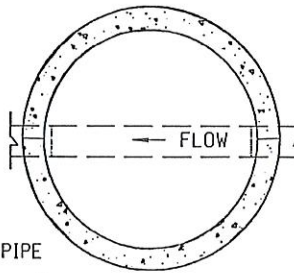
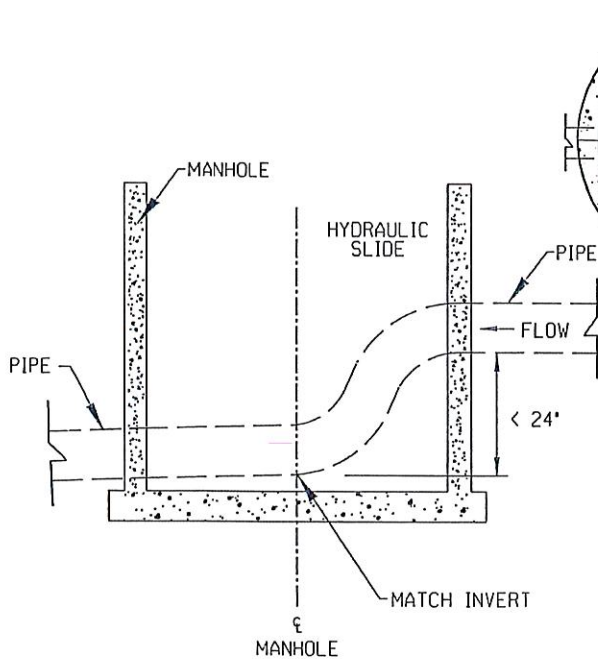

WHEN INSTALLING HYDRAULIC SLIDE WHERE THE FLOW IS STRAIGHT THROUGH THE MANHOLE, THE HYDRAULIC SLIDE IS TO MATCH THE INVERT OF EXISTING LINE AND NOT EXTEND MORE THAN HALF-WAY THROUGH THE MANHOLE. DISTANCE MEASURED FROM INVERT TO INVERT.

NOTE:

1. MATERIAL USED TO COMPLETE HYDRAULIC SLIDE SHALL CONFORM TO SECTION 421.2 OF THE CITY OF TULSA CONSTRUCTION SPECIFICATIONS
2. HYDRAULIC SLIDES ARE NOT A SEPARATE PAY ITEM.

HYDRAULIC SLIDE MANHOLE DETAIL	
CITY OF TULSA, OKLAHOMA PUBLIC WORKS DEPARTMENT	
DRAWN BY: D.J.N	APPROVED
CHECKED BY:	
DATE: AUGUST 2023	
NOT TO SCALE	STANDARD NO. 370

PATH NAME: /E1/PARTS/STD/DGN/STDS/416-PIPE-BURST-OROP.DGN DJN 10/18/2023

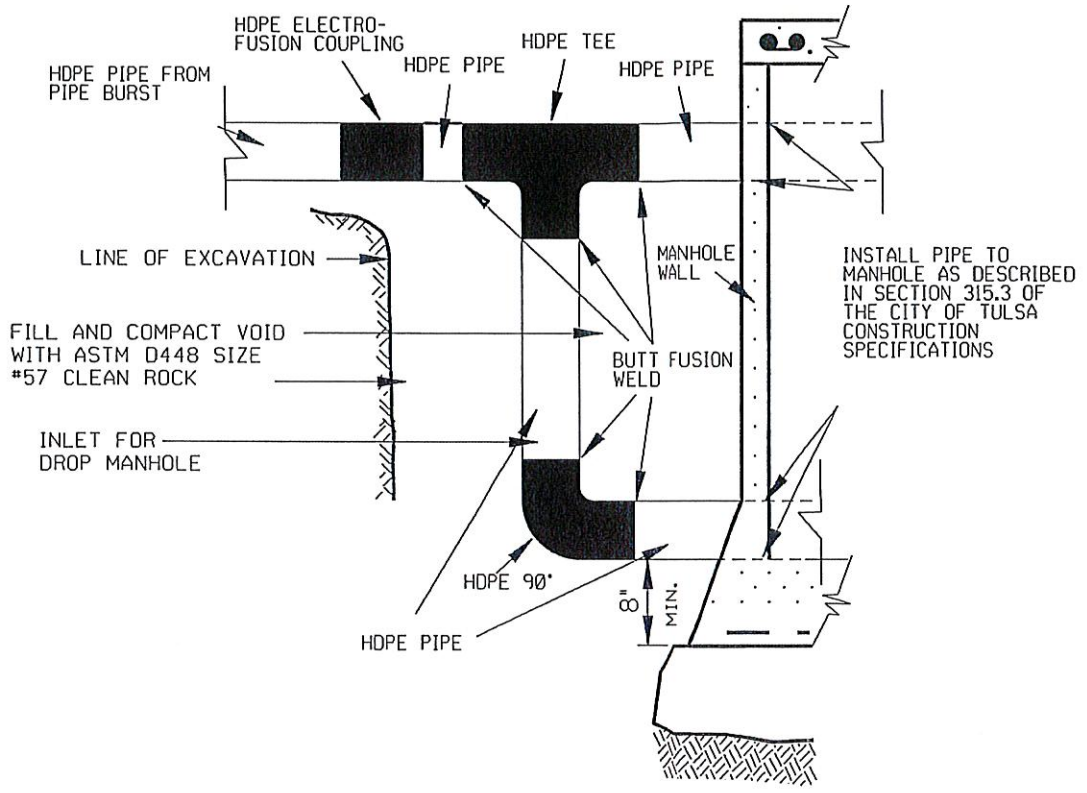

INSTALL PIPE TO MANHOLE AS DESCRIBED IN SECTION 315.3 OF THE CITY OF TULSA CONSTRUCTION SPECIFICATIONS

NOTE:

1. HDPE 90 TO BE MANUFACTURED BY GEORGE FISCHER CENTRAL PLASTICS SHAWNEE, OK WITH DR 11PE4710 HDPE PIPE MEETING ASTM F714/D3035 AWWA C901/C906
2. HDPE TEE TO BE MANUFACTURED BY GEORGE FISCHER CENTRAL PLASTICS SHAWNEE, OK WITH DR11 PE4710 HDPE PIPE MEETING ASTM D2513/D3261, AWWA C906.
3. HDPE ELECTRO-FUSION COUPLING TO BE MANUFACTURED BY GEORGE FISCHER CENTRAL PLASTICS BASED OUT OF SHAWNEE, OK
4. HDPE PIPE SHALL MEET SECTION 408 OF CITY STANDARD SPECIFICATIONS.

STANDARD DETAIL DROP DETAIL FOR PIPE BURST LINE	
CITY OF TULSA, OKLAHOMA PUBLIC WORKS DEPARTMENT	
DRAWN BY: D.J.N. CHECKED BY: DATE: OCT.18 2023	APPROVED 
NOT TO SCALE	STANDARD NO. 416

PATH NAME: /E1/PARTS/STD/DCN.STDS/417-SLIPLINE-PIPE-DROP.DGN DJN 10/18/2023

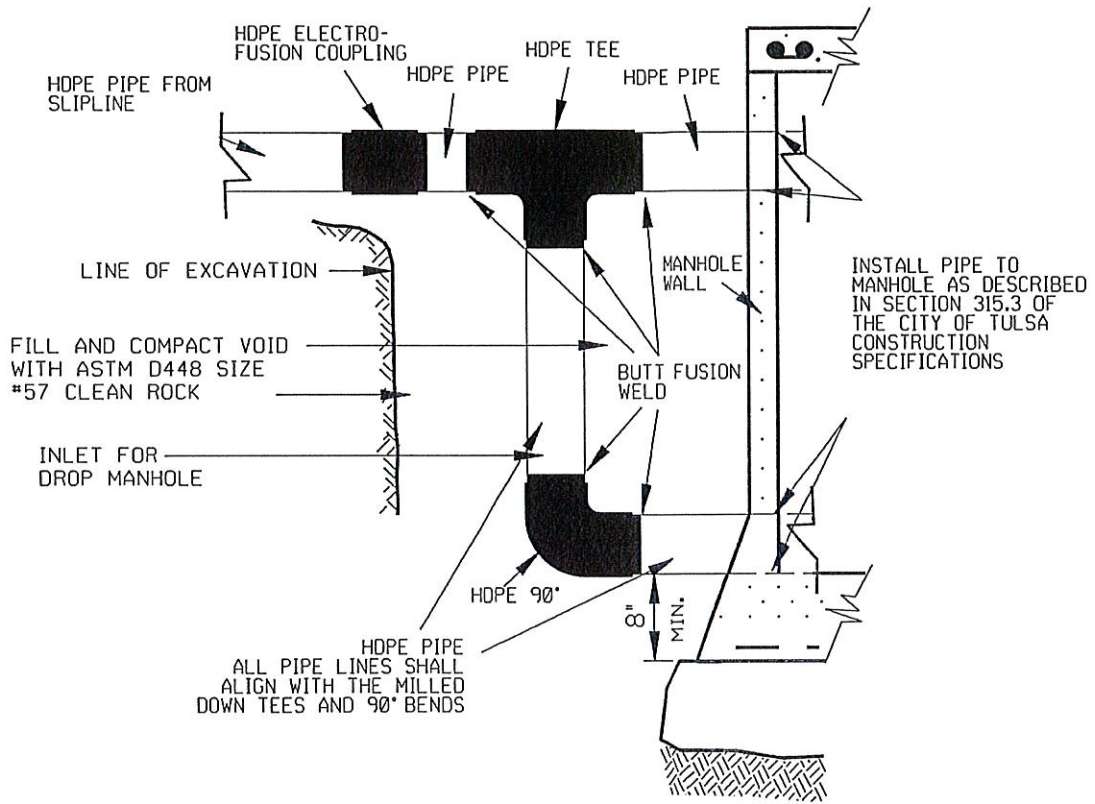

NOTE:

1. HDPE TEE AND HDPE 90 FEEDSTOCK TO BE SDR7 PE4710 HDPE PIPE MEETING ASTM F714/D3035, AWWA C901/C906 WITH THE FIRST 3' OF THE OUTSIDE DIAMETER OF THE CONNECTING ENDS REDUCED TO MATCH THE OUTSIDE DIAMETER OF THE SLIPLINE PIPE, SO THAT THEY CAN BE PROPERLY FUSED.
2. HDPE ELECTRO-FUSION COUPLING TO BE MANUFACTURED BY GEORGE FISCHER CENTRAL PLASTICS BASED OUT OF SHAWNEE, OK
3. HDPE PIPE SHALL MEET SECTION 409 OF CITY STANDARD SPECIFICATIONS.

DROP DETAIL 8" HOST PIPE WITH 7.125' SLIPLINE PIPE	
CITY OF TULSA, OKLAHOMA PUBLIC WORKS DEPARTMENT	
DRAWN BY: D.J.N. CHECKED BY: DATE: OCT. 18 2023	APPROVED
NOT TO SCALE	STANDARD NO. 417

PATH NAME: \\EL\PARTS\STD\DCN\STDS\418-SLIPLINE-PIPE-DROP-10-OR-CREATER.DGN DJN 10/18/2023

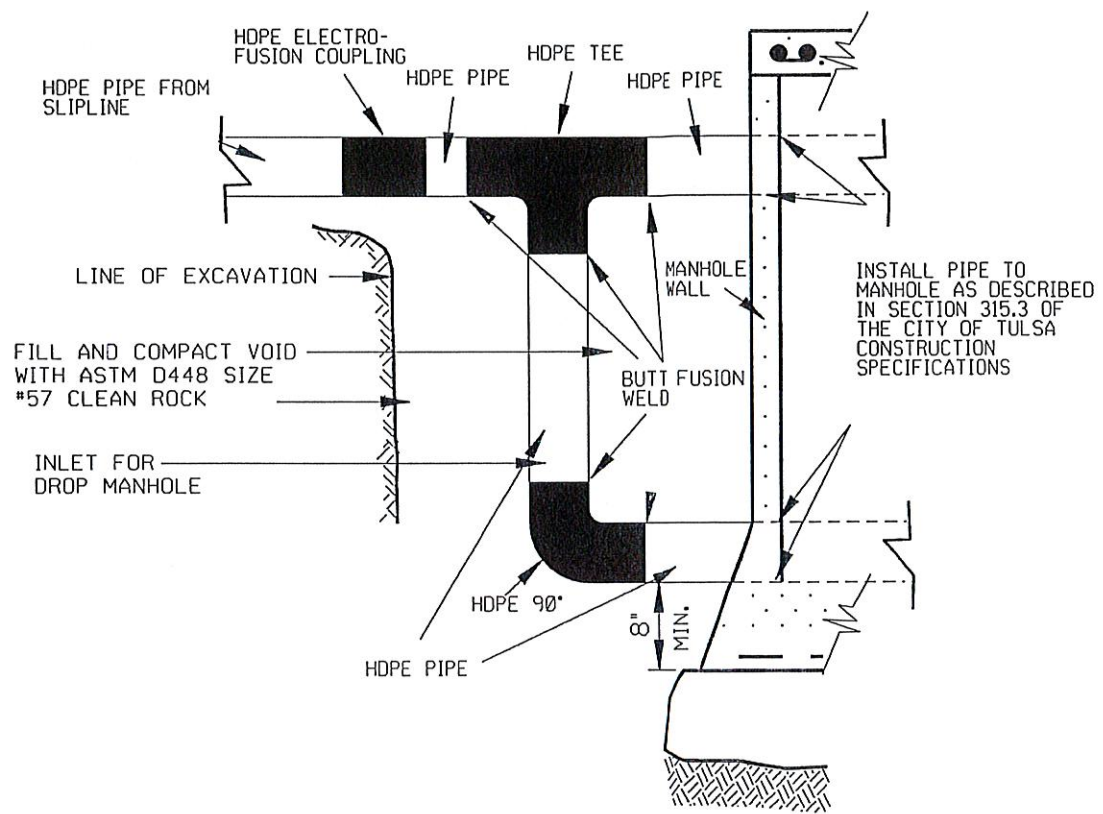

INSTALL PIPE TO MANHOLE AS DESCRIBED IN SECTION 315.3 OF THE CITY OF TULSA CONSTRUCTION SPECIFICATIONS

NOTE:

1. HDPE 90 TO BE MANUFACTURED BY GEORGE FISCHER CENTRAL PLASTICS SHAWNEE, OK WITH DR 11 PE4710 HDPE PIPE MEETING ASTM F714/D3035 AWWA C901/C906
2. HDPE TEE TO BE MANUFACTURED BY GEORGE FISCHER CENTRAL PLASTICS SHAWNEE, OK WITH DR11 PE4710 HDPE PIPE MEETING ASTM D2513/D3261, AWWA C906.
3. HDPE ELECTRO-FUSION COUPLING TO BE MANUFACTURED BY GEORGE FISCHER CENTRAL PLASTICS BASED OUT OF SHAWNEE, OK
4. HDPE PIPE SHALL MEET SECTION 409 OF CITY STANDARD SPECIFICATIONS.

DROP DETAIL FOR A SLIPLINE WITH A HOST PIPE DIAMETER OF 10' OR GREATER	
CITY OF TULSA, OKLAHOMA PUBLIC WORKS DEPARTMENT	
DRAWN BY: D.J.N. CHECKED BY: DATE: OCT. 18 2023	APPROVED
NOT TO SCALE	STANDARD NO. 418

PATH NAME: /E1/PARTS/STD/DGNL/STD/419-MANHOLE OUTSIDE DROP CONNECTIONS.DGN D.J.N 09/16/2024

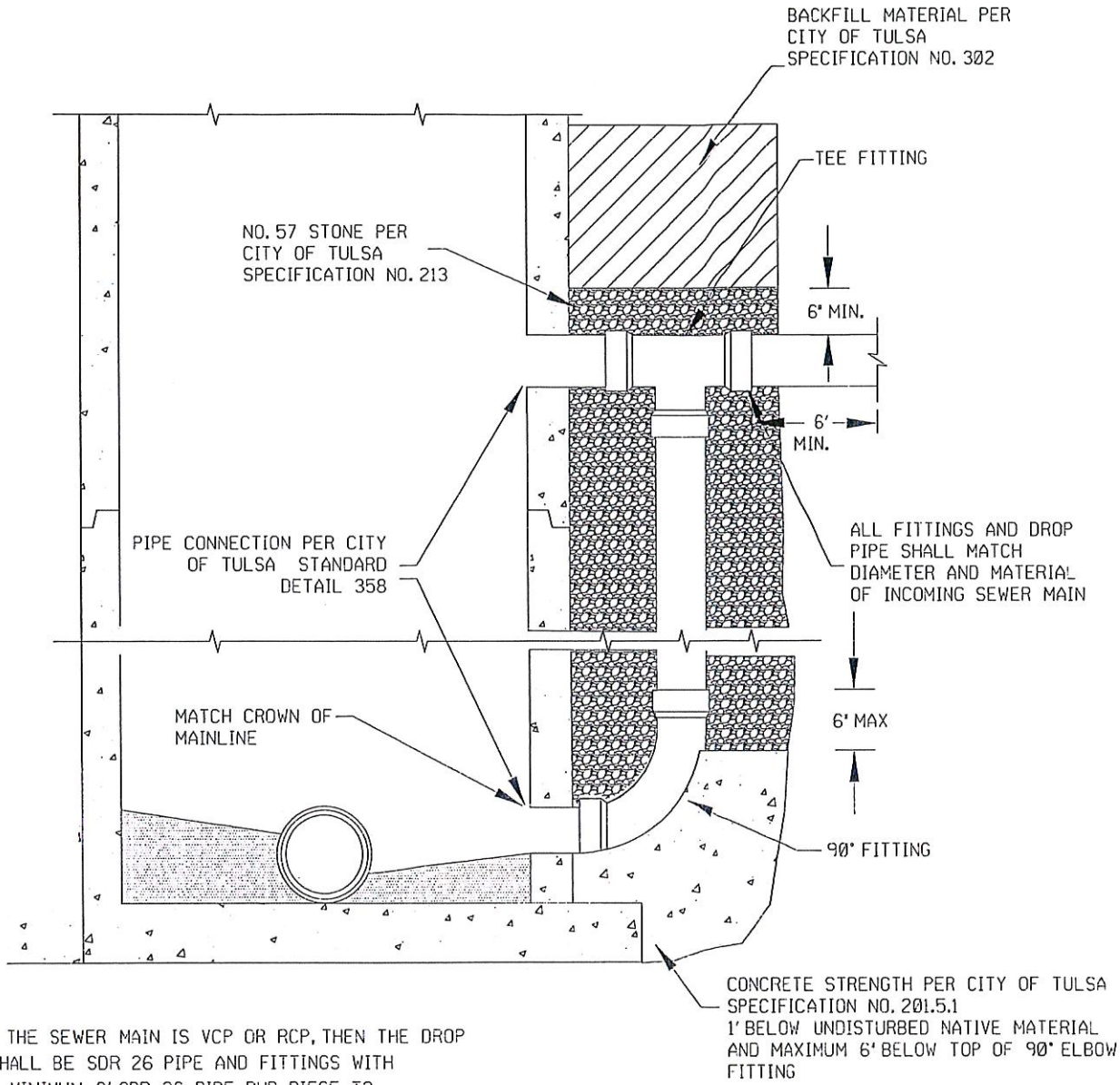

NOTE: IF THE SEWER MAIN IS VCP OR RCP, THEN THE DROP SHALL BE SDR 26 PIPE AND FITTINGS WITH A MINIMUM 6' SDR 26 PIPE PUP PIECE TO THE VCP/RCP TRANSITION COUPLING

STANDARD DETAIL MANHOLE OUTSIDE DROP CONNECTIONS	
CITY OF TULSA, OKLAHOMA WATER & SEWER DEPARTMENT	
DRAWN BY: D.J.N.	APPROVED
CHECKED BY:	
DATE: SEPI. 2024	
NOT TO SCALE	STANDARD NO. 419

Contractor Name	Work Order #	Atlas Page	UP Area	UP MH	UP MH Depth	DN Area	DN MH	DN MH Depth	Pipe Length		
Circle Construction Type:		Pipeburst	Slipline	CIPP	Point Repair	Open Cut	Pipe Size:	Pipe Type:			
Point Repair Only						Total Pipe Replaced		Date Completed			
Pipe Replaced @:		Ft to	Ft From	MH							
Service Address	Fig. From DS or US MH	Clock position from DS or US MH	Type service connect at main	Fig. Service pipe installed by Crew	Size of service pipe	Type of service pipe	Type of coupling	Size and material existing service pipe	Depth of connect to existing service pipe	Depth to top of pipe	Date connected
UPSTREAM MANHOLE REHAB (Circle all that apply)											
Type of Rehab:	Complete Replacement	Type A	Type B	Type C	Type D	Type F	Type Gg	Type Gh	Type Gk		
Type Go	Type Gp	Type Gr	Type Gs	Type Ft	Type Fc	Type Fw	Type Fi				
DOWNSTREAM MANHOLE REHAB (Circle all that apply)											
Type of Rehab:	Complete Replacement	Type A	Type B	Type C	Type D	Type F	Type Gg	Type Gh	Type Gk		
Type Go	Type Gp	Type Gr	Type Gs	Type Ft	Type Fc	Type Fw	Type Fi				

Contractor Foreman: _____

Sign & Date

Inspector: _____

Sign & Date

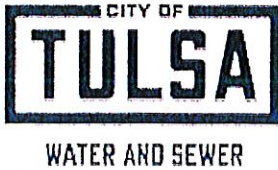

Sewer Operations and Maintenance
WATER AND SEWER DEPARTMENT
Sanitary Sewer By-Pass Pumping Notification

Contractor: _____ Project: _____

Inspector: _____ Inspector Phone: _____

City Engineer _____ City Eng Phone: _____

By-Pass Pumping Start Date _____ Expected End Date: _____

Address: _____

Pump will be installed in manhole #: _____ Pump will discharge to manhole #: _____

Plan for pump operation to prevent sewage overflows:

How will pump be monitored after hours to ensure no pumping disruption?

[Empty rectangular box for plan details]

After-hour contact information for Contractor:

Primary

Name: _____ Number(s): _____

Secondary

Name: _____ Number(s): _____

- 1. Form should be emailed to the Sewer Operations personnel at SOMDispatch@cityoftulsa.org, 1-week prior to by-pass pumping event.
2. Attach to this notification any approved by-pass pumping submittals.
3. If advanced notice cannot be given, form should be emailed immediately after beginning by-pass pumping and Emergency Sewer Response at 918-586-6999 should be contacted.

In the event of sewage overflow or any other emergency while by-pass pumping, call Emergency Sewer Response at 918-586-6999 for 24-Hour Service.

CITY OF
TULSA