



PUBLIC WORKS
Engineering

DATE: October 08, 2024

TO: PAUL ZACHARY P.E.,
PUBLIC WORKS DEPUTY
DIRECTOR

FROM: H. SOMDECERFF,
PUBLIC WORKS DESIGN
MANAGER

Standards and Specifications for Sanitary Sewer Long Service.

The Specification Review Committee recommends and asks the Public Works Deputy Director to approve the following:

1. Approve Detail No. 313A - Standard Valve Box.

Please call me at (918) 596-7355 If you have any questions.

Thank you,

APPROVED:

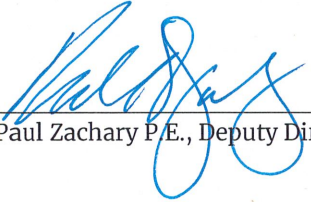

Paul Zachary P.E., Deputy Director

10.11.24

Date

Cc: Engineering Services Department Specification Review Committee

1898 * 1898

TUL * USA

PATH NAME: /E1/PARTS/STD/DGN_STDS/313A-VALVEBOX.DGN DJN 10/10/2024

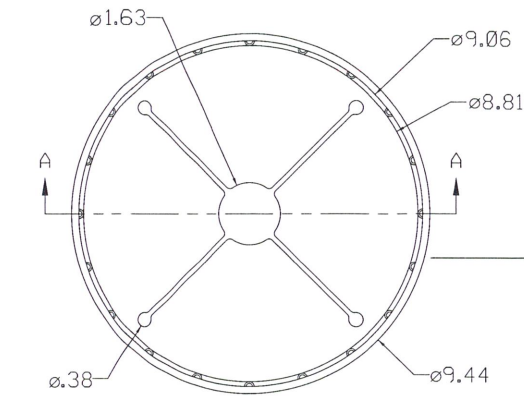

VB STABILIZER 5 1/4 PLASTIC
VALVE BOX BOTTOM 101/106
BELL

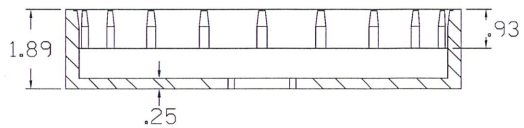
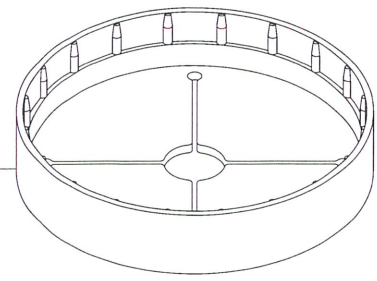

SECTION A-A

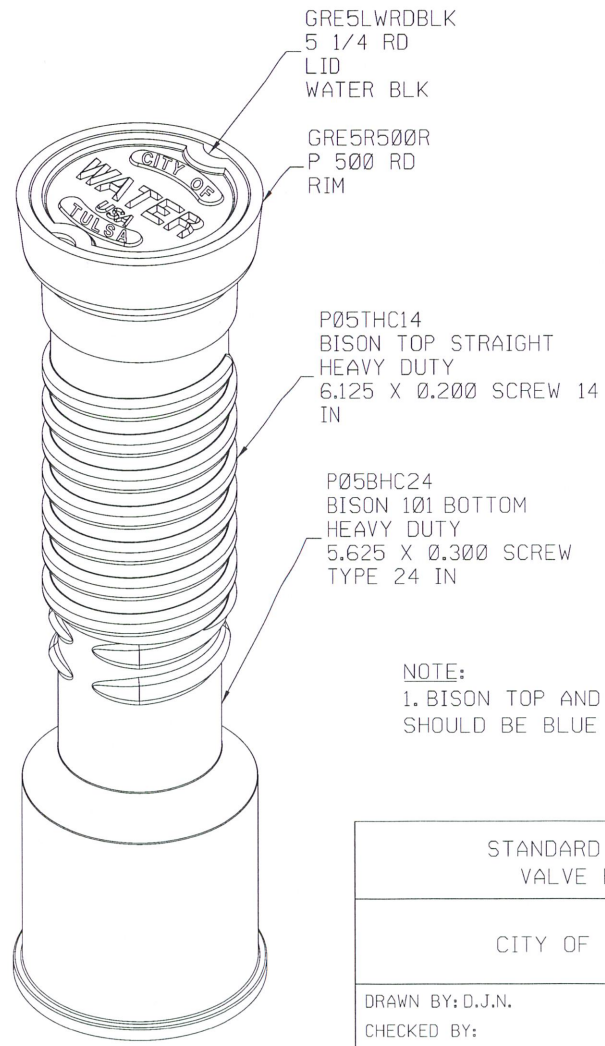
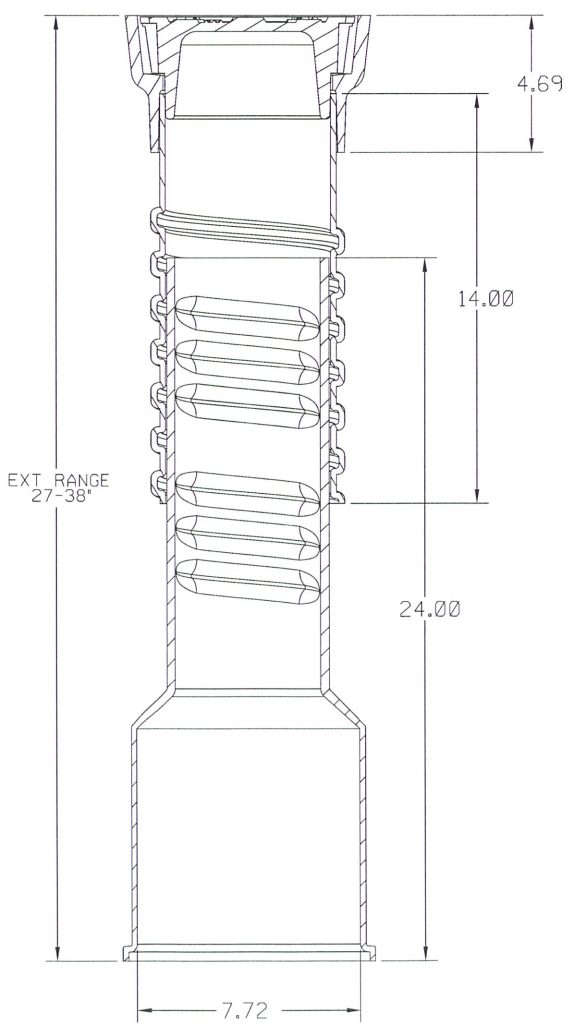

NOTE:
1. BISON TOP AND BOTTOM
SHOULD BE BLUE IN COLOR

STANDARD DETAIL VALVE BOX	
CITY OF TULSA	
DRAWN BY: D.J.N. CHECKED BY: DATE: OCT. 2024	APPROVED
NOT TO SCALE	STANDARD NO. 313A