

9/4/2024

INVITATION FOR BID TAC 1299

Addendum #3

Please note the following changes which have been made for clarification to this Invitation for Sealed Bid. **This addendum must be listed as Addendum #3 on the ACKNOWLEDGMENT OF RECEIPT OF ADDENDA/AMENDMENTS FORM** of the bid package as verification that you have received and are aware of the information contained herein.

QUESTIONS/CLARIFICATION/CHANGES:

CHANGES:

Was:

Item	Description	Est Annual QTY	Unit Cost	Extended Cost	Manufacturer & Part Number
1.	Darco H2S LP	70,000 LBS.	\$	\$	
2.	Labor: Complete Service to Remove / Replace, Inspect, Clean, and Dispose of Old Carbon Per Scope of Service and Specifications Locations as specified in Specifications.			\$ _____/HR	
3.	Labor: Complete Service to Remove / Replace, Inspect, Clean, and Dispose of Old Carbon Per Scope of Service and Specifications Additional potential locations as requested by the City.			\$ _____/HR	
TOTAL EXTENDED COST NOT TO EXCEED: (All costs must be included or Your Bid will be disqualified)			\$	_____	

Changed to:

Item	Description	Est Annual QTY	Unit Cost	Extended Cost	Manufacturer & Part Number
1.	Darco H2S LP	70,000 LBS.	\$	\$	
2.	Labor: Complete Service to Remove / Replace, Inspect, Clean, and Dispose of Old Carbon Per Scope of Service and Specifications Locations as specified in Specifications.			\$ _____/HR	
3.	Labor: Complete Service to Remove / Replace, Inspect, Clean, and Dispose of Old Carbon Per Scope of Service and Specifications Additional potential locations as requested by the City.			\$ _____/HR	

QUESTIONS:

- Can you please share the cubic feet requirements for each one of the tanks that need to be serviced?
[Spunky Creek is 85 CUFT, Lower Bird Creek is 340 CUFT and 460 CUFT, Cherry Creek, Sheridan LS is 45 CUFT, and Haikey Creek is 160 CUFT.](#)
- Zane mentioned the landfill information that he was going to relay to you for spent activated carbon disposal. He also mentioned that the water plant already has the approval to dump to the specific landfills.
[American Environmental Landfill Inc. 212 N 177th W Ave Sand Springs, OK., 74063, phone 918-245-7786. This is who we currently use for our needs, but the company that gets the contract would need to get their own permit to dump there.](#)

DRAWINGS HAVE BEEN INCLUDED AT THE END OF THIS DOCUMENT – Pages 26-36

8/15/2024

INVITATION FOR BID TAC 1299

Addendum #2

Please note the following changes which have been made for clarification to this Invitation for Sealed Bid. **This addendum must be listed as Addendum #2 on the ACKNOWLEDGMENT OF RECEIPT OF ADDENDA/AMENDMENTS FORM** of the bid package as verification that you have received and are aware of the information contained herein.

QUESTIONS/CLARIFICATION/CHANGES:

CHANGES:

Was:

Pricing:

Item	Description	Est Annual QTY	Unit Cost	Extended Cost	Manufacturer & Part Number
1.	Darco H2S LP	70,000 LBS.	\$	\$	
2.	Labor: Complete Service to Remove / Replace, Inspect, Clean, and Dispose of Old Carbon Per Scope of Service and Specifications	7 Vessels	\$	\$	
TOTAL EXTENDED COST NOT TO EXCEED: (All costs must be included or Your Bid will be disqualified)			\$ _____		

Changed to:

Pricing:

Item	Description	Est Annual QTY	Unit Cost	Extended Cost	Manufacturer & Part Number
1.	Darco H2S LP	70,000 LBS.	\$	\$	
2.	Labor: Complete Service to Remove / Replace, Inspect, Clean, and Dispose of Old Carbon Per Scope of Service and Specifications Locations as specified in Specifications.			\$ _____/HR	
3.	Labor: Complete Service to Remove / Replace, Inspect, Clean, and Dispose of Old Carbon Per Scope of Service and Specifications Additional potential locations as requested by the City.			\$ _____/HR	
TOTAL EXTENDED COST NOT TO EXCEED: (All costs must be <u>included</u> or Your Bid will be disqualified)				\$ _____	

ADDITION TO SPECIFICATIONS PAGE 4:

The Water and Sewer Department Management section reserves the right to make additions to or deletions from the specified locations by giving the Seller a seven (7) day written notice of intent. If the City determines that any site listed in this Bid Packet does not need service either temporarily or on a permanent basis, the Seller will delete that site from their area list and will not invoice the City for that site.

8/9/2024

INVITATION FOR BID TAC 1299

Addendum #1

Please note the following changes which have been made for clarification to this Invitation for Sealed Bid. **This addendum must be listed as Addendum #1 on the ACKNOWLEDGMENT OF RECEIPT OF ADDENDA/AMENDMENTS FORM** of the bid package as verification that you have received and are aware of the information contained herein.

QUESTIONS/CLARIFICATION/CHANGES:

CHANGES:

Was:

EVENT	DATE
IFB Issue Date	08/01/2024
Pre-Bid Conference 151 West 36 th Street North, Catoosa, OK 74015	08/13/2024 8:30 AM CDT
Deadline for Questions <i>Submitted to assigned buyer via email.</i>	08/19/2024 <i>10 Days prior to IFB due date</i>
Bid Submission Date <i>Either mailed or delivered to City Clerk address. Bids are open the day after the due date.</i>	08/28/2024

Changed to:

EVENT	DATE
IFB Issue Date	08/01/2024
Pre-Bid Conference #1 151 West 36 th Street North, Catoosa, OK 74015	08/13/2024 8:30 AM CDT
Pre-Bid Conference #2 151 West 36 th Street North, Catoosa, OK 74015	08/23/2024 8:30 AM CDT
Deadline for Questions <i>Submitted to assigned buyer via email.</i>	09/03/2024 <i>9 Days prior to IFB due date</i>
Bid Submission Date <i>Either mailed or delivered to City Clerk address. Bids are open the day after the due date.</i>	09/11/2024

Invitation for Bid (IFB)

TAC 1299

Supplies or Services Requested: Activated Carbon and Removal/Disposal

Department: Water and Sewer

NIGP Commodity Code(s): 885-08

Solicitation Schedule

EVENT	DATE
IFB Issue Date	08/01/2024
Pre-Bid Conference #1 151 West 36 th Street North, Catoosa, OK 74015	08/13/2024 8:30 AM CDT
Pre-Bid Conference #2 151 West 36 th Street North, Catoosa, OK 74015	08/23/2024 8:30 AM CDT
Deadline for Questions <i>Submitted to assigned buyer via email.</i>	09/03/2024 <i>9 Days prior to IFB due date</i>
Bid Submission Date <i>Either mailed or delivered to City Clerk address. Bids are open the day after the due date.</i>	09/11/2024

If You have any questions or need additional information, contact the Assigned Buyer:

Angie Tune, Senior Buyer | ATune@CityofTulsa.org
*All questions should be emailed with **TAC 1299** on the subject line.*

Submit Bids (sealed) to:

City of Tulsa – City Clerk’s Office
 175 E. 2ND St., Suite 260
 Tulsa, OK 74103

*Bids (2 total:1 original, 1 copy) must be sealed and either mailed or delivered. Write the Bid Number, Supplies or Service requested (as listed above), and Bid Opening Date on the lower left corner of the outside of Your Bid envelope. Feel free to use included packing slip. No faxed or emailed Bids will be considered. Barring certain circumstances (Section III-5), Bids received after the stated date and time **will not be accepted and will be returned to the Bidder unopened.***



CITY OF
Tulsa
 A New Kind of Energy.

I. STATEMENT OF PURPOSE:

1. Overview and Goals

The goal of this solicitation is to secure a source to purchase Activated Carbon and Removal/Disposal for the Water and Sewer Department of the City of Tulsa.

2. Term of Contract

The City intends to award a one-year annual contract. The City may offer the Seller the opportunity for additional one-year terms. The City also reserves the right to make multiple or partial awards. To do business with the City, You must agree to the terms and conditions of the City's standard Purchase Agreement, indicated by **Your Authorized Agent's** signature on the Purchase Agreement.

Capitalized terms used in this IFB and not defined in the Purchase Agreement shall have the meanings as ascribed to them in Title 6, Chapter 4 of the [Tulsa Revised Ordinances](#).

The entire Invitation for Bid (IFB), including any additional information submitted by Bidder and Accepted by City will be included as part of the Agreement between Seller and City. **All sheets of this IFB (including Sections I-VI) must be submitted.**

Authorized Agent

Several parts of the Bid (Affidavits, Purchase Agreement) must be signed by an “**Authorized Agent.**” An Authorized Agent means an agent who is legally authorized to bind the Seller under the law of the state in which the Seller is legally organized. **For instance, under Oklahoma law, the Authorized Agent for each of the following types of entities is as stated below:**

- **Corporations** – the president, vice president, board chair or board vice chair can sign; others can sign if they have and provide the City with (i) a corporate resolution giving them authority to bind the Seller, and (ii) a recent corporate secretary's certificate indicating the authority is still valid.
- **General Partnerships** – any partner can sign to bind all partners.
- **Limited Partnerships** – the general partner must sign.
- **Individuals** – no additional authorization is required, but signatures must be witnessed and notarized.
- **Sole Proprietorship** – the owner can sign. Any other person can sign if s/he provides a recent Power of Attorney, signed by the owner, authorizing him/her to bind the sole proprietorship.
- **Limited Liability Company (LLC)** – The manager as named in the Operating Agreement can sign. Any person authorized by the Operating Agreement or a member can sign providing the person submits a copy of the authorization with a certificate of the members indicating the authorization is still valid.

Entities organized in states other than Oklahoma must follow the law of the state in which they are organized.

II. SCOPE OF SERVICES AND SPECIFICATIONS

1. Scope of Services

The City is requesting Bids for a source to purchase Activated Carbon and Removal/Disposal for the Water and Sewer Department

Delivery Requirements

All prices quoted shall be based on delivery F.O.B. Tulsa, Oklahoma or to any other points as may be designated in the Specifications, with all charges prepaid by Seller to the actual point of delivery. Bids must state the number of Days required for delivery under normal conditions.

Absolutely no items over 500lbs. may be directly shipped to the City requiring the City personnel to unload from the shipping truck or trailer. The City carries no responsibility for any damages incurred during an unloading occurrence. All unloading shall be the responsibility of the Seller and/or shipping entity.

Project Scope:

This service will include:

- Remove and dispose the existing carbon media in the seven (7) odor control vessels. Photographs included in Specifications.
- Remove and dispose of any trash or debris inside each vessel.
- Power wash the bird screen on the bypass exhaust of each vessel to remove trash and debris.
- Install carbon media inside each vessel so that the bed in each vessel is approximately 3 feet deep or the required depth per Operations and Maintenance Manual.
- Provide Darco H2S LP Extruded Activate Carbon in 1,000 lb. bulk bags.
- The amount of carbon is based on an apparent (poured) density of 31 lbs. per cubic foot.
- Reinstall the access ports with the new gaskets that are suitable for the application.
- Replace screen.
- The Seller shall schedule the work in cooperation with City personnel to provide access.
- The Seller shall confine equipment and personnel within the boundaries of the identified work area during execution of the project.
- The Seller shall be responsible for selecting the appropriate licensed disposal facility to which the existing carbon media material will be delivered and will obtain any required waste disposal approval(s) from the disposal facility.
- **The Seller shall protect the existing amenities** of the site during the project and be held liable for any resulting damage. These amenities include, but are not limited to, buildings, pavement, walkways, curbing, equipment, and vegetation, including trees.
- The Seller shall perform a pre-final site inspection with City personnel before Seller's equipment and personnel are demobilized from the site. Assuming formal acceptance of work is granted, Seller's personnel will remove equipment, materials, and temporary facilities from the site. Equipment will be disassembled once no longer needed. Areas where construction activities occurred will be left in a clean and stable condition prior to fully demobilizing from the site (see photos attached pages 4 – 6).

2. Specifications

The Bid **must** meet or exceed the following Specifications.

- See attached photographs of the seven (7) odor control vessels to be serviced on pages 4 – 6.

- The Water and Sewer Department Management section reserves the right to make additions to or deletions from the specified locations by giving the Seller a seven (7) day written notice of intent. If the City determines that any site listed in this Bid Packet does not need service either temporarily or on a permanent basis, the Seller will delete that site from their area list and will not invoice the City for that site.



Cherry Creek: 4899 S Elwood Ave, Tulsa 74107



SE Lift Station: 12366 S Sheridan Rd, Bixby 74008



Haikey Creek: 11602 E 151st St S, Broken Arrow, OK 74011

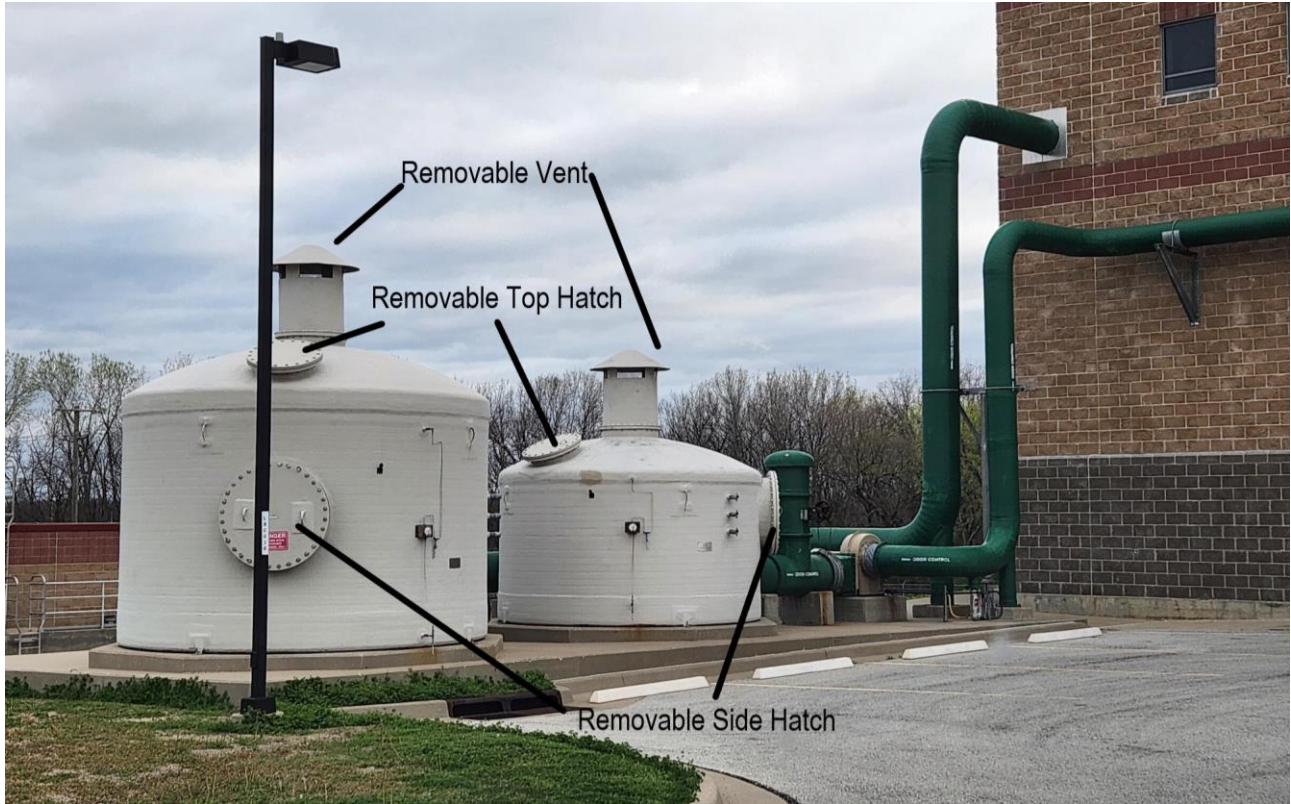

Lower Bird Creek: 151 W 36th St N, Catoosa, OK 74015



Spunky Creek: 151 W 36th St N, Catoosa, OK 74015

III. BID SUBMISSION INSTRUCTIONS AND INFORMATION

1. **Bidder Registration**: To ensure timely updates and alerts about business opportunities with the City, interested Bidders should register as a Bidder with the City. To register, interested Bidders should complete the City's online vendor registration form ([linked here](#)). If You have any questions regarding registration, email Cheryl Quin at purchasing@cityoftulsa.org or check the City's "[Selling to the City](#)" Website.

2. **Pre-Bid Conference**: If a Pre-Bid Conference is required, see the first page for time and location.

Attendance Requirement

Attendance at the Pre-Bid Conference is required to submit a Bid.

Pre-Bid Conference will begin at 151 West 36th Street North, Catoosa, OK 74015, then to 11602 East 151st Street South, Broken Arrow, OK 74011, ending at 5300 South Elwood Avenue, Tulsa, OK 74107

3. **Questions and Concerns**: As You prepare Your Bid response, You may have questions or points of clarification around this Solicitation. Any questions or comments about this Invitation for Bid must be sent via e-mail to the buyer listed on the first page "Assigned Buyer" and be received at least **10 Days prior to the Bid Submission Date**. Please include the IFB Bid number (as indicated on the title page) on all communications. Bidders may only communicate with the City through the Assigned Buyer – communication with other City staff could result in disqualification.

4. **Issuing of Addenda**: The City may addend or amend its IFB at any time before the Bid Submission Date. In addition to registering as a Bidder with the City, Bidders can check the "Purchasing Bid Opportunities & Results" page on the City Website for the latest updates ([linked here](#)). Any such amendments shall become a part of the Agreement. You must acknowledge receipt of any Addenda or Amendments by writing in the issued Addenda numbers on Exhibit A – Delivery and Pricing. City may reject any Bid that fails to acknowledge any Addenda or Amendments.

5. **Submission and Receipt of Bids**: The City requires two completed Invitation for Bids: 1 Original and 1 Copy. Each must be clearly labeled on the front sheet indicating "Original" or "Copy." Use the Bidder Checklist to ensure Your Bid includes all required components. If a copy on electronic media is also required, the box below will be checked.

Electronic Copy also required.

Bids must be received no later than 5:00 PM (CST) on the Bid Submission Date (see first page) and delivered to:

**City of Tulsa - City Clerk's Office
175 East 2nd Street, Suite 260
Tulsa Oklahoma 74103**

Bids must be sealed and either mailed or delivered. The package, container, or envelope should contain both of Your completed Bids, the original and the copy. Please use the provided label on the last page of this IFB to clearly write the Bidder's legal name and Bid number on the outside of the package, container, or envelope. No faxed or emailed Bids will be considered.

Bids received after the stated date and time **will not be accepted**. The timestamp clock located at the City Clerk's Office on the second floor of City Hall at 175 East 2nd Street, Suite 260, Tulsa,

Oklahoma, 74103 is the City's official bid clock for this IFB. Timeliness of Bid submittals will be determined using only this clock.

Exceptions to Timeliness Requirement

The Purchasing Agent, at his/her sole discretion, may make exceptions only for the following reasons:

- City Hall closed for business for part or all of the day on the date the response was due;
- If the Purchasing Agent deems it appropriate due to large-scale disruptions in supply chains and the transportation industry that may have prevented delivery as required;
- If documented weather conditions caused the late delivery. You must provide documentation of such weather to the satisfaction of the Purchasing Agent.

In the event that the Bid submittal is delivered after the time specified and does not meet the exceptions listed above, the Bid will not be accepted and the submittal envelope will not be opened.

The City will not be liable for delays in delivery of Bids to the City due to handling by the U.S. Postal Service, or any other type of delivery service. The City reserves the right to postpone the date and time for submittal of Bids at any time prior to the Bid Opening Date or to delay or reschedule the Bid Opening Date for its own convenience.

The City reserves the right to cancel, revise, or amend this IFB and associated bidding documents up to the time specified for receipt of Bids.

6. **Bid Opening**: All Bid openings are public and take place at 8:30 a.m. Thursday, the day after Bids are due. The Bid openings are held in the City of Tulsa Council Meeting Room, 175 East 2nd Street, 2nd Floor, Tulsa, Oklahoma.

IV. BID EVALUATION AND AWARD

1. **Bid Evaluation**: The Assigned Buyer and departmental staff will work together to determine the winning Bid. Generally speaking, the Bid award will go to the **Lowest Secure Bidder: the Supply or Service that can best meet the City's needs at the lowest cost.** In addition to price and specifications, the Buyer and departmental staff may also evaluate Bidder history and experience, delivery time, maintenance requirements, and performance data, among other factors.
2. **Bid Rejection or Withdrawal**: The City may reject any or all Bids in whole or in part. Reasons a Bid may be rejected include, but are not limited to the following:
 - A submitted Bid does not contain all the necessary materials, signatures, and/or affidavits (listed on the included checklist);
 - The Bid does not meet specifications and requirements in some material way;
 - The Bidder holds outstanding debt to the City;
 - The Bidder adds additional terms and conditions that modify IFB requirements or attempt to limit Bidder's liability to the City.

City reserves the right to waive minor deficiencies of specifications, technicalities or informalities in a Bid, provided that the best interest of the City would be served without prejudice to the rights of other Bidders. Bid withdrawal, meanwhile, may only be accomplished by having an Authorized Agent request the withdrawal in person at the City Clerk's office before the City's close of business on the Bid Submission Date.

3. **Bid Award Recommendation and Appeal**: Upon confirming the Bid recommended for selection, the Assigned Buyer will email all participating Bidders a memo announcing the recommended Bid. This email will also share the time, date, and virtual meeting link for the Standard, Specifications, and Award (SSA) committee meeting where the Bid award recommendation will be reviewed.

If approved by SSA, the award recommendation is then sent to the Mayor for the Mayor's final approval. SSA meetings are held Thursdays at 8:30am in the City of Tulsa Council Meeting Room, 175 East 2nd Street, 2nd Floor, Tulsa, Oklahoma. The meeting will be held on a given Thursday at 8:30 am, depending on when the Bid award has been determined. During this meeting, Bidders who are not recommended for award can issue an appeal and ask that the Bid award be reconsidered. Bidders who are not recommended for award can also email the Assigned Buyer prior to the SSA meeting if they have any questions or concerns regarding the award recommendation.

If/when the Bid award is approved by the SSA committee, the City will make available on the City's Purchasing Website a summary of Bids received generally within 5 working days after the Bid Opening Date. After a Bid award is recommended to the Mayor, a copy of the Bid summary will be available in the City Clerk's Office. Bid results are not provided in response to telephone or email inquiries. All Bid awards are subject to Acceptance by the City.

V. BID PROCESSING

- Forms, Notice to Proceed, and Irrevocability of Offer:** If the City Accepts Your Bid, You will have ten (10) Days from notification of the Acceptance to provide a completed IRS form W-9. You cannot start work until authorized to do so by the Purchasing Agent or a representative.

Bidder understands and acknowledges that the offer submitted as the Bid is firm and irrevocable from the City's close of business on the Bid Submission Date until the date the City Accepts the Bid or 365 Days after the Bid Opening Date, whichever is earlier.

- Purchase Order Without Contract:** If the successful Bid is less than One Hundred Thousand Dollars (\$100,000), the City, in its sole discretion, may Accept the Bid upon written approval of the Mayor rather than execute the Purchase Agreement. Instead, the City will purchase the Supplies and/or Services by issuing a purchase order. In any event, the terms of this IFB will govern the transaction and be enforceable by the City and Seller.

- Insurance:**

Yes: No:

Seller and its subcontractors must obtain at Seller's expense and keep in effect so long as City is purchasing Supplies or Services from Seller pursuant to this Bid, policies of insurance in the minimum amounts set forth below and Workers' Compensation and Employer's Liability insurance in the statutory limits required by law.

General Liability: personal injury and property damage, each occurrence	\$1,000,000.00
Automobile Liability: Combined Single Limit (CSL), each occurrence	\$1,000,000.00
Workers' Compensation	(Statutory limits)

Seller's insurer must be authorized to transact business in the State of Oklahoma. Seller will have 10 Days after notification that its Bid was Accepted by the City to provide proof of coverage.

The Certificate of Insurance must be completed with the following information:

- Your name
- Insurer's name and address
- Policy number
- Liability coverage and amounts
- Commencement and expiration dates
- Signature of authorized agent of insurer
- Certificate Holder Information: City of Tulsa, 175 East 2nd St., Suite 260, Tulsa, OK 74103

Seller shall not cause any required insurance policy to be cancelled nor permit it to lapse. Failure of the Seller to comply with the insurance requirements may be deemed a breach of the contract.

- Bonding:**

Yes: No:

5. **Federal Funding:** If the box is checked "Yes," federal funding is involved with this purchase:

Yes: No:

6. **References:** If the box is checked "Yes," References are **required:**

Yes: No: If yes, number of references required: 2

For each reference, the following information must be included: Company Name, Contact Name, Address, Phone Number, E-Mail Address, and the supplies or services provided.

Company Name:	_____
Contact Name:	_____
Address:	_____
Phone Number:	_____
Email Address:	_____
Description of Supplies/Services Provided:	_____
Company Name:	_____
Contact Name:	_____
Address:	_____
Phone Number:	_____
Email Address:	_____
Description of Supplies/Services Provided:	_____

EXHIBIT A – DELIVERY AND PRICING

Bidder’s Legal Name: _____
 (Must be Bidder’s company name as reflected on its organizational documents, filed with the state in which Bidder is organized)

Delivery: If Your Bid is Accepted, state the number of Days You need to deliver the Supplies and/or to begin providing Services: _____

You must be able to deliver the Supplies and/or Services as specified in Your Bid. Failure to do so may result in City terminating the Agreement and pursuing collection under any performance bond, as well as seeking any other damages to which it may be entitled in law or in equity.

Pricing:

Item	Description	Est Annual QTY	Unit Cost	Extended Cost	Manufacturer & Part Number
1.	Darco H2S LP	70,000 LBS.	\$	\$	
2.	Labor: Complete Service to Remove / Replace, Inspect, Clean, and Dispose of Old Carbon Per Scope of Service and Specifications Locations as specified in Specifications.			\$ _____/HR	
3.	Labor: Complete Service to Remove / Replace, Inspect, Clean, and Dispose of Old Carbon Per Scope of Service and Specifications Additional potential locations as requested by the City.			\$ _____/HR	

THE CITY DOES NOT GUARANTEE ANY SPECIFIC QUANTITY OR NUMBER OF PURCHASES, IF ANY, THAT WILL BE MADE DURING THE AGREEMENT TERM.

Annual Price Adjustment. The prices bid for any Supplies and/or Services shall not increase during the first year of the term of the Agreement. However, if You anticipate that You will not be able to maintain firm prices after the first year of the term, You may request an annual change in price using one of the following methods:

- a. The increase is limited to the change in the Consumer Price Index from BLS Table 1* (web link below) from the prior year
- b. Or the following fixed percentage: _____ %.

*Web Link: <https://www.bls.gov/news.release/cpi.t01.htm>

Addenda

The Bidder acknowledges receipt of Addenda to the IFB as follows. (Please write in each Addenda number issued, if applicable):

_____ Addenda # _____ Addenda # _____ Addenda # _____ Addenda # _____ Addenda #



State of Organization: _____

Bidder's Type of Legal Entity: (check one)

- | | |
|--|--|
| <input type="checkbox"/> Sole Proprietorship | <input type="checkbox"/> Limited Partnership |
| <input type="checkbox"/> Partnership | <input type="checkbox"/> Limited Liability Partnership |
| <input type="checkbox"/> Corporation | <input type="checkbox"/> Limited Liability Limited Partnership |
| <input type="checkbox"/> Limited Liability Company | <input type="checkbox"/> Other: _____ |

Bidder's Address: _____
Street City State Zip Code

Bidder's Website Address: _____

Sales Contact:

Name: _____
Title/Position: _____
Street: _____
City: _____
State: _____
Zip Code: _____
Phone: (____) _____
Email: _____

Contact for Legal Notice:

Name: _____
Title/Position: _____
Street: _____
City: _____
State: _____
Zip Code: _____
Phone: (____) _____
Email: _____

How did you learn about this business opportunity with the City of Tulsa?

- Email from Assigned Buyer
- City of Tulsa Website
- Tulsa World posting
- Purchasing search engine
- Industry colleague
- Other: _____

AFFIDAVIT
NON-COLLUSION, INTEREST, AND CLAIMANT

STATE OF _____)
)ss.
COUNTY OF _____)

I, _____, of lawful age, being first duly sworn, state that:
(Seller's Authorized Agent)

1. I am the Authorized Agent of Seller herein for the purposes of certifying facts pertaining to the existence of collusion between and among Bidders and municipal officials or employees, as well as facts pertaining to the giving or offering of things of value to government personnel in return for special consideration in the letting of any contract pursuant to the proposal to which this statement is attached.
2. I am fully aware of the facts and circumstances surrounding the making of Seller's Bid to which this statement is attached, and I have been personally and directly involved in the proceedings leading to the submission of such Bid; and
3. Neither the Seller nor anyone subject to the Seller's direction or control has been a party:
 - a. to any collusion among Bidders in restraint of freedom of competition by agreement to respond at a fixed price or to refrain from responding,
 - b. to any collusion with any municipal official or employee as to quantity, quality, or price in the prospective contract, or as to any other terms of such prospective contract, nor
 - c. in any discussions between Bidders and any municipal official concerning exchange of money or other thing of value for special consideration in the letting of a contract.
4. No officer or employee of the City of Tulsa either directly or indirectly owns a five percent (5%) interest or more in the Bidders business or such a percentage that constitutes a controlling interest. Affiant further states that the following officers and/or employees of the City of Tulsa own an interest in the Bidders business which is less than a controlling interest, either direct or indirect.

5. All invoices to be submitted pursuant to this agreement with the City of Tulsa will be true and correct.
6. That the work, services or material furnished will be completed or supplied in accordance with the plans, specifications, orders, requests or contract furnished or executed by the affiant. Affiant further states that (s)he has made no payment directly or indirectly to any elected official, officer or employee of the City of Tulsa or of any public trust where the City of Tulsa is a beneficiary, of money or any other thing of value to obtain payment of the invoice or procure the contract or purchase order pursuant to which an invoice is submitted. Affiant further certifies that (s)he has complied with all applicable laws regarding equal employment opportunity.

By: _____
Signature
Title: _____

Subscribed and sworn to before me this _____ day of _____, 20_____.

Notary Public

My Commission Expires: _____

Notary Commission Number: _____

The Affidavit must be signed by an Authorized Agent and notarized.



PURCHASE AGREEMENT

(Page 1 of 5)

INSTRUCTIONS: Bidder must properly sign and return this document or Bid may be **rejected**. Your signature on this document indicates You have read and understand these terms and conditions and agree to be bound by them.

THIS PURCHASE AGREEMENT is between the CITY OF TULSA, OKLAHOMA, a municipal corporation, 175 East 2nd Street, Tulsa, Oklahoma, 74103-3827 (the "City") and:

(Bidder's company name as reflected on its organizational documents filed with the state in which Bidder is organized; not simply DBA and address) (the "Seller").

WITNESSETH:

WHEREAS, the City has approved certain specifications and advertised for or solicited Bids on the following supplies or services:

TAC 1299 – Activated Carbon and Removal/Disposal

(the "Supplies and/or Services").

WHEREAS, Seller submitted a Bid and desires to provide the Supplies and/or Services to City;

WHEREAS, Seller acknowledges that its signature on this Purchase Agreement constitutes an irrevocable offer to provide the Supplies and/or Services specified in the Agreement and that if Accepted by the City's Mayor, this document will become the contract for such Supplies and/or Services.

NOW, THEREFORE, for and in consideration of the terms, covenants and conditions hereinafter set forth, the parties hereto agree as follows:

1. Definitions.

- 1.1. **"Acceptance" or "Accepts"** with respect to a Bid means either (1) City's execution of the Purchase Agreement, or (2) Mayor's written approval of the Bid award recommendation and issuance of a purchase order on behalf of the City if the purchase is for an amount less than One Hundred Thousand Dollars (\$100,000) and the City determines it is in its best interests.
- 1.2. **"Acceptance"** with respect to delivery of the Supplies and/or Services shall mean City's written acknowledgment that Seller has satisfactorily provided such Supplies and/or Services as required.
- 1.3. **"Addenda" "Addendum" or Amendment(s)"** means a clarification, revision, addition, or deletion to the Invitation for Bid by City which will become a part of the agreement between the parties.
- 1.4. **"Agreement"** consists of the Invitation for Bid and the Purchase Agreement.
- 1.5. **"Bid Opening Date"** means the date the Bid is opened by the City.
- 1.6. **"Bid Submission Date"** means the date the Bid is due from Bidder to the City.
- 1.7. **"City"** means the City of Tulsa, Oklahoma.
- 1.8. **"Days"** means calendar days unless otherwise specified.
- 1.9. **"Invitation for Bid" or "IFB"** consists of the following documents: Cover page, Sections I-VI, Exhibit A – Delivery and Pricing, Affidavit(s), Purchase Agreement, and Bidder Checklist.
- 1.10. **"Primary Seller"** means the Seller whose Bid City Accepts as the principal seller of the Supplies and/or Services required.
- 1.11. **"Purchasing Ordinance"** means Tulsa Revised Ordinances, Title 6, Chapter 4 et seq.
- 1.12. **"Secondary Seller"** means the Seller whose Bid City Accepts as a back-up seller in the event the Primary Seller is unable to provide all the Supplies and/or Services.
- 1.13. **"Seller"** means the Bidder whose Bid City Accepts.
- 1.14. **"Specifications"** means the technical and/or performance requirements for the Supplies or Services.
- 1.15. **"You" or "Your"** means the Bidder responding to this Invitation for Bid or the Seller whose Bid the City Accepts.
- 1.16. **"Website"** means the City of Tulsa's website for the Purchasing Division: www.cityoftulsa.org/purchasing

2. **Order of Precedence.** Capitalized terms used but not defined herein will have the respective meanings given to them in the Purchasing Ordinance. In the event of conflicting or ambiguous language between this Purchase Agreement, any of the other Agreement documents, and additional information submitted by the Seller and Accepted by City, the parties shall be governed first according to this Purchase Agreement, second according to the remainder of the documents included in the Agreement and third according to any additional information submitted by Seller and Accepted by City.

3. **Purchase and Sale.** Seller agrees to sell City the Supplies and/or Services for the price and upon the delivery terms set forth on Exhibit A – Delivery and Pricing. City agrees to pay Seller the price as set forth in Exhibit A based on (a) the quantity actually purchased in the case of Supplies and/or Services priced by unit, or (b) the total price for a stated quantity of Supplies and/or Services, upon (i) delivery of the Supplies and/or Services to the City, (ii) the City's Acceptance thereof, and (iii) Seller's submission and City's approval of a verified claim for the amount due. City shall not pay any late charges or fees.

PURCHASE AGREEMENT

(Page 2 of 5)

4. **Term.** The term of the Agreement begins on the date the Mayor/Mayor Pro Tem of the City of Tulsa executes this Purchase Agreement and terminates one year from that date. City in its sole discretion may offer Seller an opportunity to renew this Agreement up to an additional four (4) one (1) year term(s). Seller understands and acknowledges that any future contracts or renewals are neither automatic nor implied by this Agreement. City's continuing purchase of the Supplies and/or Services set forth in this Agreement is subject to City's needs and to City's annual appropriation of sufficient funds in City's fiscal year (July 1st to June 30th) in which City purchases Supplies and/or Services. In the event City does not appropriate or budget sufficient funds to perform this Agreement, this Agreement is null and void without further action by City.

The City may extend the Agreement for ninety (90) days beyond a final renewal term at the price and upon the delivery terms set forth on Exhibit A – Delivery and Pricing. The City, at its sole option and to the extent allowable by law, may choose to exercise subsequent ninety (90) day extensions upon the price and upon the delivery terms set forth on Exhibit A – Delivery and Pricing to facilitate the finalization of related terms and conditions of a new award or as needed for transition to a new Seller.

5. **Supplies Warranty.** With respect to all Supplies to be delivered under this Agreement, Seller warrants to City that such Supplies will be of good materials and workmanship and free from defects and will conform to the Specifications provided by City. In addition, Seller shall assure that the Supplies purchased hereunder are covered by all available and applicable manufacturers' warranties for such Supplies and expressly agrees that it will be responsible for performing all warranty obligations set forth in the Specifications for the Supplies.
6. **Services Warranty.** With respect to all Services to be performed under this Agreement, Seller warrants that it shall perform the Services using personnel of required skill, experience, and qualifications and in a professional and workmanlike manner in accordance with generally recognized industry standards for similar services and in accordance with the Specifications provided by City.
7. **Warranty Period.** Seller agrees that all warranties set forth herein will remain in effect for a period of one (1) year from the date City Accepts the Supplies and/or Services, or as specified in the Specifications, whichever is later. Seller shall not disclaim or otherwise limit the express warranties set forth herein.
8. **Warranty Remedies.** City shall notify Seller if any of the Supplies and/or Services fails to meet the warranties set forth above. If the failure is with Supplies, then Seller shall promptly correct, repair or replace such Supplies at its sole expense and/or if the failure is with a Service, then Seller shall promptly reperform such Service at Seller's sole expense. Notwithstanding the foregoing, if City determines that such Supplies and/or Services are defective or non-conforming within the first thirty (30) Days after the date of Acceptance by City, then Seller at City's option shall refund the entire purchase price, and, in the case of Supplies, City shall promptly return such Supplies to Seller. Seller shall pay all expenses related to the return of such Supplies to Seller.
9. **Rejection, Seller Bears Risk.** All Supplies and Services purchased in the Agreement are subject to approval by the City. Rejection of Supplies or Services, resulting because of nonconformity to the terms, conditions, and Specifications of this Agreement, whether held by the City or returned, will be at Seller's risk and expense. Seller shall bear the risk of loss or damage at all times until the Acceptance of the Supplies or Services by City.
10. **Force Majeure.** Seller will not be responsible for delays in delivery of the Supplies or Services due to acts of God, government action or inaction, fire, war, or riot, provided Seller notifies the City immediately, in writing of such pending or actual delay. Normally, in the event of any such delays (acts of God, etc.) the date of delivery of the Supplies or Services will be extended for a period equal to the time lost due to the reason for delay.
11. **Conflict of Interest.** By signing this Purchase Agreement, Seller covenants that it has no direct or indirect pecuniary or proprietary interest, and that it shall not acquire an interest that conflicts in any manner or degree with the Supplies or Services required to be provided or performed under the Agreement. Furthermore, Seller shall not employ any person or agent having any such conflict of interest. In the event that the Seller or its agents, employees or representatives hereafter acquires such a conflict of interest, it shall immediately disclose such interest to the City and take action immediately to eliminate the conflict or to withdraw from this contract, as the City requests.
12. **No Indemnification by City.** Seller understands and acknowledges that City is a municipal corporation that is funded by its taxpayers to operate for the benefit of its citizens. Accordingly, and pursuant to Oklahoma law, City shall not indemnify nor hold Seller harmless for loss, damage, expense or liability arising from or related to this Agreement, including any attorneys' fees and costs. In addition, Seller shall not limit its liability to City for actual loss or direct damages for any claim based on a material breach of this Agreement. City reserves the right to pursue all legal and equitable remedies to which it may be entitled.
13. **Liability/Indemnification.** Seller shall hold City harmless for any loss, damage or claims arising from or related to its performance of the Agreement. Seller must exercise all reasonable and customary precautions to prevent any harm or loss to all persons and property related to the Agreement. Seller agrees to indemnify and hold the City harmless from all claims, demands, causes of action or suits of whatever nature arising out of the Supplies, Services, labor, or materials furnished by Seller or Seller's subcontractors under this Agreement. In addition, Seller agrees to indemnify, defend, and save harmless City and its officers, employees and agents from all suits and actions of any nature brought against them due to the use of patented appliances, products or processes provided by Seller hereunder. Seller shall pay all royalties and charges incident to such patents.

PURCHASE AGREEMENT

(Page 3 of 5)

14. **No liens.** Pursuant to City's Charter (Art. XII, §5), no lien of any kind shall exist against any property of City. Seller shall deliver all Supplies to City free and clear of liens. Delivery by Seller to City of Supplies which are subject to liens shall be a material breach of the Agreement and all damages and costs incurred by City because of the existence of such liens shall be paid to City by Seller. At City's option, City may return such Supplies to Seller and Seller shall pay the cost of returning such Supplies and reimburse City for any payments made for such Supplies.
15. **No Insurance by City.** If City is leasing Supplies herein, City shall not be required to obtain insurance for Seller's property. Seller shall be solely responsible for any insurance it deems necessary. City is self-insured for its own negligence, subject to the limits of the Governmental Tort Claims Act (51 O.S. § 151 et seq.).
16. **No Confidentiality.** Seller understands and acknowledges that City is subject to the Oklahoma Open Records Act (51 O.S. §24A.1 et seq.) and therefore cannot assure the confidentiality of this Agreement or other information provided by Seller pursuant to this Agreement that would be inconsistent with City's compliance with its statutory requirements thereunder.
17. **Compliance with Laws.** Seller shall comply, and ensure its subcontractors used in the performance of this Agreement comply with all applicable federal, state and local laws, regulations and standards. Seller is responsible for any costs of such compliance. Seller certifies that it and all its subcontractors to be used in the performance of this Agreement are in compliance with 25 O.S. Sec. 1313 and participate in the Status Verification System. The Status Verification System is defined in 25 O.S. Sec. 1312 and includes but is not limited to the free Employee Verification Program (E-Verify) available at www.dhs.gov/E-Verify.
18. **Termination.** City, by written notice, may terminate this Agreement, in whole or in part, when such action is in the best interest of City. If City terminates this Agreement, City shall be liable only for payment for Supplies accepted and Services rendered prior to the effective date of termination. City's right to terminate this Agreement is cumulative to any other rights and remedies provided by law or by this Agreement.
19. **Payment.** Invoices should be e-mailed to the City of Tulsa – Accounts Payable at: apinvoices@cityoftulsa.org. Payment will be made net 30 days after receipt of a properly submitted invoice or the City's Acceptance of the Supplies or Services, whichever is later.

Each invoice must be fully itemized, identifying Supplies provided and/or Services performed, and must bear the purchase order number assigned by the City.

The purchase order number shall appear on all invoices, packing lists, packages, shipping notices, instruction manuals and other written documents relating to the Supplies or Services. Packing lists shall be enclosed in each and every box or package shipped pursuant to this Agreement, indicating the content therein.

20. **Price Changes.** The parties understand and agree that the variables in Seller's cost of performance may fluctuate, but any change in Seller's cost of performance will not alter its obligations under this Agreement, nor excuse performance or delay on Seller's part. Notwithstanding the foregoing, after the first year of the term, the Seller may request a price increase in addition to any other price increase set forth in this Agreement. In its sole discretion, the City may approve the request if it determines that such price increase is in the City's best interest.
21. **Right to Audit.** Seller agrees that Seller's books, records, documents, accounting procedures, practices, price lists or any other items related to the Supplies and/or Services provided hereunder are subject to inspection, examination, and copying by City or its designees. City requires Seller to retain all records related to this Agreement for the duration of the term of this Agreement and a period of three years following completion and/or termination of the Agreement. If an audit, litigation or other action involving such records begins before the end of the three-year period, Seller shall maintain the records three years after the date that all issues arising out of the action are resolved or until the end of the three-year retention period, whichever is later.
22. **Notice.** Any notice, demand, or request required by or made pursuant to this Agreement will be deemed properly made if personally delivered in writing or deposited in the United States mail, postage prepaid, to the following:

To Seller:	To CITY:	Contact for Legal Notice as specified on Exhibit A – Delivery and Pricing form. City Clerk CITY OF TULSA, OKLAHOMA 175 E. 2 nd Street, Suite 260 Tulsa, Oklahoma 74103
	With a copy to:	Tulsa Purchasing Division 175 E. 2 nd Street, 15 th Floor Tulsa, OK 74103
23. **Relationship of Parties.** The Seller is and shall always remain an independent contractor with respect to activities and conduct while engaged in the performance of services for the City under this Agreement. No employees, subcontractors or agents of the Seller will be deemed to be employees of the City for any purpose whatsoever, and none will be eligible to participate in any benefit program provided by the City for its employees. The Seller shall be solely responsible for the payment

PURCHASE AGREEMENT

(Page 4 of 5)

of all employee wages and salaries, taxes, withholding payments, fringe benefits, insurance premiums, continuing education courses, materials or related expenses on behalf of its employees, subcontractors, and agents. Nothing in this Agreement will be construed to create a partnership, joint venture, or agency relationship among the parties. No party will have any right, power or authority to act as a legal representative of another party, and no party will have any power to obligate or bind another party, or to make any representations, express or implied, on behalf of or in the name of the other in any manner or for any purpose whatsoever.

24. **Third Parties.** This Agreement is between City and Seller and creates no right unto or duties to any other person. No person is or will be deemed a third-party beneficiary of this Agreement.
25. **Time of Essence.** City and Seller agree that time is deemed to be of the essence with respect to this Agreement. The Agreement is subject to cancellation by the City for Seller's failure to deliver on time. All deliveries are required F.O.B to the City's facilities. For any exception to the delivery date specified in the Agreement, Seller shall give prior written notification and obtain written approval from the City. The Acceptance by the City of later performance with or without objection or reservation shall neither waive the City's right to claim damages for such breach nor constitute a waiver of the requirements for the timely performance of any obligation remaining to be performed by Seller.
26. **Binding Effect.** This Agreement shall be binding upon City and Seller and their respective successors, heirs, legal representatives and permitted assigns.
27. **Headings.** The headings used herein are for convenience only and will not be used in interpreting this Agreement.
28. **Severability Provision.** If any term or provision herein is determined to be illegal or unenforceable, the remainder of this Agreement will not be affected thereby. It is the intention of the parties that if any provision is held to be illegal, invalid or unenforceable, there will be added in lieu thereof a provision as similar in terms to such provision as is possible to be legal, valid and enforceable.
29. **Governing Law and Venue.** This Agreement is executed in and shall be governed by and construed in accordance with the laws of the State of Oklahoma without regard to its choice of law principles, which shall be the forum for any lawsuits arising under this Agreement or incident thereto. The parties stipulate that venue is proper in a court of competent jurisdiction in Tulsa County, Oklahoma and each party waives any objection to such venue. City does not and will not agree to binding arbitration of any disputes.
30. **No Waiver.** A waiver of any breach of any provision of this Agreement shall not constitute or operate as a waiver of any other provision, nor shall any failure to enforce any provision hereof operate as a waiver of the enforcement of such provision or any other provision.
31. **Entire Agreement.** The entire agreement between City and Seller is contained in the Agreement. No verbal agreement between the parties is binding. Any scope of services, scope of work, quote, invoice, acknowledgment or other communication or other document issued by Seller in connection with this Agreement will be for the purposes of describing in greater detail the Supplies and/or Services (as applicable) to be provided. Seller's rejection or modification of the terms set forth in the City's IFB is void and of no effect, unless any such modification improves upon the City's terms or Specifications, in which case the improvement is accepted. Seller understands and acknowledges that if it adds terms and conditions to its Bid that are different from the terms set forth herein that City may reject the Bid as non-responsive.
32. **Amendment/No Assignment.** The Agreement may only be modified or amended in a writing signed by both parties. Notwithstanding anything to the contrary stated herein or in the attachments to this Agreement, no future agreements, revisions or modifications that may be required under this Agreement are effective or enforceable unless such terms, revisions or modifications have been reduced to writing and signed by City and Seller. Seller may not assign this Agreement or use subcontractors to provide the Supplies and/or Services without City's prior written consent. Seller shall not be entitled to any claim for extras of any kind or nature.
33. **Multiple Counterparts.** This Purchase Agreement may be executed in several counterparts, each of which will be deemed an original, but which together will constitute one and the same instrument.
34. **Interpretive Matters and Definitions.** The following interpretive matters shall be applicable to this Agreement:
 - 34.1. Unless the context otherwise requires: (a) all references to Sections are to Sections of or to this Agreement; (b) each term defined in this Agreement has the meaning assigned to it; (c) "or" is disjunctive but not necessarily exclusive; (d) words in a singular include the plural and vice versa. All references to "\$" or to dollar amounts shall be in lawful currency of the United States of America;
 - 34.2. No provision of this Agreement will be interpreted in favor of, or against, any of the parties hereto by reason of the extent to which such party or its counsel participated in the drafting thereof or by reason of the extent to which any such provision is inconsistent with any prior draft hereof or thereof;
 - 34.3. Any reference to any applicable laws will be deemed to include all rules and regulations promulgated thereunder and judicial interpretations thereof, unless the context requires otherwise;

PURCHASE AGREEMENT

(Page 5 of 5)

- 34.4. The word “including” means “including, without limitation” and does not limit the preceding words or terms; and
- 34.5. All words used in this Agreement will be construed to be of such gender, number or tense as circumstances require.
35. **Equal Employment Opportunity.** Seller agrees to comply with all applicable laws regarding equal employment opportunity and nondiscrimination.
36. **Authority to Bind.** The undersigned individual states that s/he has authority to bind Seller to this Agreement, that s/he has read and understands the terms of this Agreement, and that Seller agrees to be bound by this Agreement.

IMPORTANT NOTE: This document must be signed by Authorized Agent. FAILURE TO SUBMIT PROPERLY AUTHORIZED SIGNATURE MAY RESULT IN YOUR BID BEING REJECTED AS NONRESPONSIVE.

IN WITNESS WHEREOF, this Agreement has been executed in multiple copies on the dates set forth below to be effective during the period recited above.

Seller Company Name: _____

Sign Here ► _____

ATTEST:

Printed Name: _____

Title: _____

Corporate Secretary

Date: _____

**CITY OF TULSA, OKLAHOMA,
a municipal corporation,**

ATTEST:

By: _____

Mayor

City Clerk

Date: _____

APPROVED:

Assistant City Attorney

BIDDER CHECKLIST

Use this checklist to ensure You have properly read and completed **all** documents listed below. This document (the IFB) contains all the following materials, which must be completed and returned to the City of Tulsa City Clerk’s Office in a mailed envelope with the affixed packing label (found on the last page). Each of these documents will form the resulting Agreement between the City and Seller.

Remember: Bids must be sealed and either mailed or delivered. Please use the provided label to clearly write the Bidder legal name and Bid number on the outside of the package, container, or envelope. The package, container, or envelope should contain both of Your completed Bids, the original and the copy. No faxed or emailed Bids will be considered. Unless otherwise stated herein, Bids received after the stated date and time **will not be accepted**.

Bidder’s Name: _____

BIDDER CHECKLIST		
BIDDER DOCUMENTS	PAGES	INCLUDED?
Notice of Invitation for Bid (Cover page and Sections I-IV)	5-6, 11-13	
Specifications	7-10	
Certificate of Insurance	14	
References (if applicable)	15	
EXHIBIT A: Delivery and Pricing	16-17	
Affidavits Signatures of Authorized Agent and notarization required	18	
Purchase Agreement Complete legal name in first paragraph and signature block. Signature by Authorized Agent required.	19-23	

PACKING LABEL

Top Left Corner

Your Company Name

Street Address

City, State, Zip Code

FROM:

City of Tulsa – City Clerk’s Office

175 East 2nd Street, Suite 260

Tulsa, OK, 74103

Bidder Submission For:

BID# TAC 1299

BID DESCRIPTION: Activated Carbon and Removal/Disposal

Please affix this label on the package, container, or envelope containing Your two completed Bids: one labeled “Original,” the other labeled “Copy.” We recommend that both Bids (original and copy) be sent in the same envelope.

This label is designed to assist Your Bid in getting to the correct office (City Clerk’s) and that it is associated with the correct Solicitation (indicated by the Bid number). Bids must be sealed and either mailed or delivered to the City Clerk’s Office. Bids must also be received no later than 5:00 PM (CST) on date listed on the first page of the IFB.

EQUIPMENT AND PIPING SCHEDULES

WAFER BUTTERFLY VALVE SCHEDULE

ANTERO #	LOCATION	STATUS	SIZE	FITTINGS	OPERATOR	SPECIFICATION SECTION
VAL01	OCF-01 & OCF-02 HEADER	NEW	36"	FLANGE	GEARED OPERATOR W/ HANDWHEEL	-
VAL08	CARBON AIR UNIT CAU-01	NEW	24"	FLANGE	ELECTRICAL OPERATOR, 120V	17271
VAL09	CARBON AIR UNIT CAU-01	NEW	24"	FLANGE	ELECTRICAL OPERATOR, 120V	17271
VAL02	OCF-01 INFLUENT	NEW	36"	FLANGE	GEARED OPERATOR W/ HANDWHEEL	-
VAL10	CARBON AIR UNIT CAU-02	NEW	24"	FLANGE	ELECTRICAL OPERATOR, 120V	17271
VAL11	CARBON AIR UNIT CAU-02	NEW	24"	FLANGE	ELECTRICAL OPERATOR, 120V	17271
VAL03	OCF-02 INFLUENT	NEW	36"	FLANGE	GEARED OPERATOR W/ HANDWHEEL	-
VAL04	OCF-01 EFFLUENT	NEW	36"	FLANGE	GEARED OPERATOR W/ HANDWHEEL	-
VAL05	OCF-02 EFFLUENT	NEW	36"	FLANGE	GEARED OPERATOR W/ HANDWHEEL	-
VAL06	CARBON AIR UNIT CAU-01	NEW	36"	FLANGE	GEARED OPERATOR W/ HANDWHEEL	-
VAL07	CARBON AIR UNIT CAU-02	NEW	36"	FLANGE	GEARED OPERATOR W/ HANDWHEEL	-

ODOR CONTROL PIPING SCHEDULE

MARK	STATUS	TYPE	JOINT	SIZE	LINE DESCRIPTION	COLOR
OC-400	NEW	FRP	PE/PE	36"	EXHAUST TO CAU-02	GR
OC-401	NEW	FRP	PE/PE	24"	EXHAUST FROM CARBON AIR UNIT CAU-02 TO ATMOSPHERE	WT
OC-402	NEW	FRP	PE/PE	24"	EXHAUST FROM CARBON AIR UNIT CAU-02 TO ATMOSPHERE	WT
OC-403	NEW	FRP	PE/PE	20"	INTAKE TO WETWELL	GR
OC-404	NEW	FRP	PE/PE	24"	EXHAUST FROM CARBON AIR UNIT CAU-01 TO ATMOSPHERE	WT
OC-405	NEW	FRP	PE/PE	24"	EXHAUST FROM CARBON AIR UNIT CAU-01 TO ATMOSPHERE	WT
OC-406	NEW	FRP	PE/PE	36"	INTAKE HEADER TO OCF-01 & OCF-02	GR
OC-407	NEW	FRP	PE/PE	36"	INTAKE TO OCF-02	GR
OC-408	NEW	FRP	PE/PE	36"	INTAKE TO OCF-01	GR
OC-409	NEW	FRP	PE/PE	36"	EXHAUST FROM OCF-02	GR
OC-410	NEW	FRP	PE/PE	36"	EXHAUST FROM OCF-01	GR
OC-411	NEW	FRP	PE/PE	42"	EXHAUST HEADER FROM OC-409 & OC-410	GR
OC-412	NEW	FRP	PE/PE	36"	EXHAUST TO CAU-01	GR
OC-413	NEW	FRP	PE/PE	20"	INTAKE TO WETWELL	GR

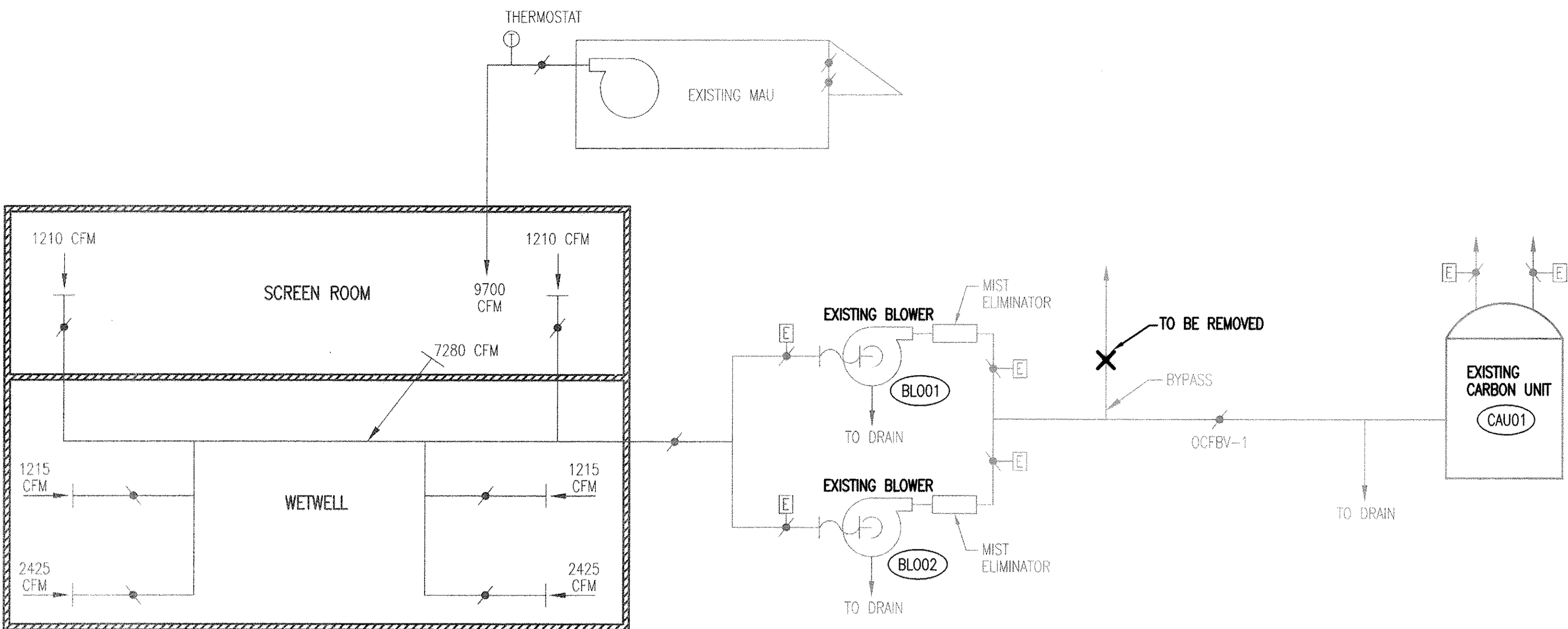

EXISTING ODOR CONTROL SYSTEM SCHEMATIC
NO SCALE

LEGEND

- EXISTING PIPING
- PROPOSED PIPING
- DENOTES CONNECTION TO EXISTING PIPE
- DIRECTION OF FLOW
- EXISTING ODOR CONTROL DAMPER WITH ELECTRIC ACTUATOR
- PROPOSED ODOR CONTROL DAMPER WITH ELECTRIC ACTUATOR
- EXISTING ODOR CONTROL DAMPER
- PROPOSED ODOR CONTROL DAMPER
- 30" OC-8 ODOR CONTROL PIPE DESIGNATION
- EXISTING STRUCTURE WALL
- DENOTES EQUIPMENT REMOVAL

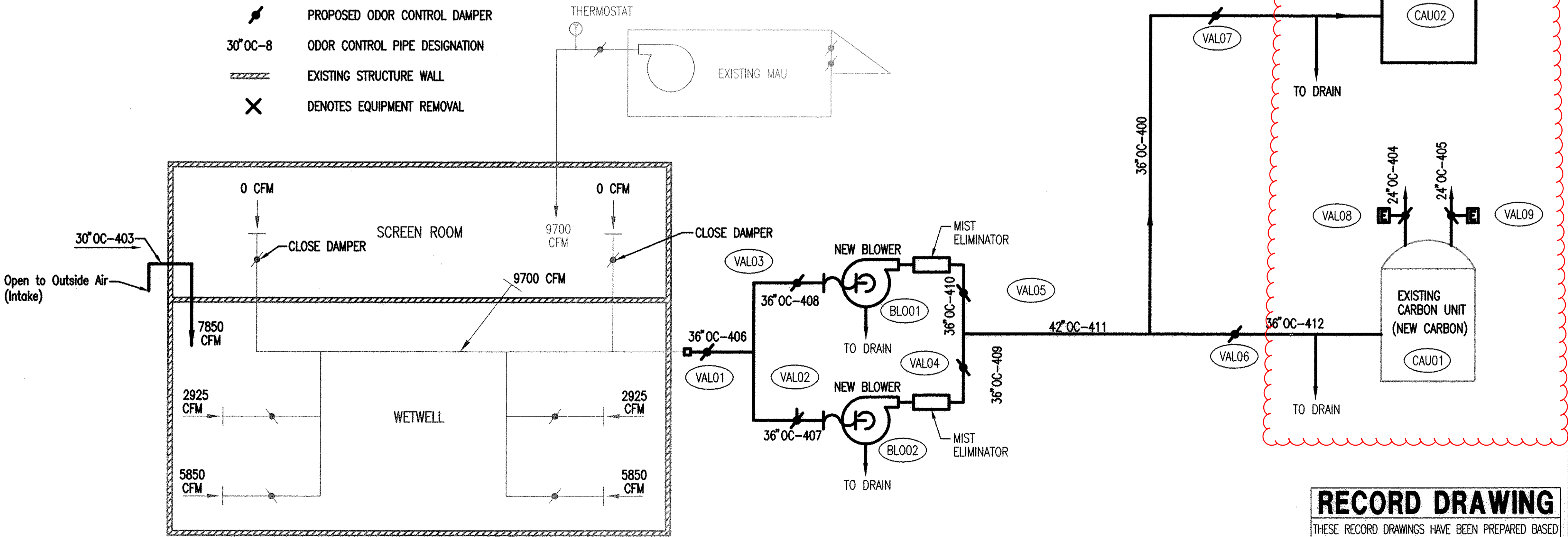

PROPOSED ODOR CONTROL SYSTEM SCHEMATIC
NO SCALE

PIPE LEGEND
FRP - FIBERGLASS REINFORCED PLASTIC

COLOR LEGEND
GR - GREEN
WT - WHITE

BLOWER SCHEDULE

ANTERO #	STATUS	CAPACITY	SPECIFICATION SECTION	HP	ELEC.
BLO01	NEW *	9,700 CFM	15780	30	480/60/3
BLO02	NEW *	9,700 CFM	15780	30	480/60/3

* UNITS TO BE NEW YORK BLOWER MODEL FRP FEG05589-100/115

CARBON UNIT SCHEDULE

ANTERO #	IDENTIFIER	STATUS	CAPACITY
CAU01	S104-LFT1-CAU01	EXISTING	11,025 CFM
CAU02	S104-LFT1-CAU02	REHABILITATED	11,025 CFM



EXISTING UNDERGROUND LINES HAVE BEEN SHOWN TO THE EXTENT KNOWN AND PLANS HAVE BEEN SENT TO THE AFFECTED UTILITY OWNERS FOR VERIFICATION OF EXISTING LINES. BEFORE YOU DIG, CALL OKIE: 1-800-522-6543.

RECORD DRAWING

THESE RECORD DRAWINGS HAVE BEEN PREPARED BASED ON INFORMATION PROVIDED BY OTHERS. THE ENGINEER HAS NOT VERIFIED THE ACCURACY OF THIS INFORMATION AND SHALL NOT BE RESPONSIBLE FOR ANY ERRORS OR OMISSIONS WHICH MAY BE INCORPORATED HEREIN AS A RESULT.
John J. Edwards July 8, 2013

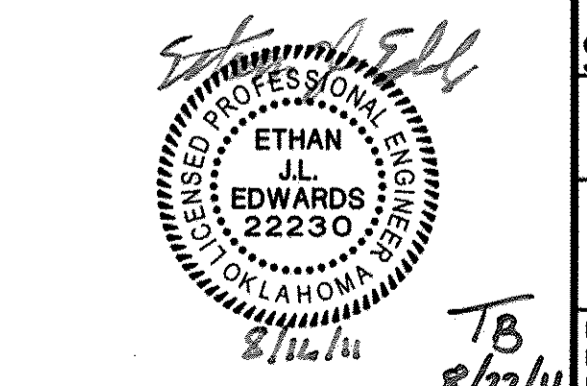

CHERRY CREEK LIFT STATION ODOR CONTROL SCHEMATICS, PIPING & EQUIPMENT SCHEDULES

CHERRY CREEK LIFT STATION IMPROVEMENTS
PROJECT NUMBER: SA 05-01
CITY OF TULSA, OKLAHOMA
PUBLIC WORKS DEPARTMENT
ENGINEERING SERVICES DIVISION

PLANS AND ESTIMATES PREPARED BY:	Professional Engineering Consultants, P.A. CHEROKEE BUILDING - 4150 SOUTH 100th EAST AVENUE, SUITE 401 TULSA, OKLAHOMA 74146 • 918-664-6400 • FAX 918-664-0200
DATE:	8/22/11
PREPARED BY:	ETHAN J. EDWARDS REGISTERED PROFESSIONAL ENGINEER STATE OF OKLAHOMA 22230
REVISION	BY DATE
PLAN SCALE:	DRAWN DESIGNED SURVEY
PROFILE SCALE:	FIELD MGR. <i>TJB</i> <i>8/11</i>
HORIZONTAL:	SECT. MGR. <i>WAS</i> <i>8/11</i>
VERTICAL:	PROJ. MGR. <i>EBW</i> <i>8/22/11</i>
RECOMMENDED:	DEPUTY DIRECTOR
FILE:	DRAWING: C4.0
DATE:	AUGUST, 2011
ATLAS PAGE NO:	SHEET 10 OF 22 SHEETS

Saved 08-15-2011 3:11:30 PM by EMC
 C:\PROJECTS\CHERRY_CREEK_ODOR_CONTROL_SCHEMATICS\CHERRY_CREEK_ODOR_CONTROL_SCHEMATICS.dwg
 1:4:45 PM by RUSSELL WIELLS
 C:\PROJECTS\CHERRY_CREEK_ODOR_CONTROL_SCHEMATICS\CHERRY_CREEK_ODOR_CONTROL_SCHEMATICS.dwg

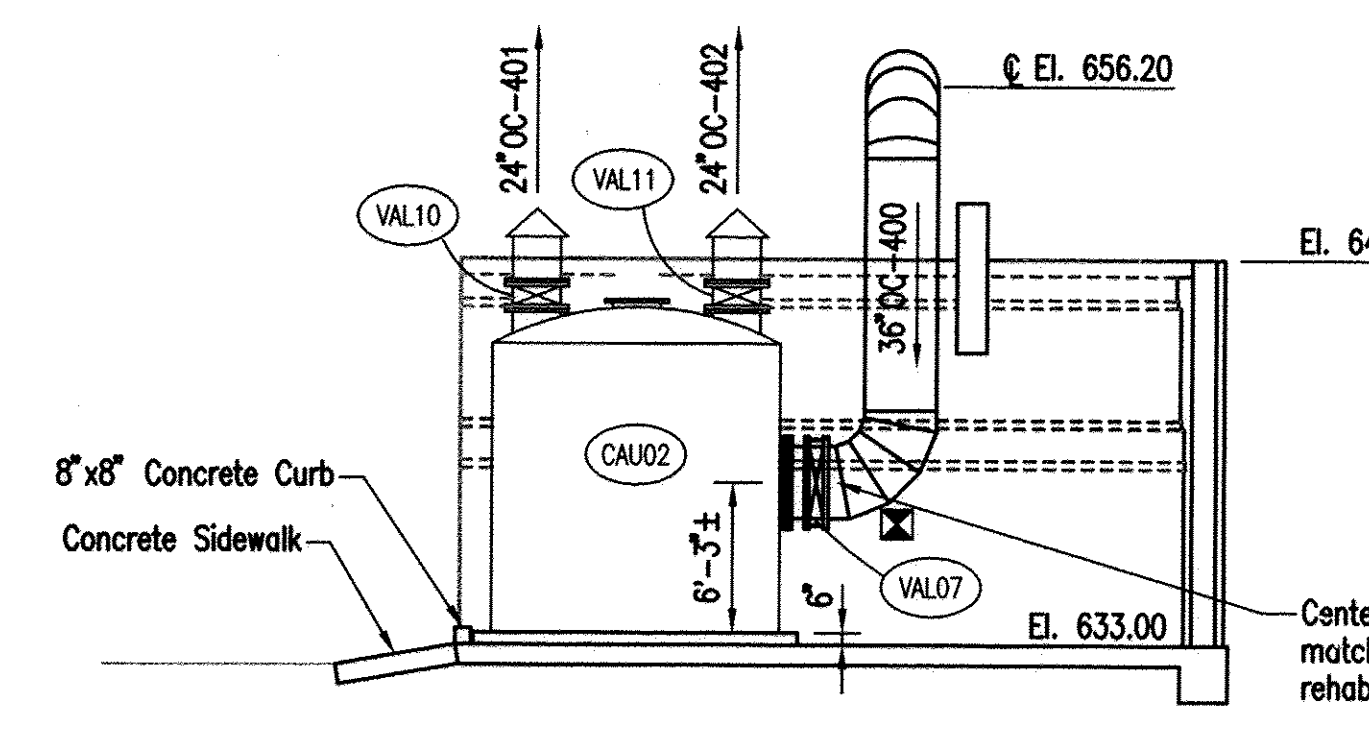
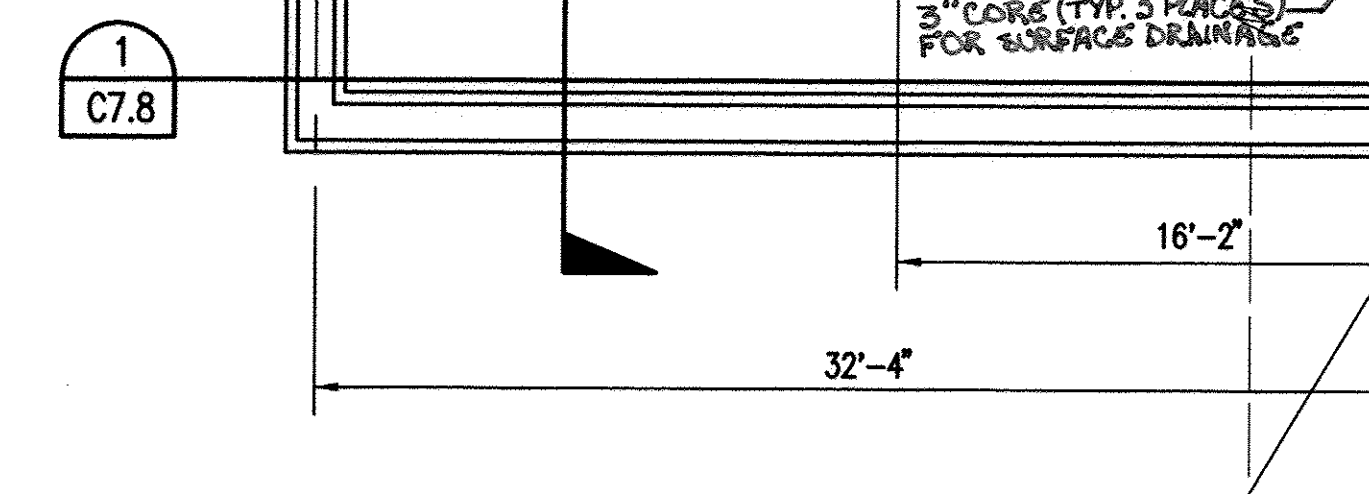
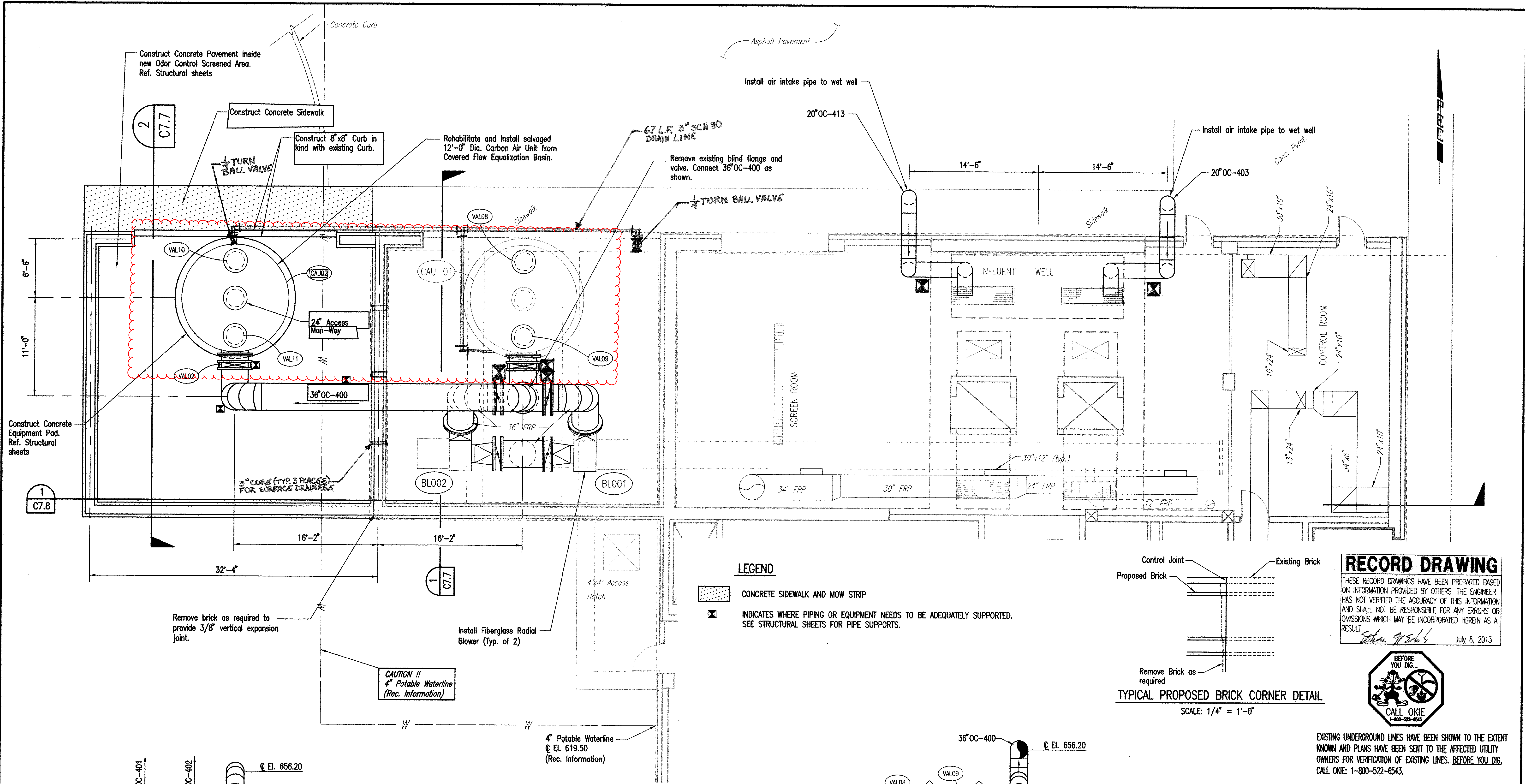

LEGEND

- CONCRETE SIDEWALK AND MOW STRIP
- INDICATES WHERE PIPING OR EQUIPMENT NEEDS TO BE ADEQUATELY SUPPORTED. SEE STRUCTURAL SHEETS FOR PIPE SUPPORTS.

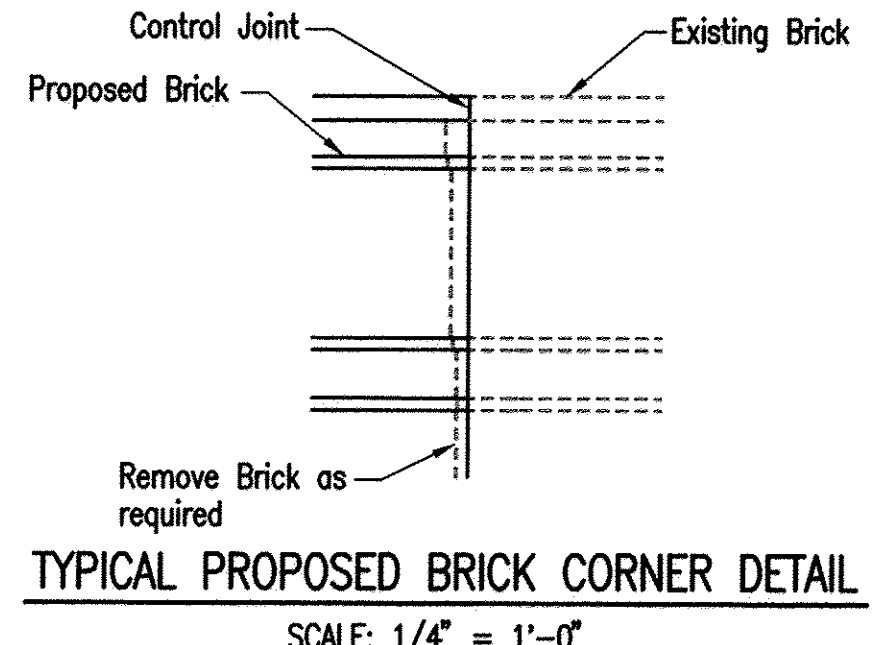

RECORD DRAWING
 THESE RECORD DRAWINGS HAVE BEEN PREPARED BASED ON INFORMATION PROVIDED BY OTHERS. THE ENGINEER HAS NOT VERIFIED THE ACCURACY OF THIS INFORMATION AND SHALL NOT BE RESPONSIBLE FOR ANY ERRORS OR OMISSIONS WHICH MAY BE INCORPORATED HEREIN AS A RESULT.
Ethan J. Edwards
 July 8, 2013



EXISTING UNDERGROUND LINES HAVE BEEN SHOWN TO THE EXTENT KNOWN AND PLANS HAVE BEEN SENT TO THE AFFECTED UTILITY OWNERS FOR VERIFICATION OF EXISTING LINES. **BEFORE YOU DIG, CALL OKIE: 1-800-822-6543.**

EXISTING LIFT STATION FLOOR PLAN (OPERATING)

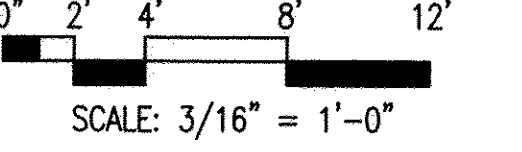

- NOTE TO CONTRACTOR:**
1. CONTRACTOR SHALL REMOVE ALL EQUIPMENT AND THAT PORTION OF STRUCTURES DESIGNATED TO BE DEMOLISHED UNLESS NOTED OTHERWISE. DEMOLITION PLANS PROVIDED REFLECT BEST AVAILABLE INFORMATION. CONTRACTOR SHALL COMPLETE DEMOLITION WORK ON STRUCTURES AND EQUIPMENT AS THEY EXIST FOR THE LUMP SUM PRICE BID FOR PROJECT IMPROVEMENTS. ALL EQUIPMENT REMOVED SHALL BE DISPOSED OF OFF-SITE UNLESS DIRECTED OTHERWISE.
 2. CONTRACTOR TO FIELD VERIFY DIMENSIONS AND LOCATIONS OF EXISTING EQUIPMENT. CONTRACTOR TO ADJUST EQUIPMENT AND PIPING AS REQUIRED TO FIT EXISTING CONDITIONS AT NO ADDITIONAL COST TO THE OWNER.
 3. REMOVE AND DISPOSE OF CARBON FROM CAU-01.
 4. PROVIDE NEW CARBON MEDIA FOR CAU-01 AND CAU-02.
 5. INSTALL BUG SCREEN TO OUTDOOR END OF AIR INTAKE PIPE.

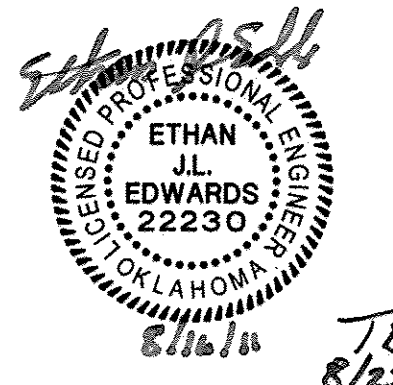
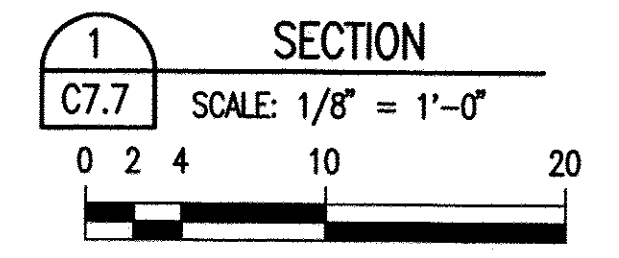
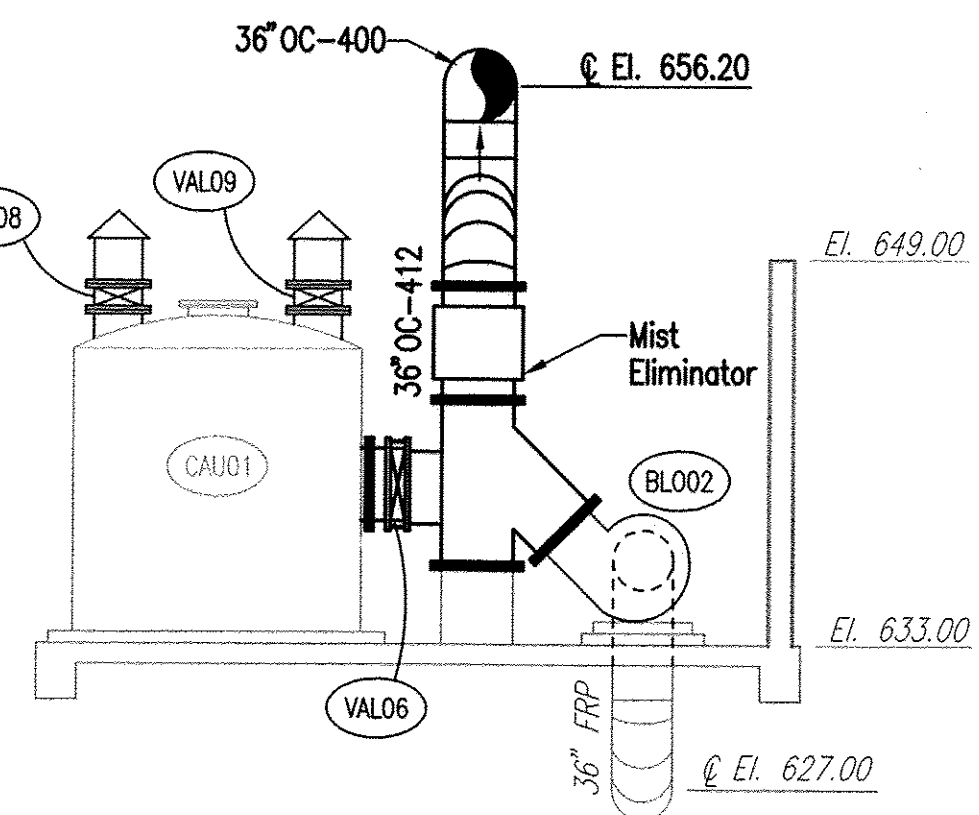

CHERRY CREEK LIFT STATION OPERATING FLOOR IMPROVEMENT PLAN AND SECTIONS

CHERRY CREEK LIFT STATION IMPROVEMENTS
 PROJECT NUMBER: SA 05-01
 CITY OF TULSA, OKLAHOMA
 PUBLIC WORKS DEPARTMENT
 ENGINEERING SERVICES DIVISION

PLANS AND ESTIMATES PREPARED BY: Professional Engineering Consultants, P.A.

REVISION	BY	DATE	PLAN SCALE:	DRAWN	DESIGNED	SURVEY	APPROVED:

PROFILE SCALE: FIELD MGR: *TJS* 8/11
 HORIZONTAL: SECT. MGR: *HAS* 8/11
 VERTICAL: RECOMMENDED: *TJV* 8/13/11
 DEPUTY DIRECTOR

FILE: DRAWING: C4.1 DATE: AUGUST, 2011
 ATLAS PAGE NO: SHEET 11 OF 22 SHEETS

Saved: 08-15-2011 3:36:38 PM by: EMC
 Plot Scale: 1:1 08-16-2011 4:11:18 PM by: RUSSELL WELLS
 O:\2008\OK08\08\08\08-08-C-Operat\OperatPlan.dwg

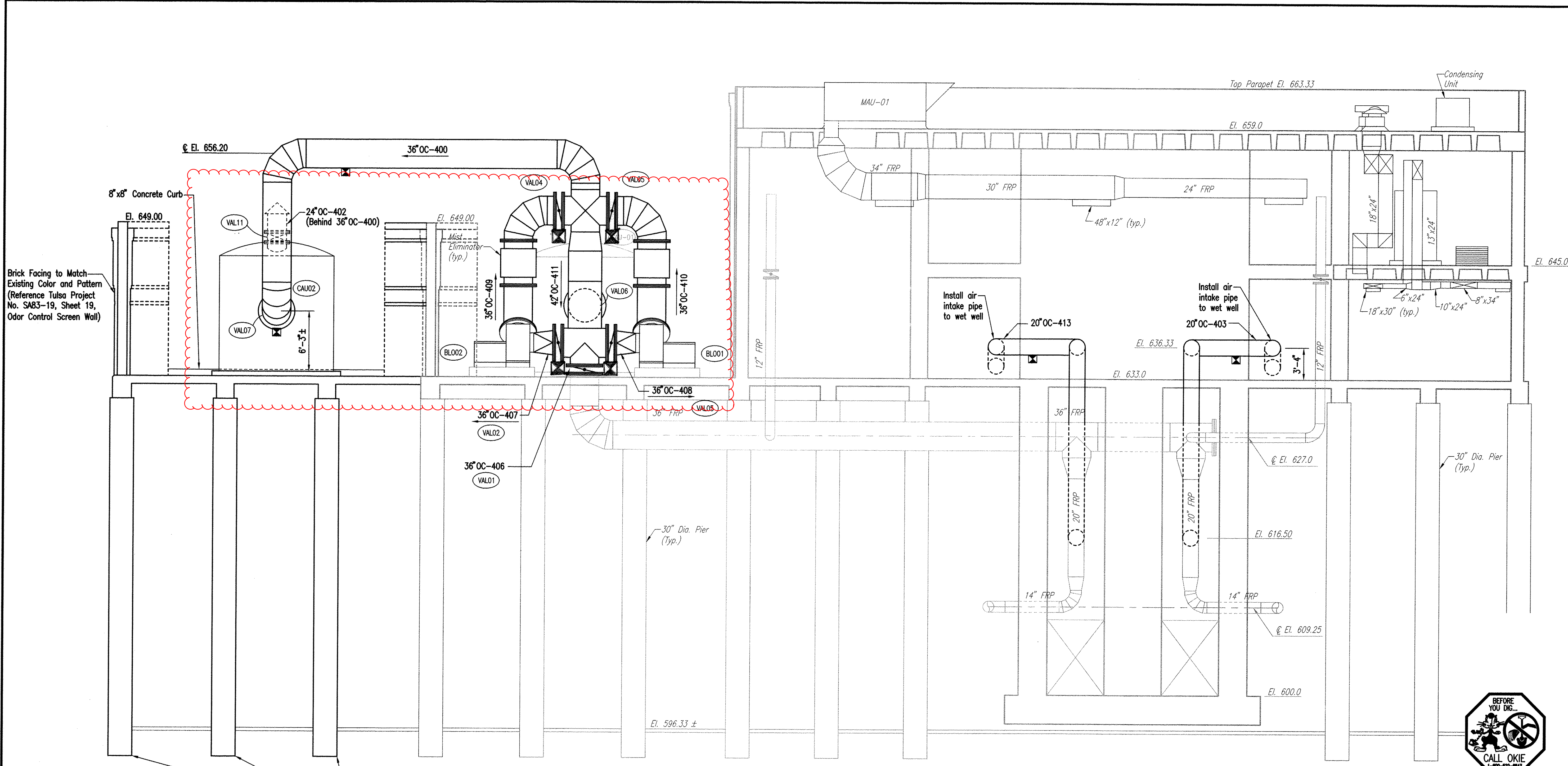

Brick Facing to Match Existing Color and Pattern (Reference Tulsa Project No. SA83-19, Sheet 19, Odor Control Screen Wall)

1 SECTION
C7.8 SCALE: 3/16" = 1'-0"
0 4 8



EXISTING UNDERGROUND LINES HAVE BEEN SHOWN TO THE EXTENT KNOWN AND PLANS HAVE BEEN SENT TO THE AFFECTED UTILITY OWNERS FOR VERIFICATION OF EXISTING LINES. BEFORE YOU DIG, CALL OKIE: 1-800-522-6543.

RECORD DRAWING

THESE RECORD DRAWINGS HAVE BEEN PREPARED BASED ON INFORMATION PROVIDED BY OTHERS. THE ENGINEER HAS NOT VERIFIED THE ACCURACY OF THIS INFORMATION AND SHALL NOT BE RESPONSIBLE FOR ANY ERRORS OR OMISSIONS WHICH MAY BE INCORPORATED HEREIN AS A RESULT.

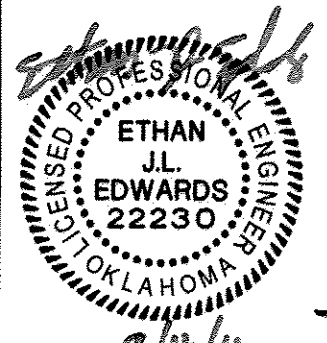

8/12/11 TB 8/22/11
July 8, 2013

CHERRY CREEK LIFT STATION IMPROVEMENT SECTION
CHERRY CREEK LIFT STATION IMPROVEMENTS
PROJECT NUMBER: SA 05-01
CITY OF TULSA, OKLAHOMA
PUBLIC WORKS DEPARTMENT
ENGINEERING SERVICES DIVISION

PLANS AND ESTIMATES PREPARED BY:	Professional Engineering Consultants, P.A. CHERRY CREEK BUILDING - 4150 SOUTH 100 TH EAST AVENUE, SUITE 401 TULSA, OKLAHOMA 74146-9318 PHONE: 918-486-5400 FAX: 918-486-5400	APPROVED:
PLAN SCALE:	DRAWN	APPROVED:
DESIGNED		
SURVEY		
PROFILE SCALE:	FIELD MGR. <i>7/28/11</i>	APPROVED:
HORIZONTAL:	SECT. MGR. <i>1/26/11</i>	
	PROJ. MGR. <i>8/2/11</i>	
VERTICAL	RECOMMENDED:	PUBLIC WORKS DIRECTOR
	DEPUTY DIRECTOR	
FILE:	DRAWING: C4.2	DATE: AUGUST, 2011
ATLAS PAGE NO:		SHEET 12 OF 22 SHEETS

NOTE TO CONTRACTOR:

- CONTRACTOR SHALL REMOVE ALL EQUIPMENT AND THAT PORTION OF STRUCTURES DESIGNATED TO BE DEMOLISHED UNLESS NOTED OTHERWISE. DEMOLITION PLANS PROVIDED REFLECT BEST AVAILABLE INFORMATION. CONTRACTOR SHALL COMPLETE DEMOLITION WORK ON STRUCTURES AND EQUIPMENT AS THEY EXIST FOR THE UNIT PRICE BID FOR PROJECT IMPROVEMENTS. ALL EQUIPMENT REMOVED SHALL BE DISPOSED OF OFF-SITE UNLESS DIRECTED OTHERWISE.
- CONTRACTOR TO FIELD VERIFY DIMENSIONS AND LOCATIONS OF EXISTING EQUIPMENT. CONTRACTOR TO ADJUST EQUIPMENT AND PIPING AS REQUIRED TO FIT EXISTING CONDITIONS AT NO ADDITIONAL COST TO THE OWNER.
- REMOVE AND DISPOSE OF CARBON FROM CAU-01.
- PROVIDE NEW CARBON MEDIA FOR CAU-01 AND CAU-02.

☒ Indicates where piping or equipment needs to be adequately supported. See Structural sheets for pipe support.

Sheet 08-16-2011 9:40:49 AM by: EMC
Plot Scale: 11 06-16-2011 4:12:24 PM by: RUSSELL WELLS
C:\2008\OKS06\008\08608-008-C-ColorControl-Sections

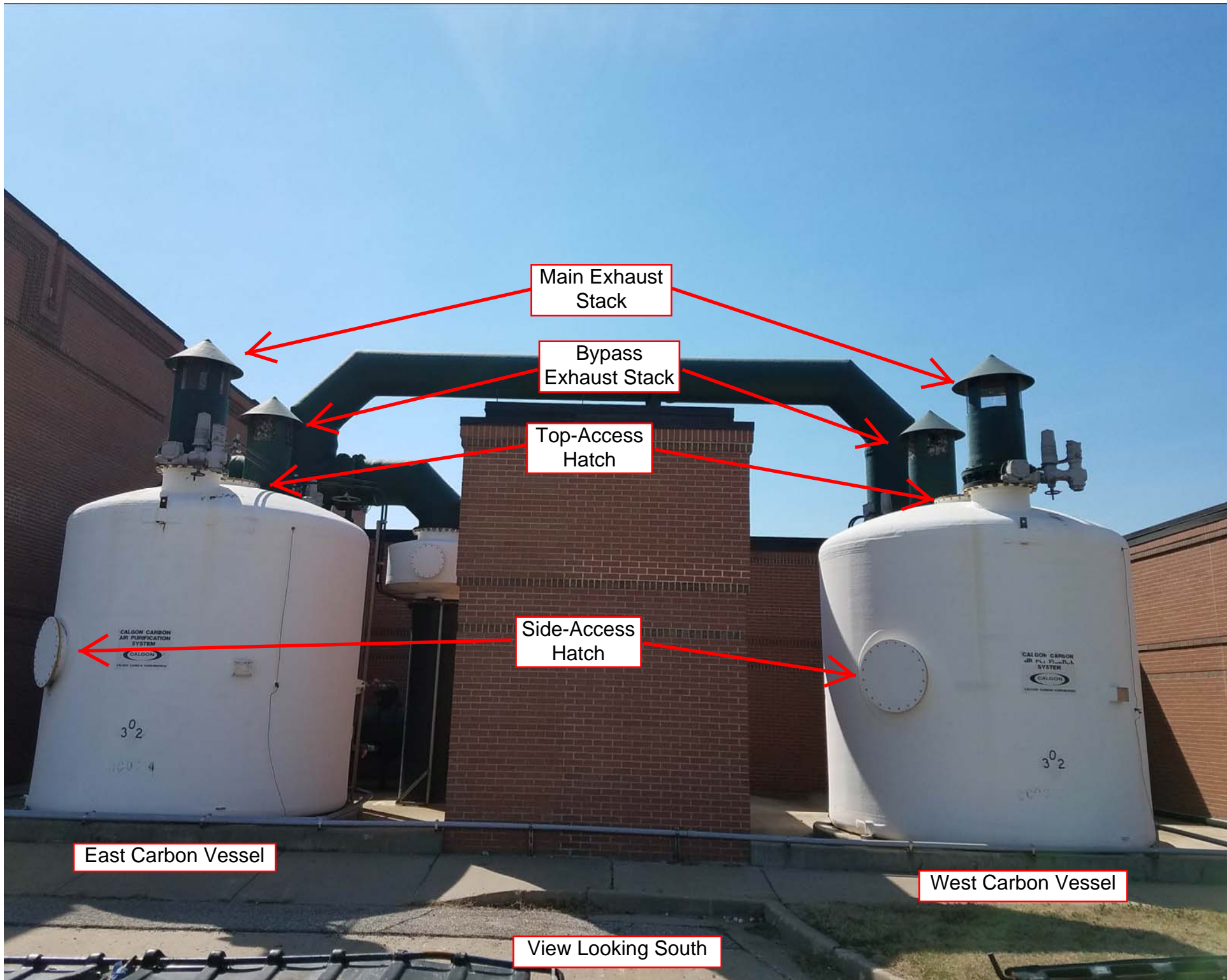

Main Exhaust Stack

Bypass Exhaust Stack

Top-Access Hatch

Side-Access Hatch

East Carbon Vessel

West Carbon Vessel

View Looking South

During normal operation, the bypass exhaust stack is shut.

During normal operation, the main exhaust stack is open.

During normal operation, foul air is forced down through the carbon media. Then it is directed up through the internal pipe and out the main exhaust stack.

An internal pipe is open below the bed of carbon and connects to the main exhaust stack.

Single bed of carbon is 12 feet in diameter and about 3 feet deep.

East Carbon Vessel

West Carbon Vessel

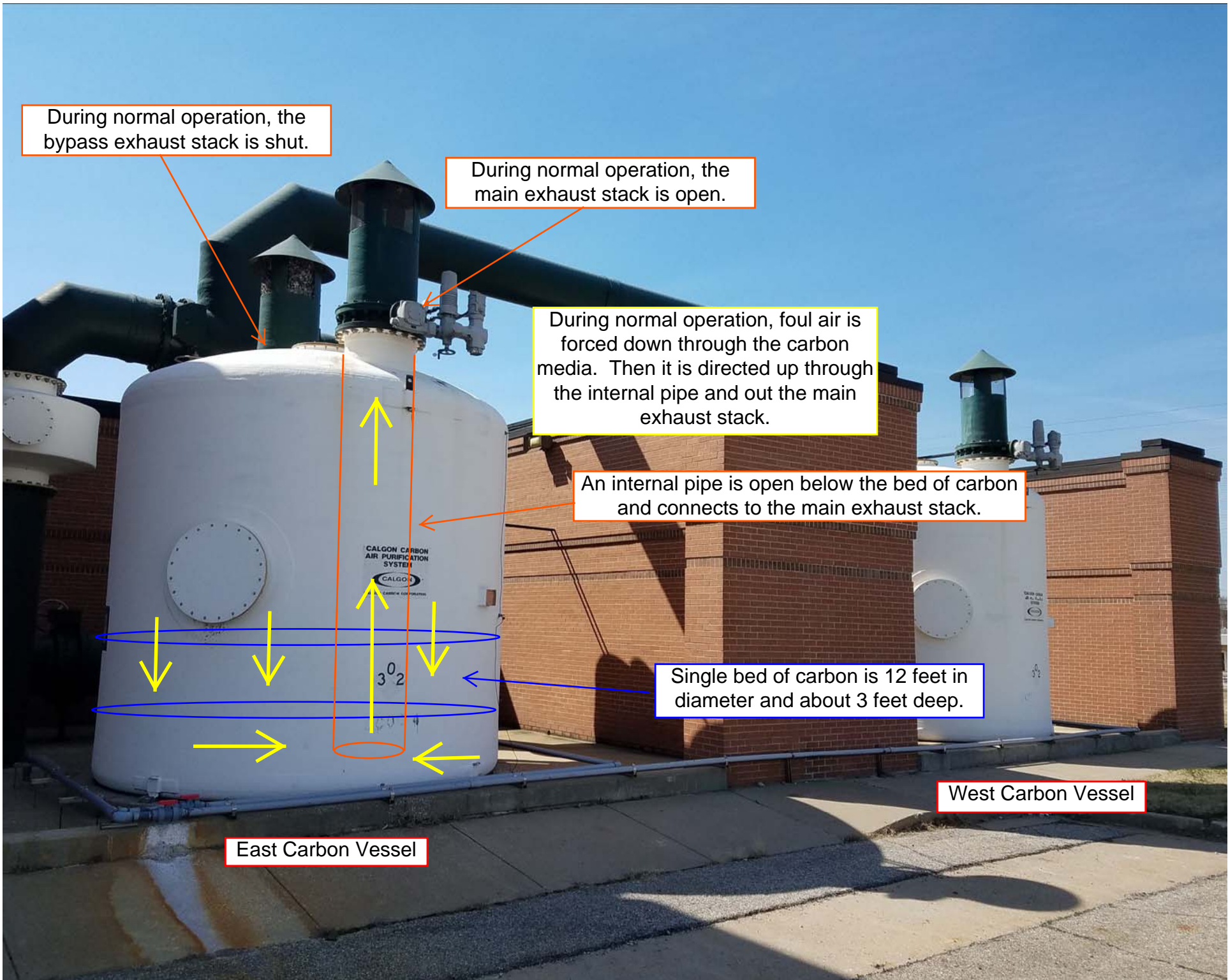

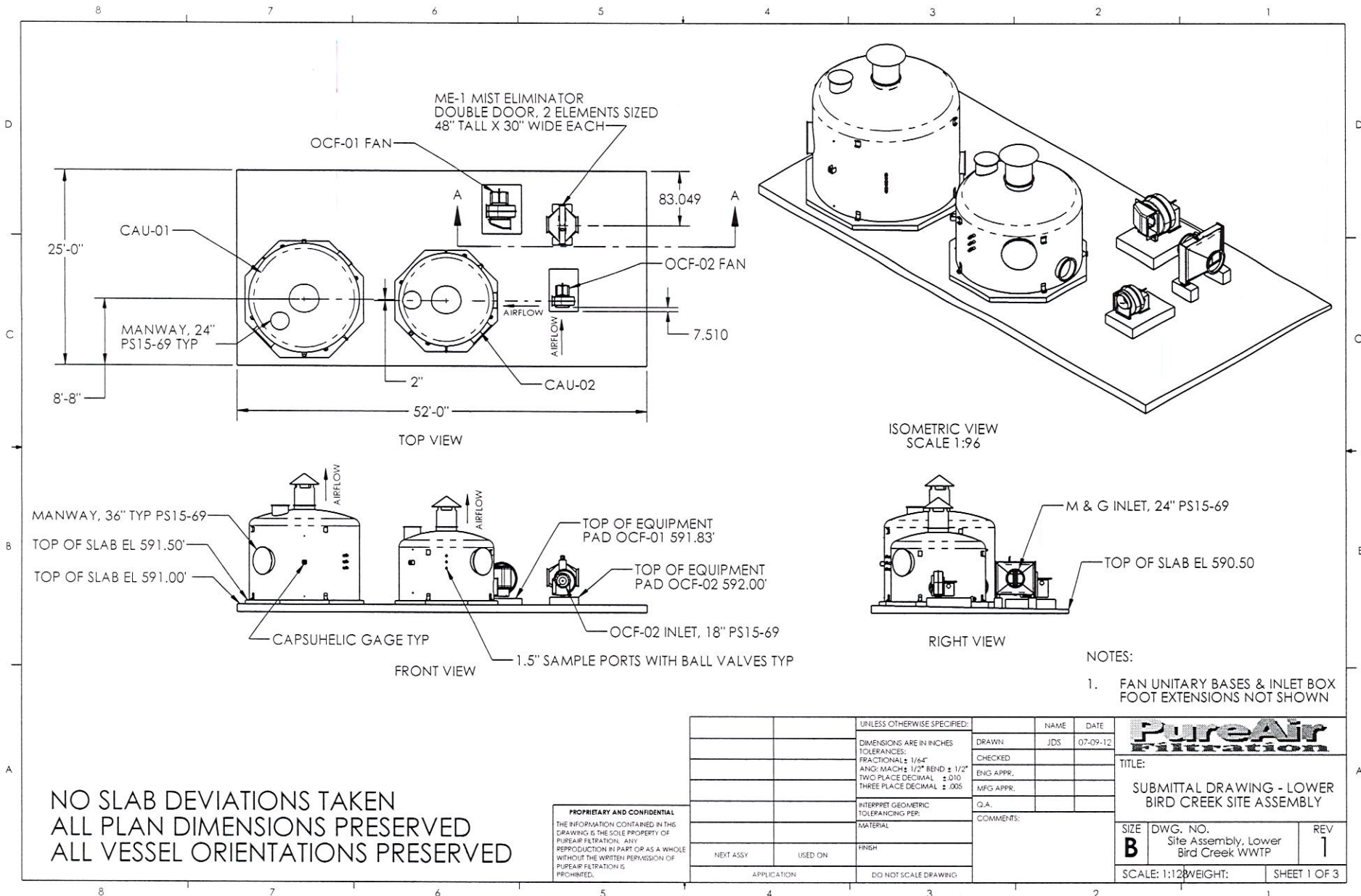

NO SLAB DEVIATIONS TAKEN
ALL PLAN DIMENSIONS PRESERVED
ALL VESSEL ORIENTATIONS PRESERVED

PROPRIETARY AND CONFIDENTIAL
THE INFORMATION CONTAINED IN THIS DRAWING IS THE SOLE PROPERTY OF PUREAIR FILTRATION. ANY REPRODUCTION IN PART OR AS A WHOLE WITHOUT THE WRITTEN PERMISSION OF PUREAIR FILTRATION IS PROHIBITED.

		UNLESS OTHERWISE SPECIFIED:	NAME	DATE
		DIMENSIONS ARE IN INCHES	JDS	07-09-12
		TOLERANCES:		
		FRACTIONAL ± 1/64"	CHECKED	
		ANG: MACH ± 1/2" BEND ± 1/2"	ENG APPR.	
		TWO PLACE DECIMAL ± 0.10	MFG APPR.	
		THREE PLACE DECIMAL ± 0.005	Q.A.	
		INTERPRET GEOMETRIC TOLERANCING PER:	COMMENTS:	
		MATERIAL		
		FINISH		
NEXT ASSY	USED ON	APPLICATION		
		DO NOT SCALE DRAWING		

PureAir
Filtration

TITLE:
SUBMITTAL DRAWING - LOWER BIRD CREEK SITE ASSEMBLY

SIZE	DWG. NO.	REV
B	Site Assembly, Lower Bird Creek WWTP	1
SCALE: 1:12	WEIGHT:	SHEET 1 OF 3

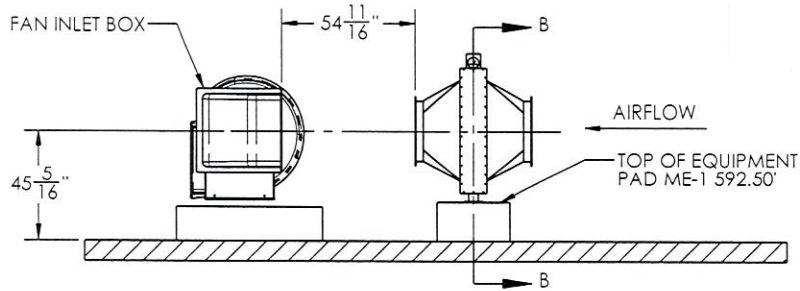

SECTION A-A
SCALE 1 : 48

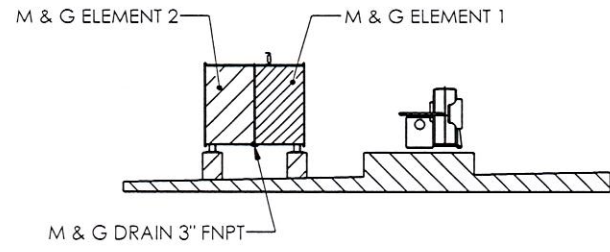

SECTION B-B
SCALE 1 : 72

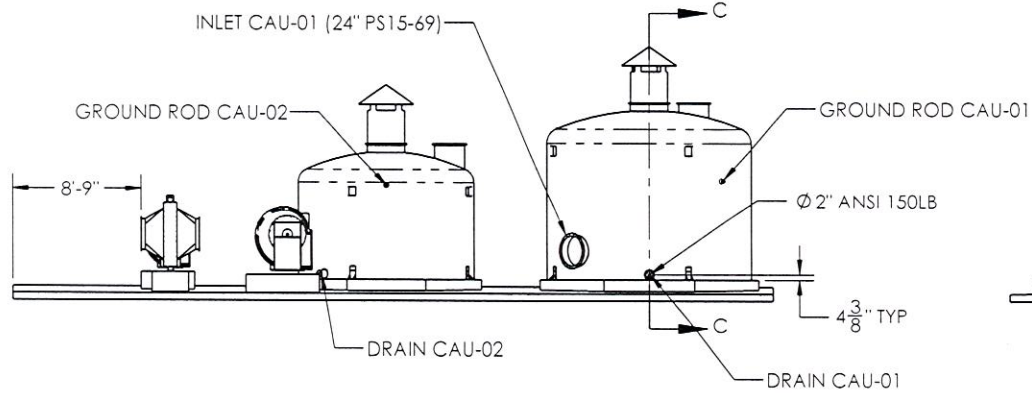

BACK VIEW

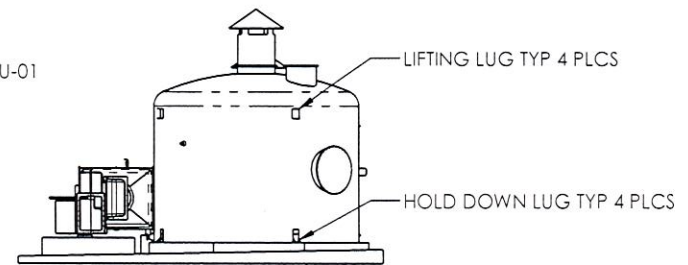

AUX PROJECTED VIEW
(LEFT VIEW)

PROPRIETARY AND CONFIDENTIAL
THE INFORMATION CONTAINED IN THIS DRAWING IS THE SOLE PROPERTY OF PUREAIR FILTRATION. ANY REPRODUCTION IN PART OR AS A WHOLE WITHOUT THE WRITTEN PERMISSION OF PUREAIR FILTRATION IS PROHIBITED.

		UNLESS OTHERWISE SPECIFIED:	NAME	DATE
		DIMENSIONS ARE IN INCHES	JDS	07-09-12
		TOLERANCES:	DRAWN	
		FRACTIONAL: 1/64"	CHECKED	
		ANG: MACH: 1/2" BEND ± 1/2"	ENG APPR.	
		TWO PLACE DECIMAL: ± 0.10	MFG APPR.	
		THREE PLACE DECIMAL: ± 0.005	Q.A.	
		INTERPRET GEOMETRIC TOLERANCING PER:	COMMENTS:	
		MATERIAL		
		FINISH		
NEXT ASSY	USED ON			
APPLICATION		DO NOT SCALE DRAWING		

PureAir Filtration

TITLE:
SUBMITTAL DRAWING - LOWER BIRD CREEK SITE ASSEMBLY

SIZE	DWG. NO.	REV
B	Site Assembly, Lower Bird Creek WWTP	1

SCALE: 1:96 WEIGHT: SHEET 2 OF 3

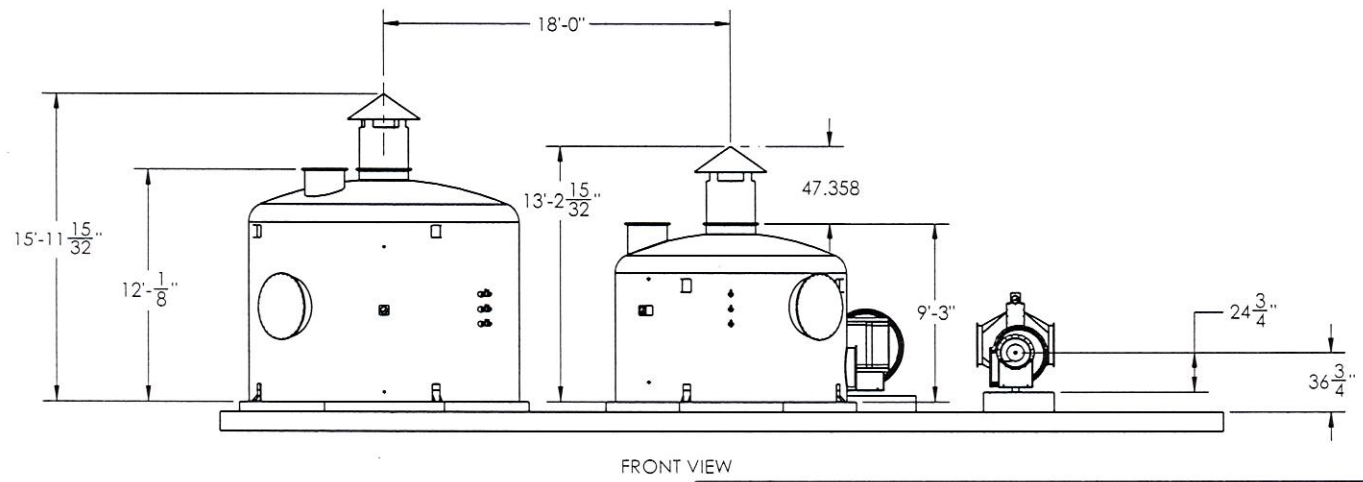
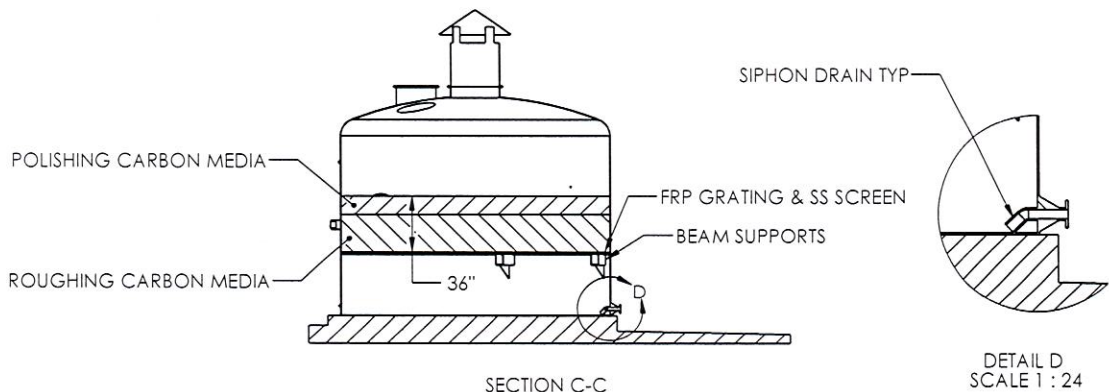

PROPRIETARY AND CONFIDENTIAL
 THE INFORMATION CONTAINED IN THIS DRAWING IS THE SOLE PROPERTY OF PUREAIR FILTRATION. ANY REPRODUCTION IN PART OR AS A WHOLE WITHOUT THE WRITTEN PERMISSION OF PUREAIR FILTRATION IS PROHIBITED.

UNLESS OTHERWISE SPECIFIED:		NAME	DATE
DIMENSIONS ARE IN INCHES TOLERANCES:		DRAWN	JDS 07-09-12
FRACTIONAL ± 1/64"		CHECKED	
ANG. MATCH ± 1/2" BEND ± 1/2"		ENG APPR.	
TWO PLACE DECIMAL ± 0.10		MFG APPR.	
THREE PLACE DECIMAL ± 0.05		G.A.	
INTERPRET GEOMETRIC TOLERANCING PER:		COMMENTS:	
MATERIAL:			
FINISH:			
NEXT ASSY	USED ON		
APPLICATION		DO NOT SCALE DRAWING	

PureAir Filtration

TITLE:
SUBMITTAL DRAWING - LOWER BIRD CREEK SITE ASSEMBLY

SIZE	DWG. NO.	REV
B	Site Assembly, Lower Bird Creek WWTP	1

SCALE: 1:72 WEIGHT: SHEET 3 OF 3

4

3

2

1

B

B

A

A

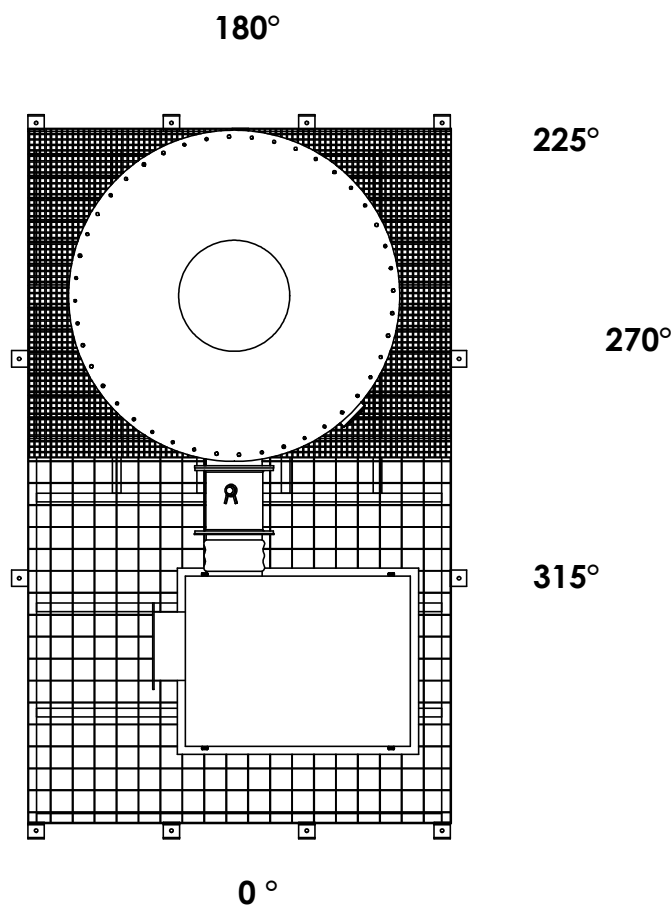

- NOTES: **UNLESS OTHERWISE STATED**
- DESIGN CODE: ASTM RTP-1
 - DIMENSIONAL TOLERANCES SHALL BE 1/8"
 - ALL FLANGES PER NBS PS 15-69
 - RESIN: HETRON 922 PREMIUM VINYL ESTER RESIN
 - ALL DIMENSIONS ARE APPROXIMATES.
 - BLOWER: 900 ACFM @ 4.38 IWC
 - MOTOR: 3 HP, 460/3/60 TEFC
 - FINAL SYSTEM MAY HAVE COSMETIC DIFFERENCES.
 - FINISH: RAL 7000

Part Name	Reference	Qty.	Location
VBS-4.5 TANK	A	1	---
VBS-4.5 TANK LID	B	1	---
EXHAUST STACK	C	1	---
10"Ø ID BUTTERFLY DAMPER	D	1	0°
FAN TRANSITION PIECE	E	1	0°
SOUND ENCLOSURE	F	1	0°
CONTROL PANEL STAND	G	1	315°
FRP SKID	H	1	---
MEDIA BED MONITORING ROD	I	1	315°
SS GROUNDING ROD	J	1	292.5°
ANCHOR LUG	K	4	45°, 135°, 225°, 315°
SOUND ENCLOSURE LID	L	1	0°
SOUND ENCLOSURE LOUVER	M	2	0°
FLEX CONNECTOR	N	1	0°
1" Ø PRESSURE TAP	O	2	315°
1"Ø SAMPLING PORT	P	3	270°
1"Ø DRAIN	Q	1	90°
1"Ø AIR SAMPLING PORT	R	1	180°
LIFTING LUG	S	4	22.5°, 112.5°, 202.5°, 292.5°

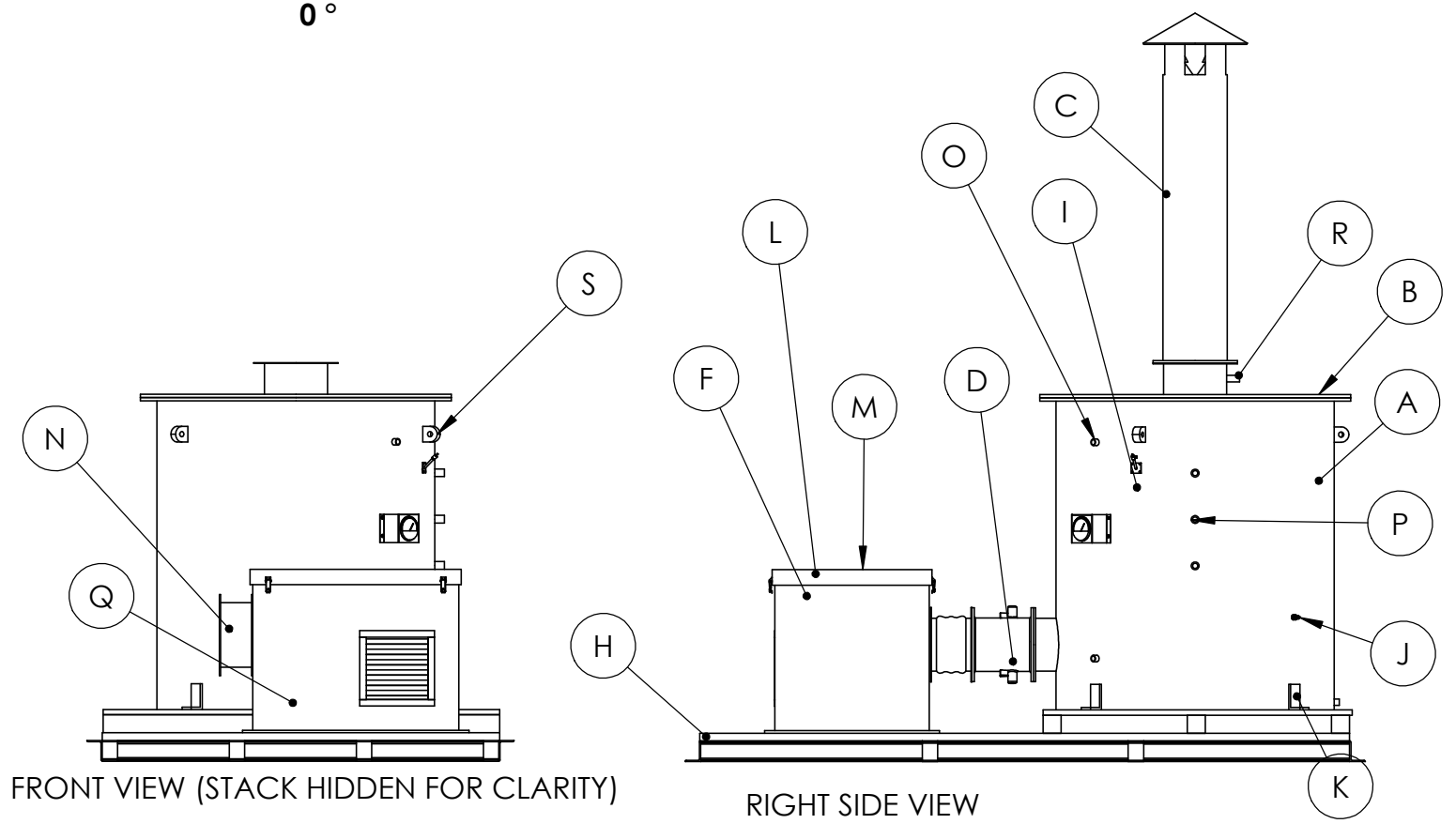

FRONT VIEW (STACK HIDDEN FOR CLARITY)

RIGHT SIDE VIEW



6050 Peachtree Parkway
Suite 240-187
Norcross, GA 30092
Phone: (678) 935-1431

DRAWN BY: DJL CHECKED BY: DATE: Wednesday, December 21, 2022 S.O. #: S2021-515 PROJECT NAME: WPC22-5-2102	COMPANY: PUREAIR FILTRATION CLIENT: DESCRIPTION: VBS-4.5 SYSTEM DRAWING DWG. NO: S2021-515-VBS-ASMB-FRP
PROPRIETARY AND CONFIDENTIAL THE INFORMATION CONTAINED IN THIS DRAWING IS THE SOLE PROPERTY OF PURE AIR FILTRATION. ANY REPRODUCTION IN PART OR AS A WHOLE WITHOUT THE WRITTEN PERMISSION OF PURE AIR FILTRATION IS PROHIBITED.	REV: 0 DO NOT SCALE DRAWING SHEET 1 OF 2

4

3

2

1

4

3

2

1

B

B

A

A

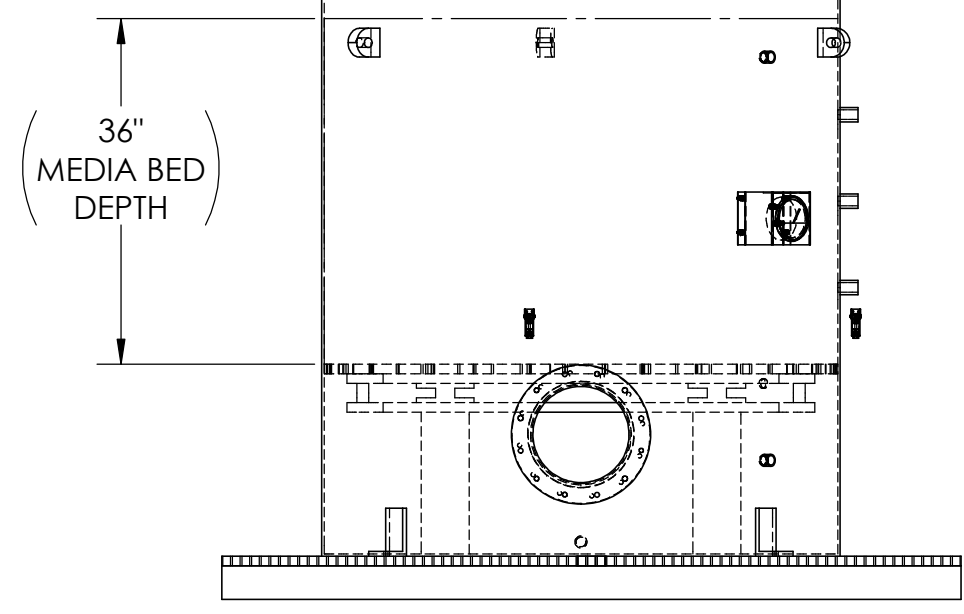
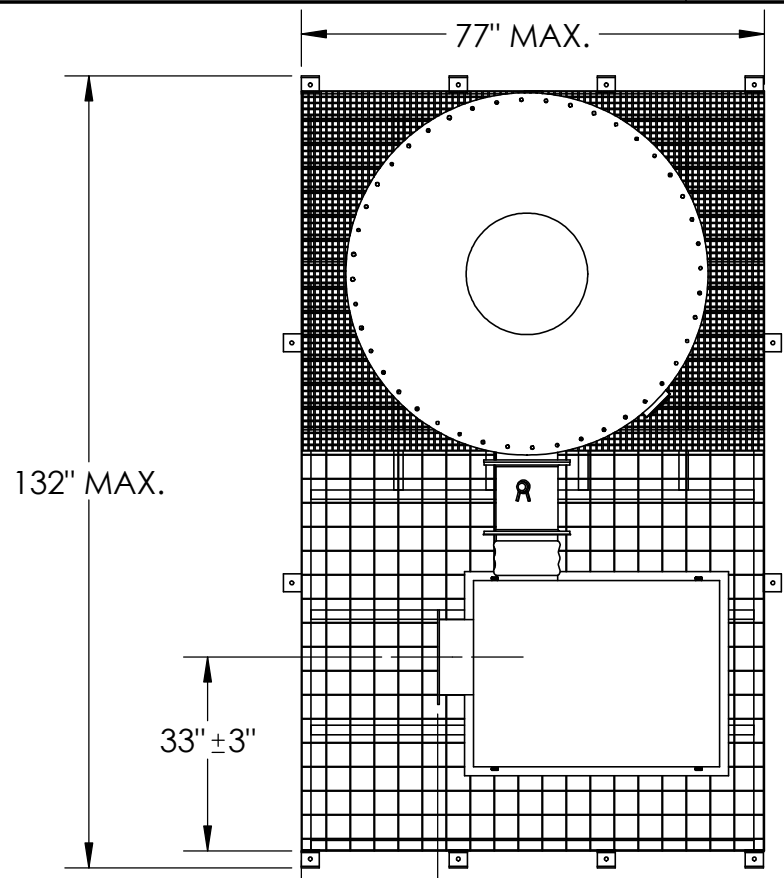

INTERNAL VIEW

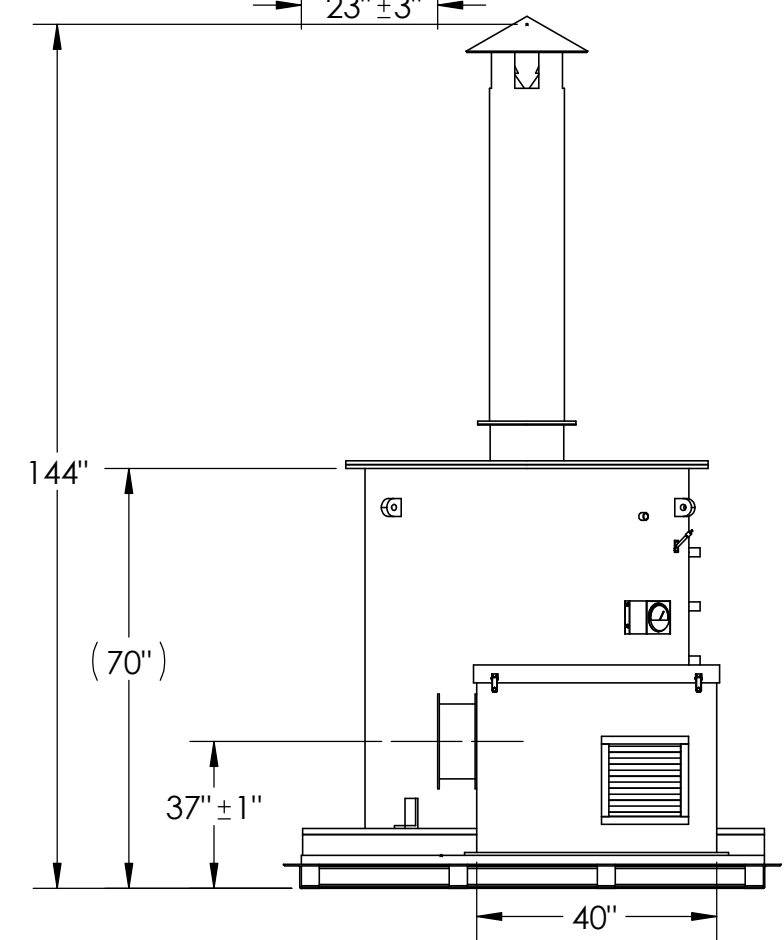

FRONT VIEW

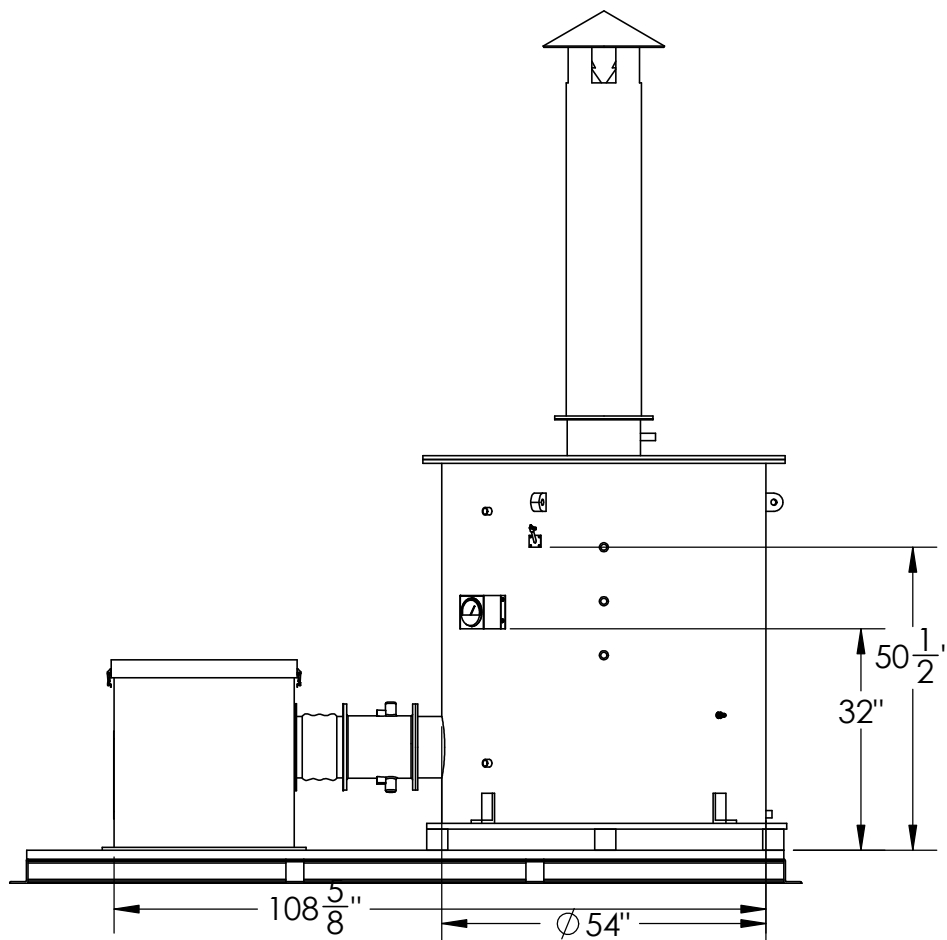

RIGHT SIDE VIEW

- NOTES: UNLESS OTHERWISE STATED
1. ALL DIMENSIONS ARE APPROXIMATE
 2. DIMENSIONS IN () ARE CRITICAL
 3. MATERIAL: PREMIUM VINYL ESTER RESIN (EITHER HETRON 922, DERAKANE 411, OR APPROVED EQUAL
 4. RATED AIR FLOW: 900 CFM
 5. PRESSURE RATING: 4.5 IWC
 6. ITEMS PROVIDED BUT NOT SHOWN:
 1. NEMA 4X FRP ENCLOSED CONTROL PANEL
 2. FRP BLOWER (IN SOUND ENCLOSURE)
 7. THICKNESS: .25"
 8. FLANGES AND TANK LID ARE PS15-69 STANDARD
 9. INLET HEIGHT TO BE DETERMINED WITH ACTUAL BLOWER DRAWING
 10. FINAL SYSTEM AMY HAVE COSMETIC DIFFERENCES
 11. SYSTEM FOLOW: RAL 7004 (SQUIRREL GRAY) UNLESS OTHERWISE SPECIFIED BY ENGINEER.
 12. NOT INCLUDED:
 1. MECHANICAL & ELECTRICAL INSTALLATION
 2. DUCTWORK
 3. ANCHOR BOLTS TO PAD
 4. MIST & GREASE ELIMINATOR

APPROXIMATE WEIGHTS:
 VESSEL (EMPTY): 800 LBS
 STACK: 80 LBS
 BLOWER W/ ENCLOSURE: APP. 400 LBS.
 MEDIA: 1431 LBS
 TOTAL (OPERATING): 2711 LBS.



6050 Peachtree Parkway
 Suite 240-187
 Norcross, GA 30092
 Phone: (678) 935-1431

DRAWN BY: DJL	COMPANY: PUREAIR FILTRATION
CHECKED BY:	CLIENT:
DATE: Wednesday, December 21, 2022	DESCRIPTION: DIMENSIONED SYSTEM ASSEMBLY
S.O. #: S2021-515	
PROJECT NAME: WPC 22-2102	
PROPRIETARY AND CONFIDENTIAL THE INFORMATION CONTAINED IN THIS DRAWING IS THE SOLE PROPERTY OF PURE AIR FILTRATION. ANY REPRODUCTION IN PART OR AS A WHOLE WITHOUT THE WRITTEN PERMISSION OF PURE AIR FILTRATION IS PROHIBITED.	DWG. NO: S2021-515-SYS-ASMB-FRP
REV: 0	DO NOT SCALE DRAWING
	SHEET 2 OF 2

4

3

2

1

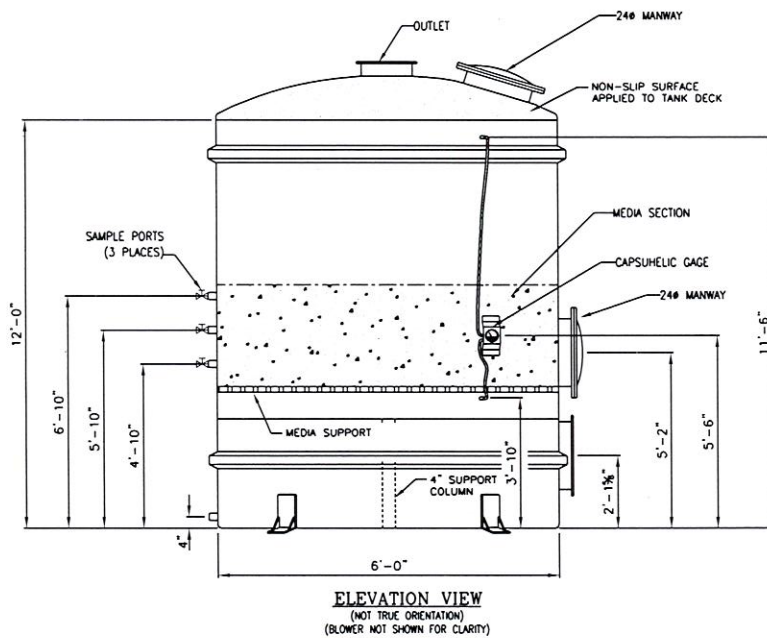
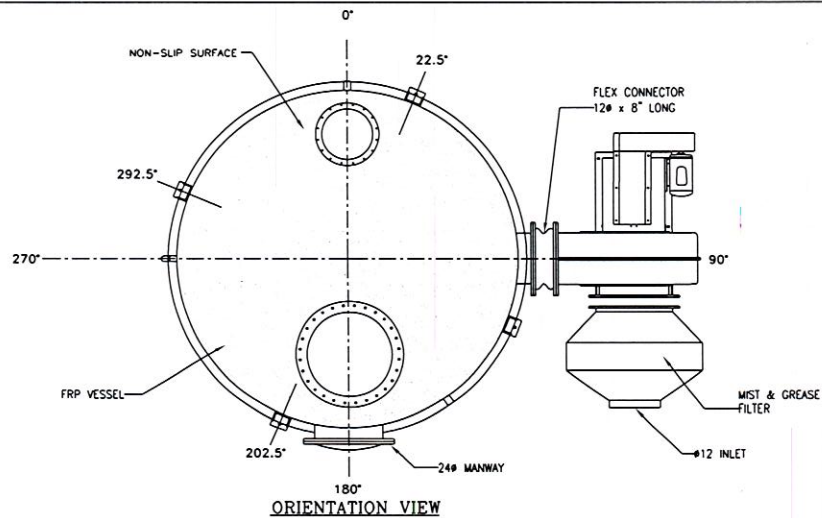

NOTES

CONSTRUCTION

NOTES:

1. THE VESSEL IS CONSTRUCTED OF A FIBERGLASS REINFORCED PLASTIC (FRP).
2. ALL FASTENERS ARE 316 STAINLESS STEEL.
3. EQUIPPED WITH FRP BLOWER MOUNTED WITH MOTOR AND SHEAVES. THE BLOWER SHALL BE V-BELT DRIVEN.
4. MEDIA BED DEPTH: 3'
5. MIST AND GREASE FILTER SHOWN (OPTIONAL ACCESSORY)

UNIT OPTIONS

NOTES:

1. EXHAUST STACK

MISCELLANEOUS

**PureAir
Filtration**

6050 Peachtree Pkwy
Suite 240-187
Atlanta, GA 30092
(678) 935-1431

PROJECT:

MODEL: VBS-6-MG

DRAWING: 1

SCALE: N.T.S. DRAWN BY: JPB REVISION: - DATE: APRIL 2, 2013

PROPRIETARY INFORMATION

THIS DOCUMENT CONTAINS PUREAIR FILTRATION LLC. PROPRIETARY AND CONFIDENTIAL INFORMATION. IT IS LOANED FOR LIMITED PURPOSES ONLY AND REMAINS THE PROPERTY OF PUREAIR FILTRATION LLC. IT MAY NOT BE REPRODUCED IN WHOLE OR PART OR DISCLOSED TO THIRD PARTIES WITHOUT THE PRIOR WRITTEN CONSENT OF PUREAIR FILTRATION LLC. THE DOCUMENT IS TO BE RETURNED TO PUREAIR FILTRATION LLC. UPON REQUEST AND IN ALL EVENTS UPON COMPLETION OF THE USE FOR WHICH IT WAS LOANED.