



# City of Tulsa

## SPECIAL EVENT PERMIT APPLICATION

### Summary of Event

---

Name of Event: Phoenix District Better BlockDate(s) of Event: Sept. 5 - Dec. 12, 2023Location Address: Start: 1124 E 36th St N  
End: 1124 E 36th St NCouncil District(s): 1Event Description: We are creating a space for an ongoing, 3-month activation primarily for a market. It may host business classes and perhaps small performances. When not activated, it will have some seating.Event Category: Farmers/Outdoor MarketEvent Includes: Amplified Sound, Tent/Canopy, Generator/Electricity, Live Entertainment, Food Sales, Merchandise Sales, No Parking Signage, Private PropertyAnticipated Attendance: Total: 2800Per Day: 100Anticipated Participants: Total: 2800Per Day: 100Number of Events for Monthly Event: No

### Host Organization, Applicant and Professional Event Organizer Information

---

Host Organization: Better Block FoundationWebsite: <https://www.betterblock.org/>Chief Officer of Host Organization: Krista NightengaleEmail and Phone: krista@betterblock.org 405-615-2623Applicant Name: Azael AlvarezEmail and Phone: azael@betterblock.org 469-426-5094

Professional Event Organizer:

Email and Phone:

On-site Contact: Azael AlvarezMobile: 469-426-5094Billing Contact: Better Block FoundationPhone: 469-426-5094Billing Address: 1723 S Ewing AVE  
Dallas, TX 75216

## ***Event Timeline and Lane/Street Closure Information***

---

**Event Setup:** Date: 09/05/2023 Time: 9 am  
Street Closure for Event Setup: Date: Time:  
Street(s) to be Closed for Event Setup: None

**Event Start:** Date: 09/08/2023 Time: 6 pm  
Street Closure for Event Start: Date: Time:  
Street(s) to be Closed for Event Start: None  
Run, Walk, Parade Start Time: N/A  
Daily Event Hours: Weekdays: 6 pm - 10 pm  
Weekends: 11 am - 3 pm  
"subject to change"

**Event End:** Date: 12/12/2023 Time: 9 am  
Street Reopens after Event End: Date: Time:

**Event Teardown:** Date: 12/12/2023 Time: 9 am  
Street Reopens after Event Teardown: Date: Time:

## ***Secondary Permits Required***

---

Beer Sales, Alcohol Sales: Not Applicable  
Number of Food Vendors: 5  
Number of Food Trucks: 5  
Food Cooked on-site: Yes Fuel(s) to be used: Gas  
Number of Item Vendors: 12 Number of Service Vendors: 12  
Number & Sizes of Tents: (12) 10' x 10' tents Provider and Phone: Vendor Owned  
Number of Inflatables: No 0 Provider and Phone: NA  
Number of Amusement Rides: No 0 Provider and Phone: NA  
Use of fireworks, rockets, lasers, or other pyrotechnics: No  
Provider and Phone: N/A

## **Security, Medical, Traffic Control, Crowd Management and Parking Plans**

Security and/or Police: No Contact, Email and Phone: See Security Plan

Medical and/or First Aid Services: Yes Contact, Email and Phone: Tulsa Fire Department (918) 596-9200, Robert Brown, robertbrown@cityoftulsa.org  
Friday, September 8th, 6pm-10pm; Saturday, September 9th, 11 am-3 pm  
First Aid Station on-site. See Emergency Plan

Traffic Control Barricade Company: No Contact, Email and Phone: N/A

Equipment Setup: Date: \_\_\_\_\_ Time: \_\_\_\_\_ Equipment Pickup: Date: \_\_\_\_\_ Time: \_\_\_\_\_

Crowd Management Fencing Company: No Contact, Email and Phone: N/A

Equipment Setup: Date: \_\_\_\_\_ Time: \_\_\_\_\_ Equipment Pickup: Date: \_\_\_\_\_ Time: \_\_\_\_\_

Parking Type: ADA parking available, Paved Lot

Transportation Service: Shuttle Service

Transportation Service: Contact, Email and Phone: Tulsa Housing Authority/Comanche Park is looking into providing transportation to relocated residents.

## **Sponsor and Other Event Information**

Event Sponsor(s): Phoenix District Tulsa, Vibrant Neighborhood Partnership, INCOG, George Kaiser Family Foundation, and Crossover Community Center

Park: No Name of Park and Location: NA

Drone: Yes

Portable Toilets: Yes Provider and Phone: At Your Service Rentals (918) 272-0568

Total Number of Portable Toilets: 2 Number of ADA Accessible Portable Toilets: 1

Equipment Setup: Date: 09/05/2023 Time: 9 am

Equipment Pickup: Date: 09/11/2023 Time: 9 am

Other Event Information: COT Permit Center Inspectors will inspect the structures per construction document. TFD Inspectors will inspect the tents. Applicant responsible for any electrical permits.

**Entertainment and Related Activities**

---

Number of Stages: 0

Number of Performers/Bands: TBD

Performer/Band name and music type: TBD

Sound Amplification: Yes

Start Time: 5 pm

Finish Time: 10 pm

Please describe the sound equipment that will be used for your event:

TBD

Sound checks conducted prior to the event: Yes

Start Time: 5 pm

Finish Time: 6 pm

Hot air balloons, fire lanterns or similar devices used at event: No Describe:

N/A

Use of any signs, banners, decorations, or special lighting used at event: Yes Describe:

TBD

**Mitigation of Impact**

---

Please describe your plan for cleanup and removal of recyclable goods, waste and garbage during and after your event: Volunteers and Better Block will be responsible of cleanup and removal of waste and garbage during and after the event.

Number of Trash Receptacles: 10

Number of Dumpsters: 1

Number of Recycling Containers: 5

Cleanup Service: No Provider and Phone: Volunteers and Better Block will be responsible of cleanup and removal

Presented Event Concept to:

Residents, Neighborhood Assn, Business Assn, Businesses, Places of Worship, Please see the attached list of entities.

If not presented, please explain:

NA

**Affidavit of Applicant**

---

I certify that the information contained in this Application is true and correct to the best of my knowledge and belief. That I have read, understand, and agree to abide by the rules and regulations governing this Event. I agree to comply with all requirements of the City, County and State, and any other regulatory entity related to this Event. I agree to pay and be financially responsible for any costs and fees that may be incurred by the City of Tulsa due to the Event. I further agree to indemnify and hold harmless the City of Tulsa, and all City of Tulsa officers, employees, agents, representatives, from any claims (including cost of defending such claims) or damages that may arise from activities related to the Event. I understand that a Permit does not excuse my failure to comply with orders of law enforcement personnel, firefighters, City Event personnel, or emergency workers, and does not provide immunity from civil claims of third parties that are based upon injuries sustained at, or in conjunction with this Event.

Initials:                     On File

---

**For City of Tulsa Special Events Committee Use Only**

Date received: 07/07/2023      Date routed: 08/14/2023      Date for review: 08/23/2023

Special Events Committee Recommendation: \_\_\_\_\_      Yes  No  \_\_\_\_\_

Date routed to Mayor: \_\_\_\_\_      Mayor's Recommendation: Yes  No  \_\_\_\_\_

Date routed to Council: \_\_\_\_\_      City Council Approval: Yes  No  \_\_\_\_\_

Date Permit Issued: \_\_\_\_\_      Comments: SEC meeting 08/16/2023. Fees paid  
08/14/2023.

---

---

# PROPOSED PARKING OPTIONS DURING ACTIVATIONS

- Legend**
- 📍 1124 E 36th St N
  - 🟡 Parking
  - 🔴 Site



Google Earth

📍 1124 E 36th St N

600 ft



# SITE PLAN: 1124 East 36th Street North, Tulsa, OK 74106

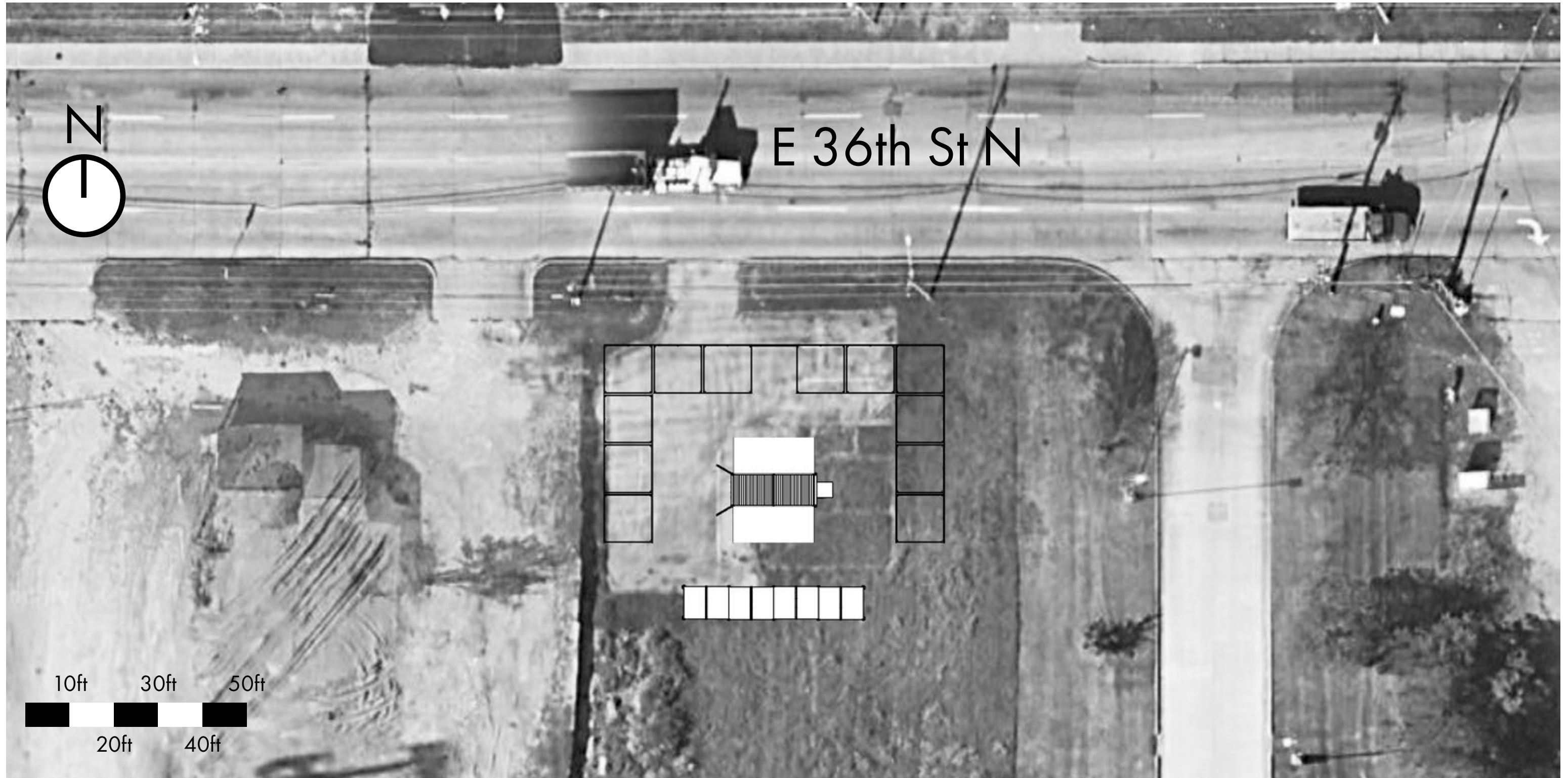

# PLAN WITH DIMENSIONS

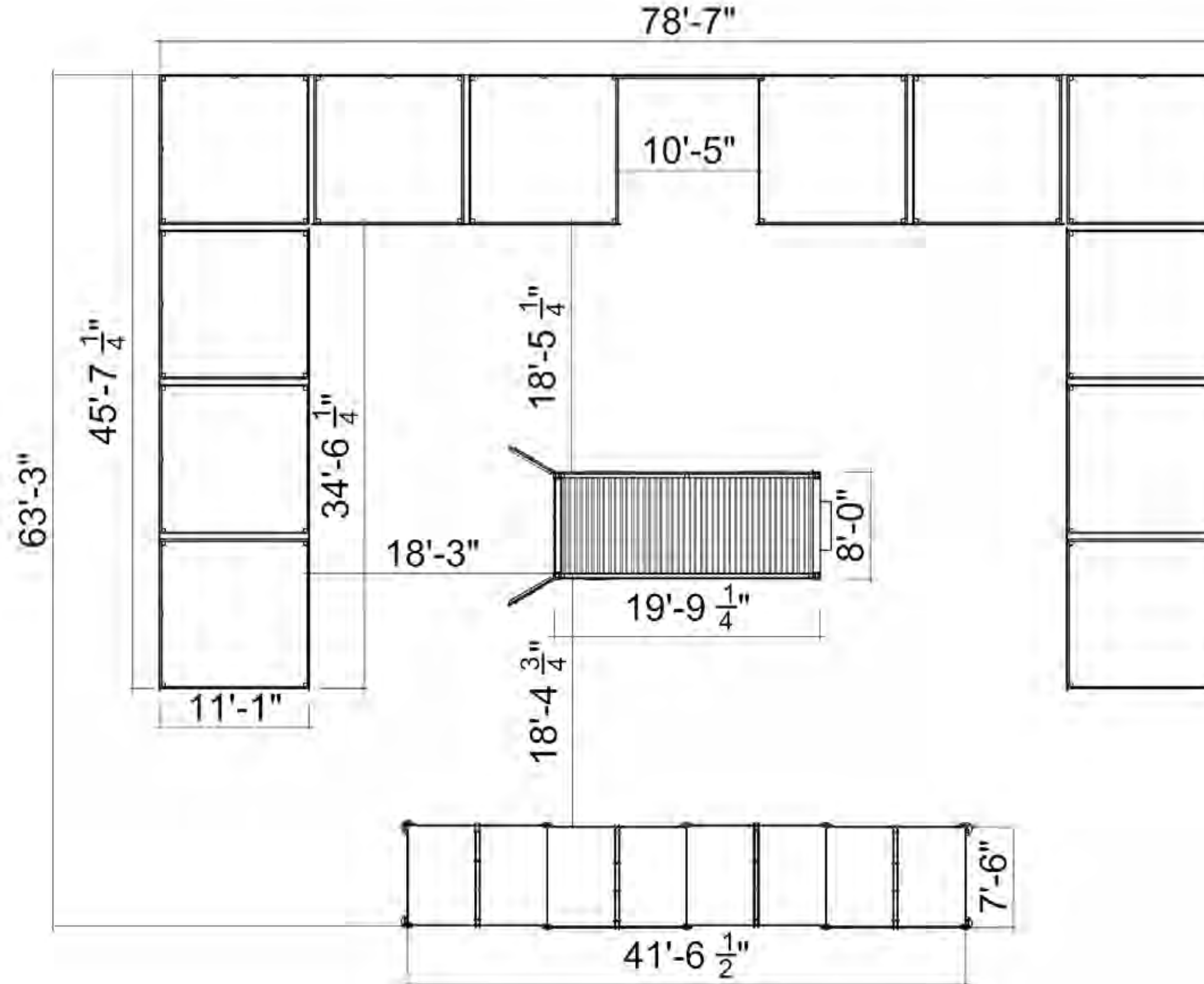



# INDIVIDUAL FACADE STALL

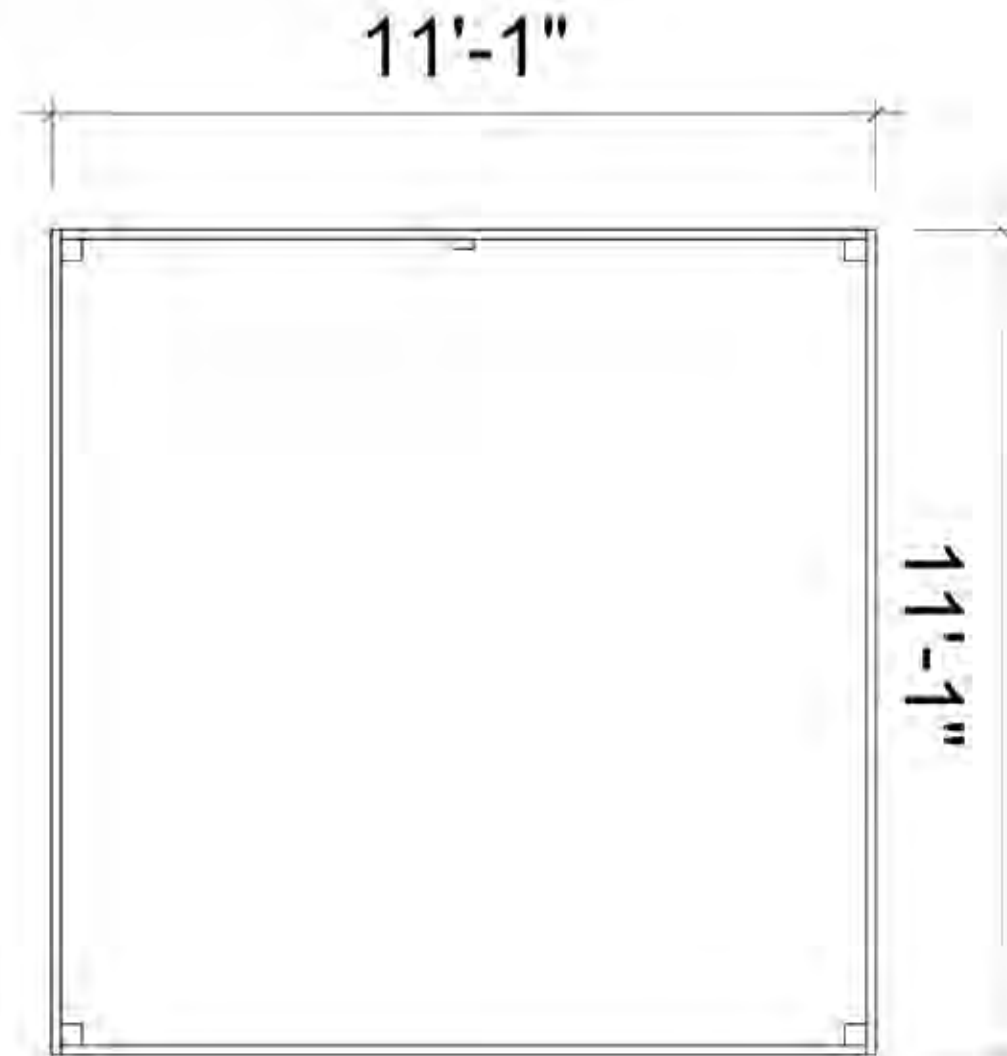

PLAN

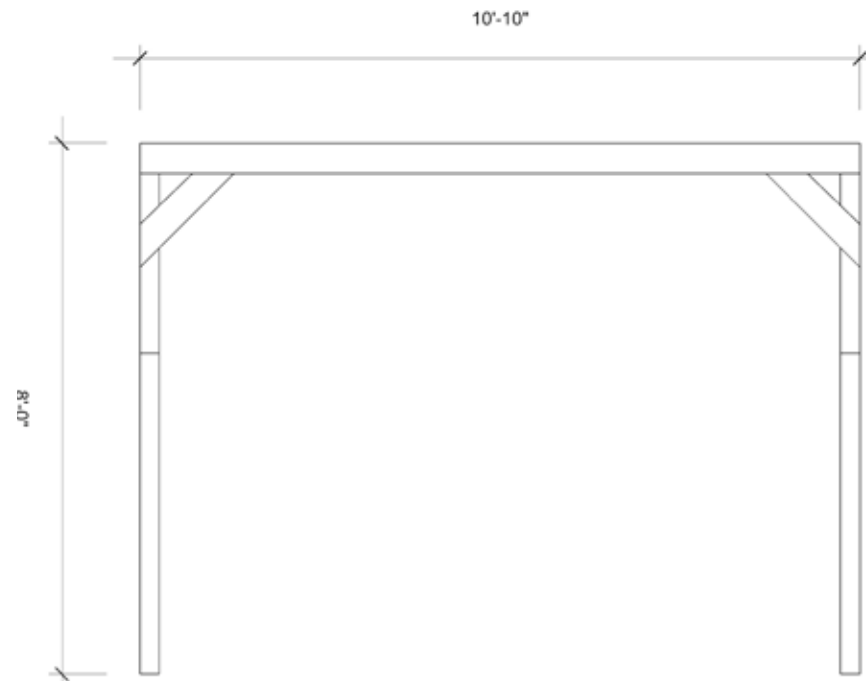

ELEVATION: INTERIOR OF SITE VIEW  
NO CUSTOM CNC PLYWOOD

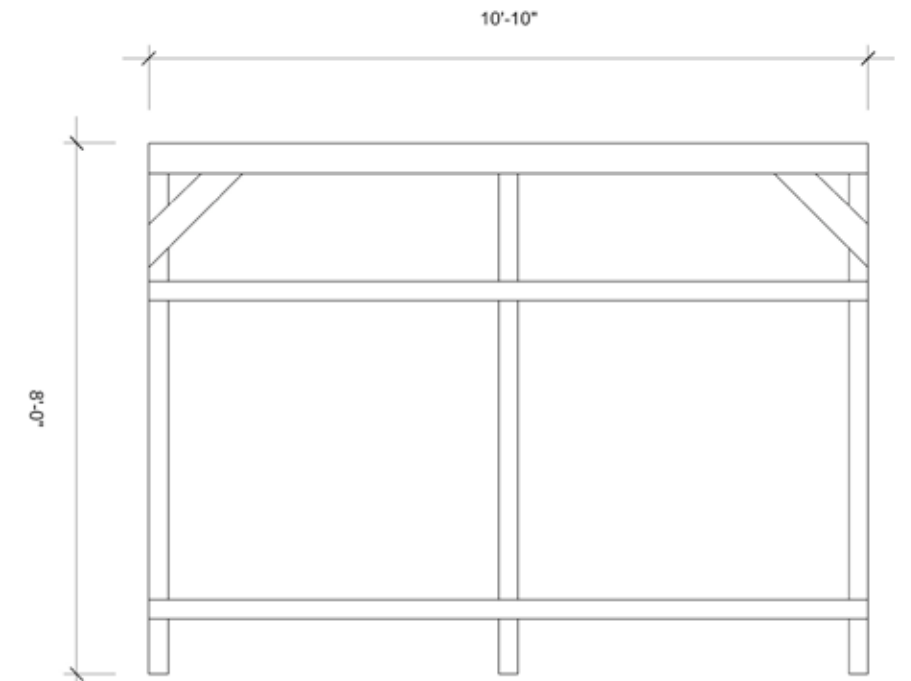

ELEVATION: EXTERIOR OF SITE VIEW  
NO CUSTOM CNC PLYWOOD

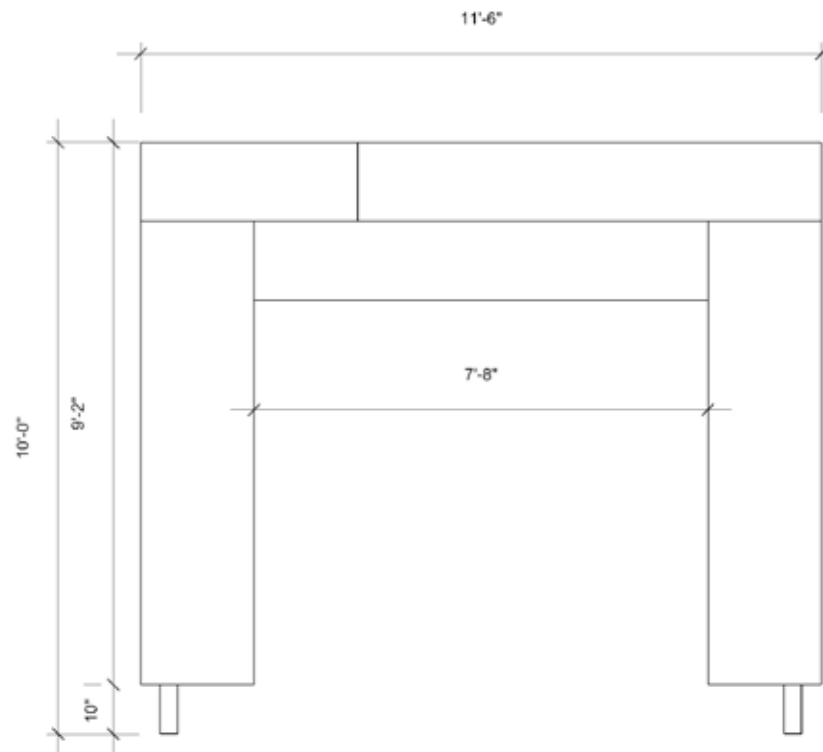

ELEVATION: INTERIOR OF SITE VIEW  
WITH CUSTOM CNC PLYWOOD

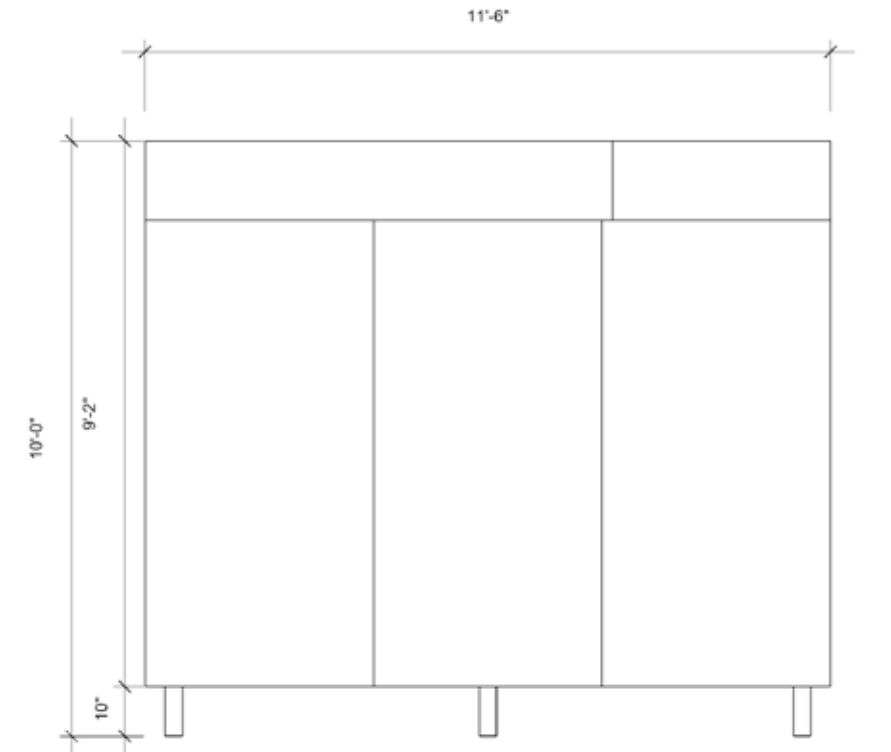

ELEVATION: EXTERIOR OF SITE VIEW  
WITH CUSTOM CNC PLYWOOD

# SHIPPING CONTAINER

INTERIOR  
PLAN

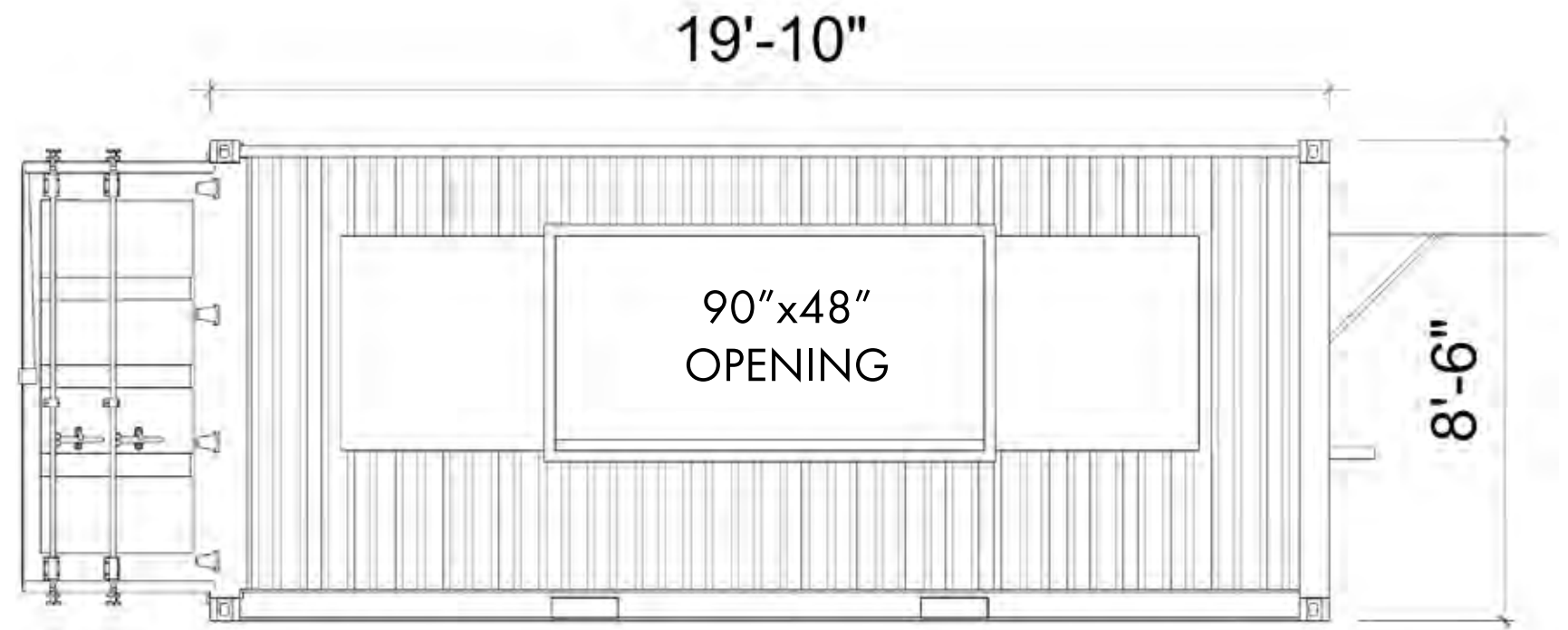
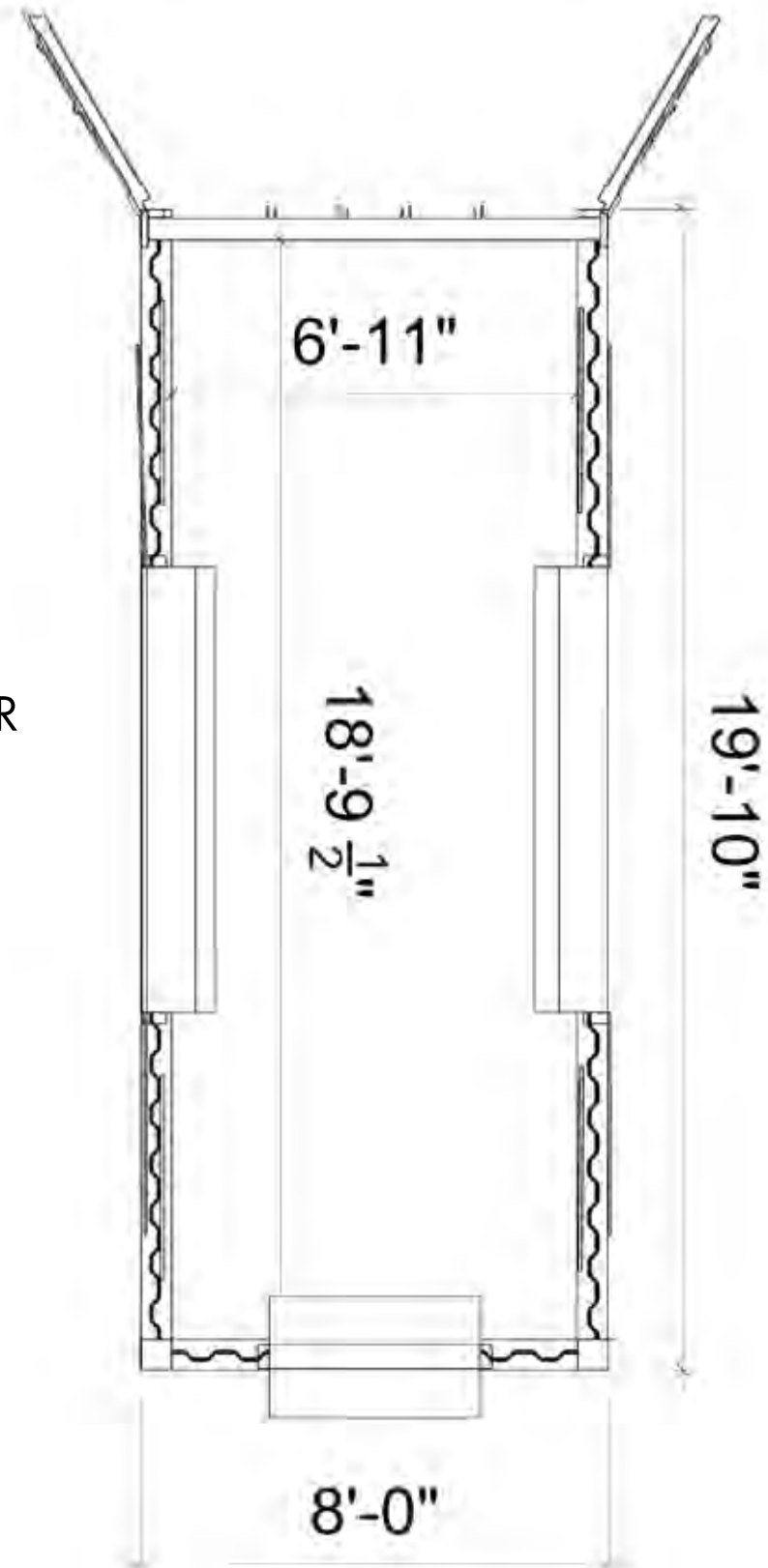

LONG SIDE ELEVATIONS

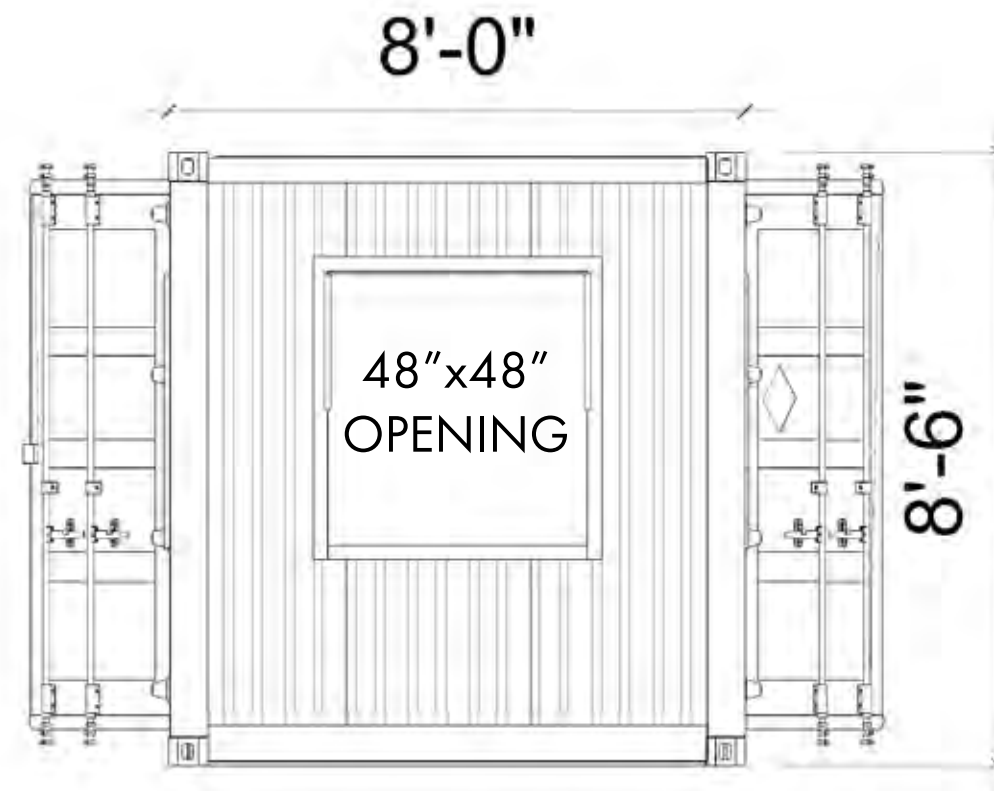

SHORT SIDE ELEVATION

# BIRD'S EYE VIEW



# BIRD'S EYE VIEW



# DESIGN

